

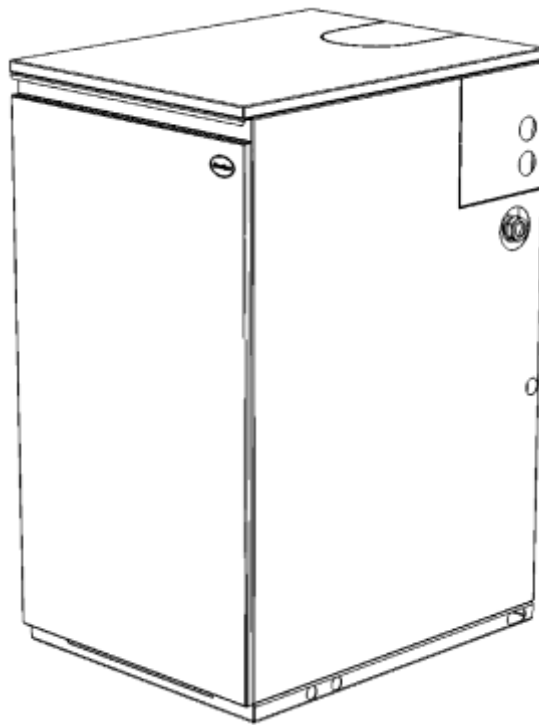

**Trianco EuroStar Band A
15/20, 20/26 & 29/36 kW
For Balanced or Conventional Flue**



**OPERATION, INSTALLATION,
COMMISSIONING & SERVICING
INSTRUCTIONS**

**Please read these instructions carefully before installing,
commissioning and using this appliance.**

To be retained by the householder.

HEALTH AND SAFETY

INFORMATION FOR THE USER, INSTALLER AND SERVICE ENGINEER

Under the Consumer Protection Act 1987 and the Health and Safety at Work Act 1974, it is a requirement to provide information on substances hazardous to health (COSHH Regulations 1998).

TR Engineering takes every reasonable care to ensure that its products are designed and constructed to meet these safety requirements when the products are properly installed and used. To fulfil the requirements, products are comprehensively tested and examined before despatch.

When working on the appliance, it is the responsibility of the user or engineer to ensure that personal protective clothing or equipment appropriate to parts that could be considered hazardous or harmful is worn.

This appliance may contain some of the items below:

Insulation and Seals

Glass rope, mineral wool, insulation pads, ceramic fibre and glass insulation.

When handling, avoid inhalation and contact with eyes. These may be harmful and cause irritation to the skin, eyes, nose or throat. Use disposable gloves, facemasks and eye protection.

After handling, wash hands and other exposed areas. When disposing of materials, limit dust and the risk of inhalation by using a water spray. Ensure materials are securely wrapped.

Seek urgent medical attention if inhaled or ingested. Exposure to eyes and skin should be followed by immediate cleansing of the affected areas and medical attention if necessary.

Glues, Sealants and Paints

The glues, sealants and paints used present no known hazards when the appliance is used in the manner for which it is intended.

Mineral Oils

The appliance is designed to run on 28 sec. Kerosene class C2. The effects of mineral oils on the skin will vary depending on the length of exposure.

Avoid any skin contact with oil or clothing contaminated with oil. Kerosene will remove the protective grease normally present on the surface of the skin, rendering it dry, liable to cracking and more prone to damage caused by cuts and abrasions. Seek immediate medical attention for any rash, wart or sore that develops on any part of the body.

Barrier cream that contains lanolin, such as Rosalex Antisolv is recommended together with a strict regime of personal cleaning.

Do not breathe oil vapours. Do not fire the burner in the open (i.e. out of the boiler), as a misfire will produce unburned oil vapours. Under no circumstances should mineral oils be taken internally.

CONTENTS	Page
How to use the boiler	4
Boiler & system control	4/5
Oil	5
Simple fault finding	5
Commissioning & servicing	5
After sales service	6
Installation notes	7
Technical information	8
Dimensions & connections	8
Technical specifications	9
Installation	10
Regulations / Health & Safety	10
Siting	10
Ventilation	10/11
System design	12
Electrical supply & wiring diagram	12
Condensing system	13
Oil	14
Storage & protection	14
Supply	14/15
Flue systems	16
Conventional chimneys	16
Balanced flues	17-26
Commissioning	27
Procedure	27
Handing over	27
Servicing	27
Procedure	27/28
Baffle configurations	29/30
Fault finding	31/32
Spares	33
Spares list	33
Assembly drawing	34

INTRODUCTION

The EuroStar will provide domestic hot water and central heating. It is supplied with adjustable boiler control and manual-reset high limit thermostats. The system requires little more attention than the setting of the boiler thermostat and any system controls such as a room thermostat or programmer.

The boiler has been designed and constructed to give years of trouble-free service, and these instructions are provided to assist you in obtaining the best performance with the least trouble and cost.

To help TR Engineering provide the highest levels of customer service, it is important that the registration card is completed in full and returned.

BOILER CONTROL

Starting the boiler

- Ensure the system is full of water, that there is sufficient oil in the storage tank and that all isolation valves are fully open.
- Check that the programmer is **on** and that the room thermostat is calling for heat.
- Set the boiler thermostat (**fig 1**) to the desired water temperature.
- Switch on the electrical supply to the boiler. After a few seconds, the burner should light.
- Set the programmer to activate the boiler for central heating and domestic hot water as required.

The boiler should now operate automatically, switching on and off according to demand.

Boiler control thermostat

The boiler control thermostat (**fig 1**) allows selection of water temperatures at five positions between 55°C and 82°C. Where a cylinder thermostat is also fitted to the system, ensure that the boiler thermostat is set above or equal to the highest setting.

The boiler may be switched off by turning the boiler thermostat fully anti-clockwise. If the boiler is to be inactive for a long period, switch off the mains supply and/or set the programmer to the off position.

High-limit thermostat

The high-limit thermostat is factory set and cannot be adjusted. Should the water temperature rise to 110°C, the limit thermostat will shut the appliance down.

The limit thermostat reset button is located on the rear of the boiler control box (**fig 1**). The limit thermostat can only be reset when the water temperature in the boiler has dropped by at least 20°C.

If the limit thermostat operates frequently, consult a service engineer, as there may be a fault in the system.

Burner lock-out

If the burner fails to light, it will go into a lockout mode, indicated by illumination of the reset button on the burner (**fig 2**). Press the button. If a lockout reoccurs, wait for one minute before pressing the button again.

If the problem persists, follow the faultfinding guide on **page 5** before switching off the electrical supply to the boiler and contacting a service engineer.

DO NOT reset the burner more than twice in one failure period, as repeated attempts to do so may cause permanent damage to the internal components.

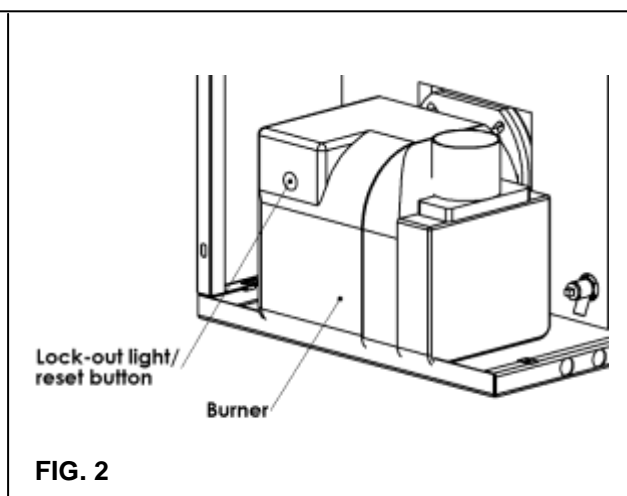
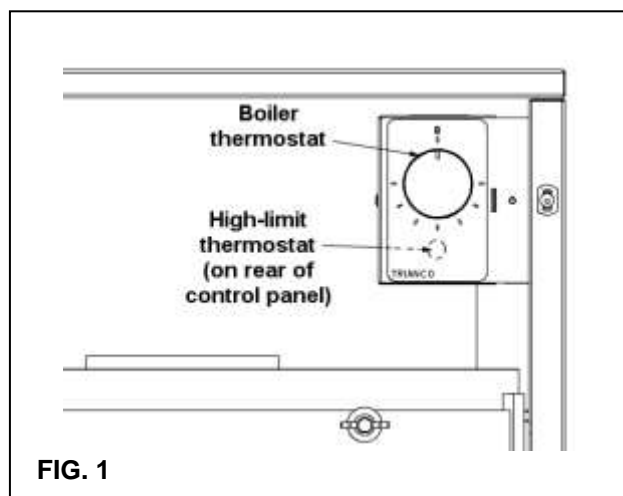

SYSTEM CONTROLS

Room thermostat

To prevent the boiler switching off before the room has reached the required temperature, the room thermostat should not be positioned near a heat source, such as a radiator, or be exposed to direct sunlight. Follow the manufacturer's guidance for optimum siting positions.

Programmer

When choosing the operating times for the boiler, remember that the central heating system may take up to one hour before becoming effective, and will usually remain warm for up to half an hour after the boiler has switched off. As such, it may be possible to switch the programmer off early as an economy measure.

Frost protection

If the boiler is to be switched off during very cold weather, or is located in a boiler room external to the property that is being heated, the water may be in danger of freezing. This can be prevented by fitting the boiler with a frost thermostat that will cause the boiler to light if the temperature nearby drops too low.

Where the system is not protected, the boiler can be left on and the room thermostat set to a low position (e.g. 5°C).

System shut-down

If the system is off for long periods during very cold weather, it may be advisable to completely drain the system. Be aware that too frequent draining should be avoided especially in hard water areas as this could lead to scale build-up in the boiler waterways.

If the boiler is to be shut down for the summer months, it is advisable to have it serviced as soon as possible, to minimise the risk of corrosion to the heating surfaces.

OIL

The only heating oil suitable for use on this boiler is kerosene class C2. **DO NOT** use any other heating oil. Failure to use the correct oil will invalidate the warranty.

Ensure the oil storage tank is topped up regularly; do not wait until the tank is empty, as sludge and water could be drawn into the supply pipe, adversely affecting the operation of the burner and potentially reducing the life expectancy of the oil pump.

After an oil delivery, allow half an hour for the oil to settle in the tank before using the boiler. Sludge and water caused by the build-up of condensation

should be drawn off at the drain cock on the tank once per year.

FAULT-FINDING

If the boiler fails to start, carry out the following checks before contacting your service engineer:

- Check for failure in the electrical supply
- Check for a blown fuse. If the fuse has blown and the replacement also blows, switch off the mains electrical supply to the boiler and contact your service engineer.
- Check that there is oil in the tank and that all isolation valves are fully open.
- Check for burner lockout (**page 4**).
- Check that the boiler thermostat is switched on and that the programmer and room thermostat are calling for heat.
- Check that the high-limit thermostat has not operated (**page 4**).

Note: if the boiler has been shut down due to a failure of the electrical supply, it may be necessary to reset the programmer to the correct time, unless the device has an in-built power reserve.

See **pages 30–31** for comprehensive faultfinding guidance for engineers.

COMMISSIONING & SERVICING

To ensure the continued efficient and reliable operation of the boiler, it is essential that the burner be commissioned immediately after installation and prior to first use. The boiler requires an annual service thereafter.

Important notes

It is a requirement of the guarantee and any extended warranty that the boiler is commissioned and receives an annual service. It is the responsibility of the installation engineer to ensure commissioning is carried out.

Commissioning and servicing must be performed by a qualified engineer, preferably OFTEC trained and registered. Electrical safety checks should be carried out by a qualified electrical engineer.

It is a requirement of the guarantee and any extended warranty that the system is flushed out and protected with an appropriate corrosion inhibitor, e.g. Fernox.

AFTER SALES SERVICE INFORMATION

A qualified field service engineer is available to attend a breakdown occurring during the boiler's guarantee period.

The boiler must be made available for attendance during normal working hours, Monday to Friday.

How to report a fault

Step 1

Contact your installation or service engineer, who should assess the unit and works carried out on the appliance prior to requesting the attendance of an engineer from TR Engineering Ltd.

Step 2

Please note that upon attendance by a TR Engineering engineer, a charge will be made where:

- The engineer finds no fault with the boiler.
- The cause of the breakdown is due to parts of the system not manufactured or supplied by TR Engineering.
- The cause of the breakdown is due to incorrectly fitted spare parts, or third-party spares not designed for use with the boiler.
- The boiler has not been installed in accordance with these instructions.
- The boiler has not been commissioned by a qualified engineer.
- The boiler has not been serviced annually since installation.
- The breakdown occurs outside the guarantee period.
- The appliance has not been maintained correctly.
- The breakdown occurs due to use of the boiler not sanctioned by these instructions.
- The breakdown occurs as a result of work on the appliance by an unauthorised third party.

Important:

Invoices for attendance and repair work by any third party will not be accepted unless authorised in advance by TR Engineering Ltd.

Technical Assistance

A team of trained technical advisors is available to discuss any problem with the appliance. In many cases, the problem may be solved over the telephone, eliminating the need for an engineer's visit.

Before making contact, please have the following information ready:

- The appliance serial number or your unique customer identification number (issued upon registration of the appliance with TR Engineering).
- A description of the fault and any unusual behaviour by the boiler before the failure occurred.
- The installation and commissioning dates, and the details of any annual services.

Appliance Serial No.:	_____
Cust. ID No.:	_____
Installation Date:	___/___/___

Important notes

As a replaceable item, burner nozzles are only guaranteed until the first service.

Over 50% of all service calls are found to have no appliance fault.

Service Centre and Technical Support
Tel: 0114 257 2300 Fax: 0114 257 1419

Hours of Business
Monday – Thursday: 8:30am – 17:00pm
Friday: 8:30am – 14:30pm

INSTALLATION

The EuroStar Band A has been designed to conform to European Directives/Standards BED 92/42/EEC, LVD 2006/95/EC, EMC 2004/108/EC.

The boiler design incorporates a secondary stainless steel heat exchanger to recover heat from the flue gases that is normally lost in conventional oil-fired boilers.

The matched pressure-jet burner is quiet in operation and ensures clean and efficient combustion, with low NOx emissions.

The boiler is suitable for all-normal open-vented central heating and indirect hot water systems. With the appropriate safety equipment, the boiler can also be used with sealed systems up to a working pressure of 3 bar.

Two flow and return sockets are provided to facilitate connections to the heating and hot water circuits.

Due to the high efficiency of the boiler, and to comply with the Building Regulations (Part L), it must be fitted to fully pumped systems only.

The front-mounted access cover permits easy access for removal of the baffles and cleaning of the heating surfaces. If the boiler is installed under a kitchen worktop, this should be made removable to give easier access to the flue gas sample point and condensate cleaning port (see **page 28**).

The only heating oil suitable for use on this boiler is kerosene class C2. **DO NOT** use any other heating oil or a mixture of heating oils. Failure to use the correct oil will invalidate the warranty.

Flues

The boiler is supplied suitably equipped for connection to a conventional chimney, but when installed with a TR Engineering balanced flue kit it becomes a room-sealed appliance. These kits allow the boiler to be installed in a wide variety of site conditions. The balanced flue is available in horizontal, high-level horizontal and vertical formats. All flues are suitable for installation in garages, and conform to the requirements of OFSA100. See **pages 17–26** for balanced flue options.

Flushing and water treatment

The performance of the boiler could be impaired by system debris or the effects of corrosion. New systems must be thoroughly flushed to remove metal filings, solder, machining oils and any other corrosive fluxes or greases before connecting the boiler.

When fitting the boiler to an existing system, clean the system by using an appropriate flushing and descaling agent. Refer to BS 7593 (1992) for guidance.

The system must be protected with a corrosion inhibitor. Flushing agents and corrosion inhibitors must be suitable for use with mild steel boilers and comply with BS 7593 requirements. It is strongly recommended that a suitable anti-freeze product is applied to the system after flushing.

Failure to flush the system and add a corrosion inhibitor may reduce the lifespan of the boiler and will invalidate the guarantee and any extended warranty.

Failure to fit the boiler to a fully pumped system will impede its correct operation and invalidate the guarantee and any extended warranty.

The boiler must not be run without water in the system.

It is the installation engineer's responsibility to ensure that the boiler's output matches the heat requirements of the system. Failure to do so may impede the boiler's correct operation and invalidate its guarantee and any extended warranty.

	15-26	29-36
A	460	460
B	854	895
C	597	672
D	355	404
E	603	660
F	693	761
G	743	821
H	16	16
J	60	60
K	37	37
L	197	198
M	85	85
N	71	71
P	231	231

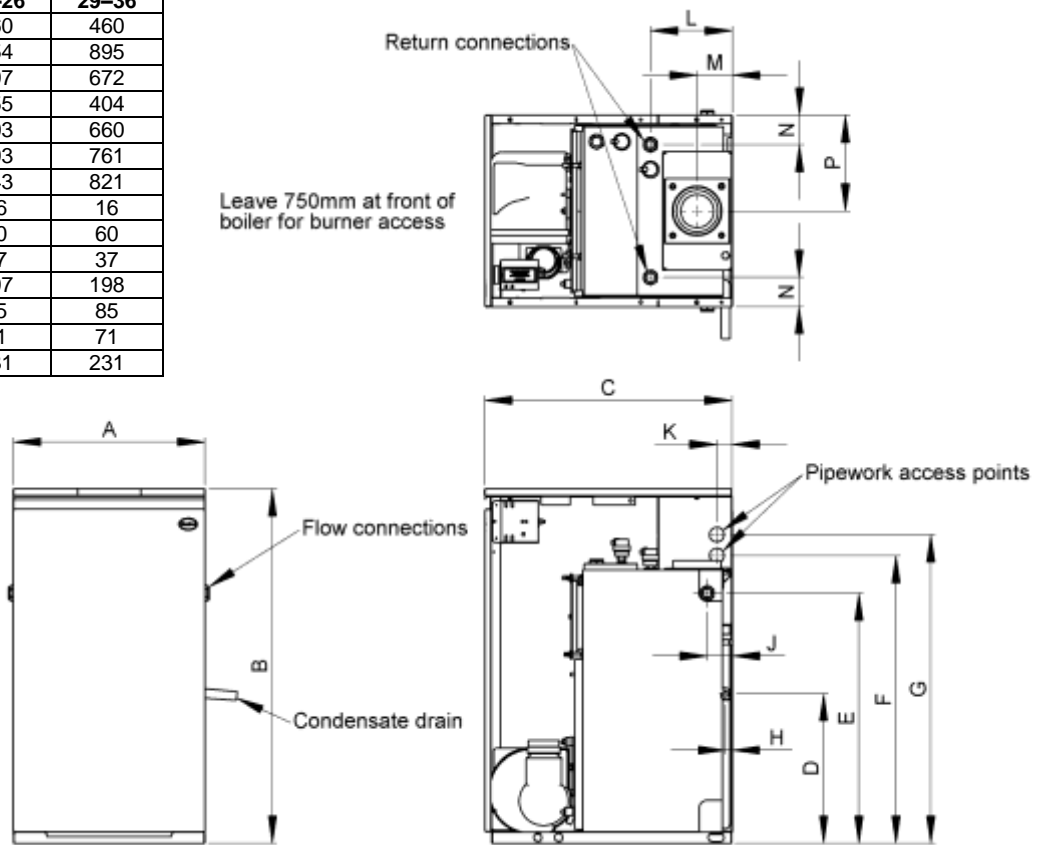

FIG. 3

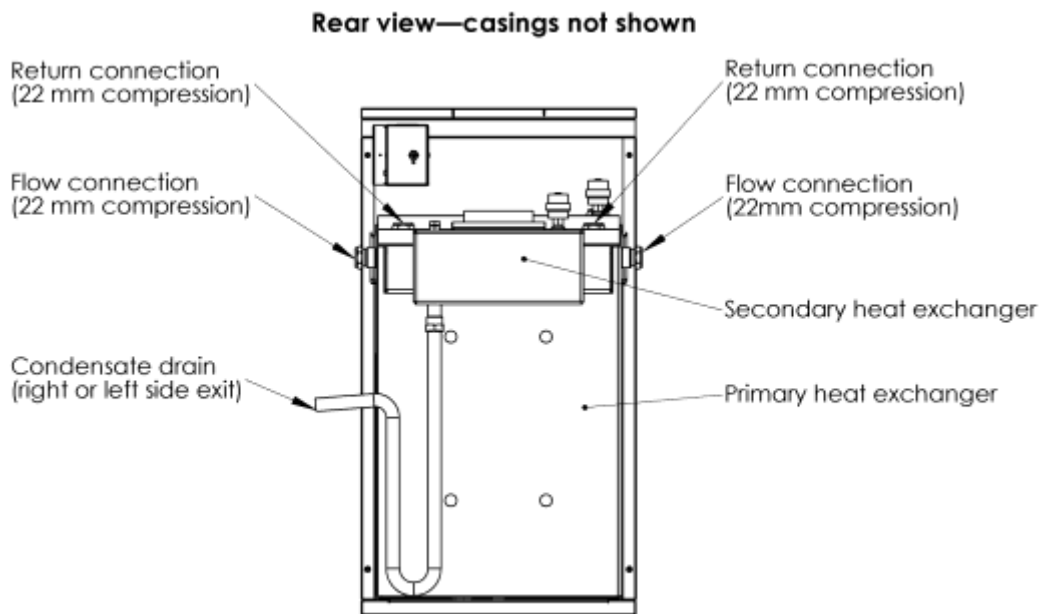

FIG. 4

TECHNICAL SPECIFICATION

	15–20kW	20–26kW	29–36kW
SEDBUK Efficiency Rating	A		
Input¹	18.8kW (64,146 Btu/h)	25.0kW (85,300 Btu/h)	34.3kW (116,929 Btu/h)
Output¹	17.9kW (61,748 Btu/h)	23.0kW (78,476 Btu/h)	33.0kW (112,596 Btu/h)
Weight	130 kg		160 kg
Water Content	26 litres		32 litres
Flow and Return Connections	22mm compression		
Conventional Flue Socket	4" (100mm)		
Maximum Operating Pressure	3 bar (43.5 psi)		
Test Pressure	4.5 bar (65.3 psi)		
Starting Current	3.5 amp		
Running Current	0.77 amp		
Control Thermostat	Adjustable up to 82°C		
Limit Thermostat	Factory-set at 110°C		
Fuel	Kerosene 28s C2 to BS 2869		
Casing Finish	White		
Thermal Insulation	Boiler shell insulated with glass fibre		
Electrical Supply	230/280V – 50Hz fused at 5 amp		
Optional Extras	TR Engineering balanced flue kits (see page 16 onwards)		

Factory Setting

INSTALLATION (cont.)

Regulations

Installation of the boiler must comply with the following:

- BS 5410 Part 1: Code of Practice for Oil-firing.
- BS 5449: Forced Circulation Hot Water Central Heating Systems.
- Building Regulations Part J (England and Wales), Part F section 111 (Scotland), Part L.
- Control of Pollution (Oil) Regulations.
- IEE Regulations (BS 7671).
- Local Water Undertakings Bylaws.
- OFTEC Requirements for Oil-fired Boilers and Oil Storage Tanks, OFST 100 & OFST 200.

Health and Safety at Work Act

The installation engineer should be aware of his or her responsibilities under the Act and provide where necessary appropriate protection for all persons carrying out the installation.

In the interests of safety, the boiler must only be installed, commissioned and serviced by a qualified engineer, preferably OFTEC-trained and registered. A guide to safe working practices for oil engineers is available from OFTEC.

Electrical work should be carried out in accordance with BS 7671 by a qualified electrical engineer.

Plumbing

Due to the condensing nature of the boiler, a plume of water vapour will occasionally discharge from the flue; this should be taken into account when siting the terminal. Refer to **pages 16–17** for details.

Clearance and service access

Ensure adequate clearance is allowed for making the water and flue connections (**fig 3**). If the boiler is installed under a kitchen worktop, this should be made removable to give access to the flue gas sample point and condensate cleaning port (**page 28**). About 750mm should be left at the front of the boiler for service access.

Hearth

The boiler must be installed on a level, non-combustible base that is capable of supporting the installed weight of the boiler, including its water content.

Sound levels

While the low sound level of the boiler makes it suitable for utility room or kitchen installation, the following factors should be taken into consideration before installation:

- Some people are more sensitive to noise levels than others discuss with the householder.
- Small rooms tend to amplify noise, particularly if the room's construction is hollow or the surface tiled.
- A chimney passing through a bedroom will transmit noise.
- Low-level flue terminals produce some exhaust noise, so care should be taken when siting adjacent to neighbouring properties, patios and play areas.

Combustion and ventilation air

The provision of an adequate combustion air supply is essential for the safe and efficient operation of the boiler. The air opening should be positioned to cause the least possible nuisance to the end user, and located in a place that will reduce its likelihood of being accidentally blocked.

As per BS 5410 Part 1 (Code of Practice for Oil), for conventionally-flued boilers a permanent opening of 550mm² per kW of boiler rated output above 5kW is required (see table below and **fig 5**).

Although no combustion air openings are required for balanced-flued boilers, ventilation is required to prevent overheating of the boiler controls if installed in a compartment or other confined space (see **fig 6**).

If the boiler room has an extractor fan, the combustion performance of the boiler must not be affected when the fan is running and all doors and windows are closed. A flue gas analysis on the smoke and CO₂ levels should be carried out to prove that combustion is taking place satisfactorily.

Output (kW)	Detail 'A' (fig 5 & fig 6)
15	55cm ²
17.5	69cm ²
20	83cm ²
23	99cm ²
26	115cm ²
29	132cm ²
33	160cm ²
36	171cm ²

FIG. 5 Conventional Flue

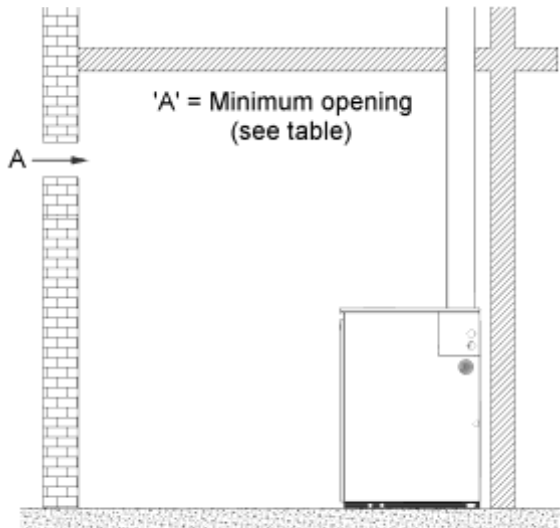

Boiler in a room; combustion air provided direct from the outside

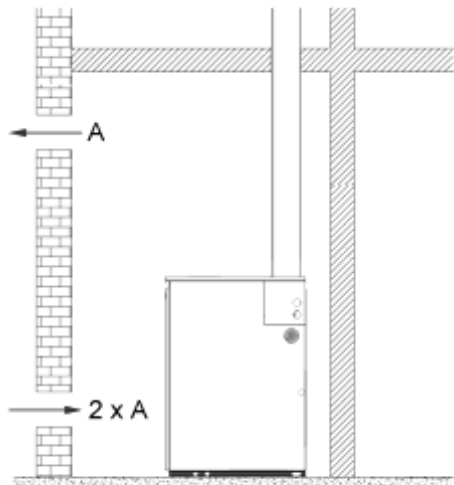

Boiler in a compartment; combustion air provided direct from the outside

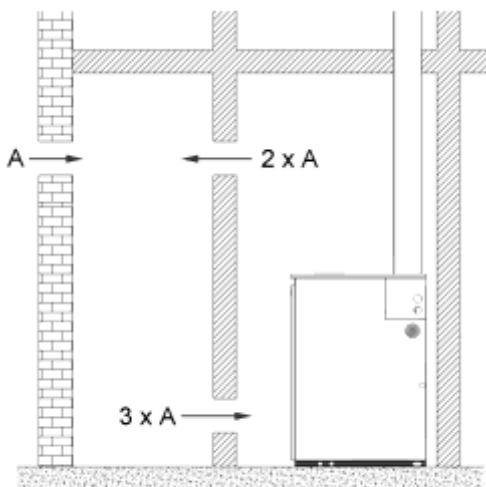

Boiler in a compartment; combustion air provided from adjoining room

FIG. 6 Balanced Flue

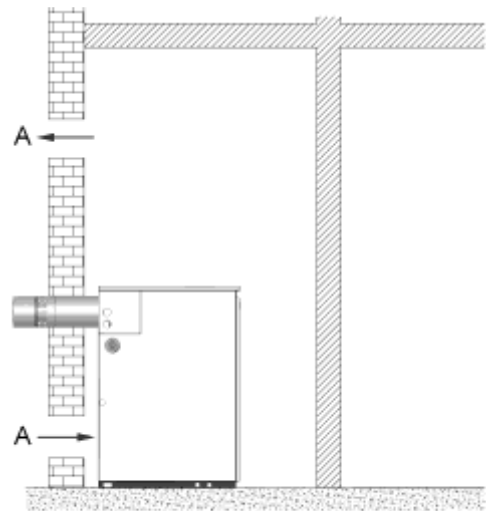

Boiler in a compartment; ventilation air provided direct from outside

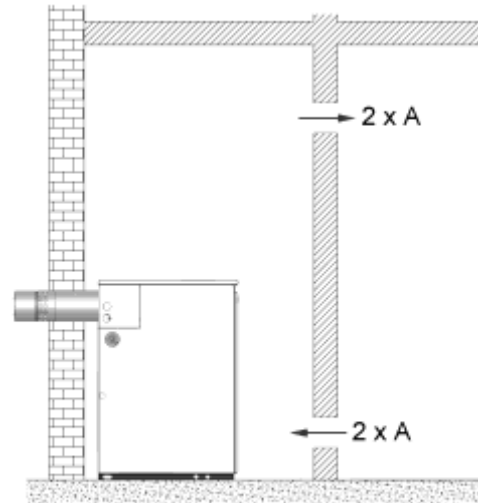

Boiler in a compartment; ventilation air provided from adjoining room

Heating and hot water systems

The heating system should be installed in accordance with current HVCA Codes of Practice and BS 5449 Part 1 (Forced Circulation Hot Water Central Heating Systems).

The water flow connection can be made to one of the two tappings on the left or right side of the boiler. The return connection can be made to one of the tappings on the secondary heat exchanger. See **fig 3** for details.

A drain-off cock should be fitted at the lowest part of the system. Where the boiler is also used for providing domestic hot water, an indirect cylinder to BS 1556 Part 1 must be used.

Flush the system to remove any residue before installing the circulating pump. Ensure all unused tappings are plugged before filling the system.

To achieve maximum system efficiency, the heating system should be designed to ensure a boiler flow temperature of between 55°C and 70°C, and a flow differential temperature of between 20°C and 30°C.

Electrical supply

All electrical wiring must be carried out by a qualified electrician in accordance with current IEE Regulations and any local regulations that apply.

The boiler must be earthed and the supply cables must be longer than the current-carrying conductor cables (i.e. live and neutral supply cables). The minimum requirement for the power supply is PVC sheathed flexible cord, 0.75mm² (24x0.2mm, code designation H05 VV-F or H05 VVH2-F), as specified in table 16 of BS 6500.

The 230V, 50Hz electrical supply must be fused via a double-pole switch with contact separation of at least 3mm in both sides, and via a shuttered socket adjacent to the boiler (both devices must meet the requirements of BS 1363).

All external cables entering the control box must be secured in position through use of the strain-relief bushes (supplied, see **fig 7**).

In certain areas, there may be a known risk of high and low voltage fluctuations; though use of a voltage-sensitive device, the burner should be prevented from starting if the voltage drops or rises to a level sufficient to endanger the installation.

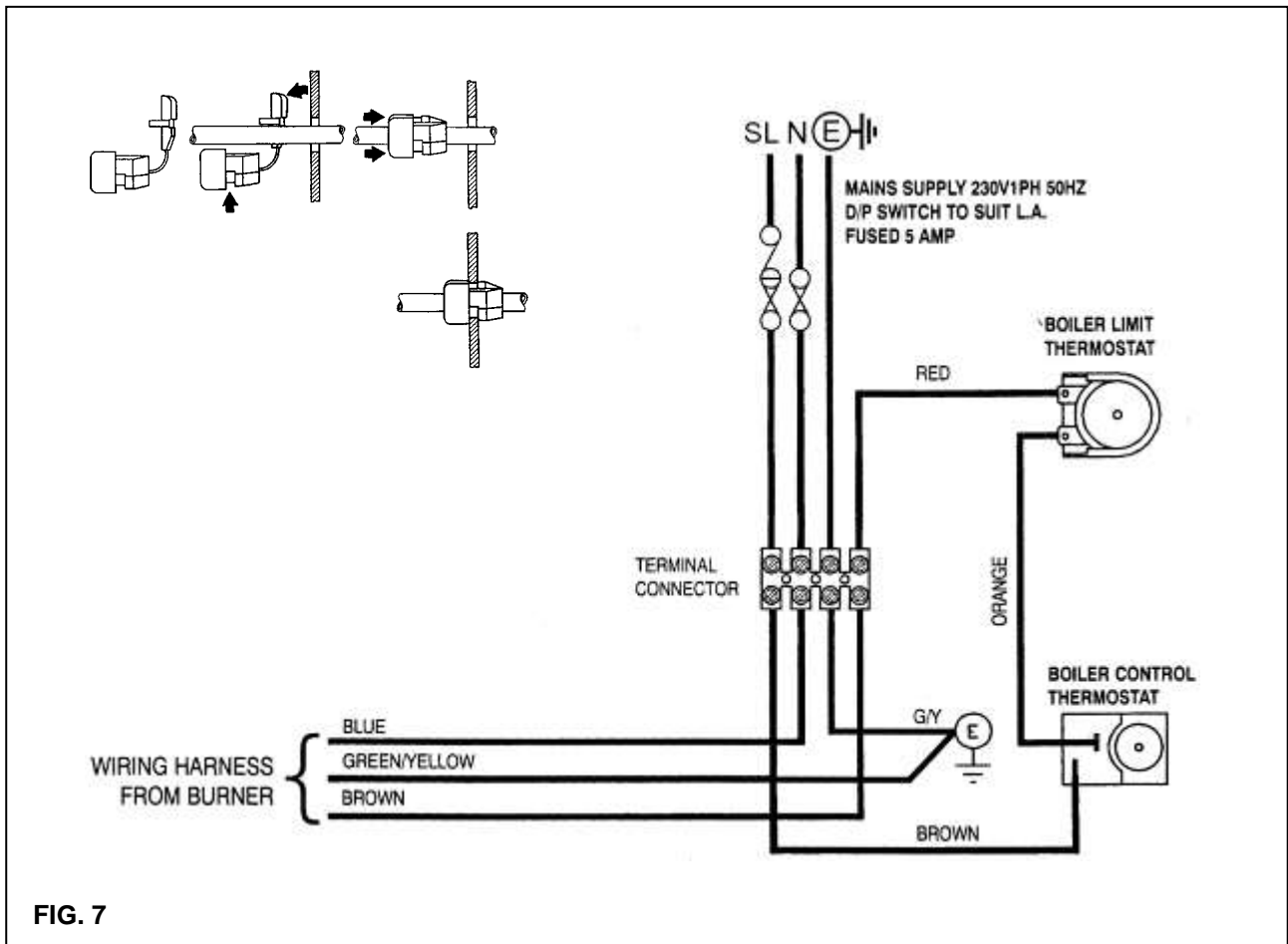

Condensate drain connections

The boiler comes equipped with its own condensate trap in the form of a 22mm 'U'-shaped pipe connected to the secondary heat exchanger. The pipe can be run to the left or right of the boiler; for ease of installation, it should be fitted before the boiler is positioned.

To install the condensate pipe, remove the boiler back casing. After deciding the direction in which to run the pipe, feed the long end through the side casing from inside. Attach the short end (with the connecting nut) to the rear underside of the secondary heat exchanger, ensuring a watertight seal is made (**fig 8**).

After the boiler has been positioned, the trap should be connected to a 22mm plastic or stainless steel pipe (not supplied) to take the excess condensate to a drain or soakaway (where possible, an external drain should be used). The drainpipe should be installed to allow the condensate to drain naturally from the boiler, on a minimum fall of 1:20 (**fig 9**). Insulate any external pipework to prevent the condensate from freezing. **DO NOT** use copper pipework for the condensate drain.

If the boiler is installed below ground level, and there are no internal drains, a condensate pump can be fitted. Refer to manufacturers' instructions for best practise.

The trap must be filled with water to create a seal that stops the escape of flue gases through the drainage pipework. To fill the trap, remove the cleaning port plug from the top of the boiler and pour a small amount of water inside. The trap will have sufficient water when water emerges from the drainage pipe.

DO NOT fire the boiler without first ensuring the condensate trap is filled with water. Failure to do so may result in damage to the pipework, allowing flue gases to escape. Any damage caused as a result of not filling the trap will not be covered by the guarantee.

Examine the pipework and rectify any leaks. The trap should be inspected at regular intervals to ensure correct operation, and it should be checked as part of the annual service schedule.

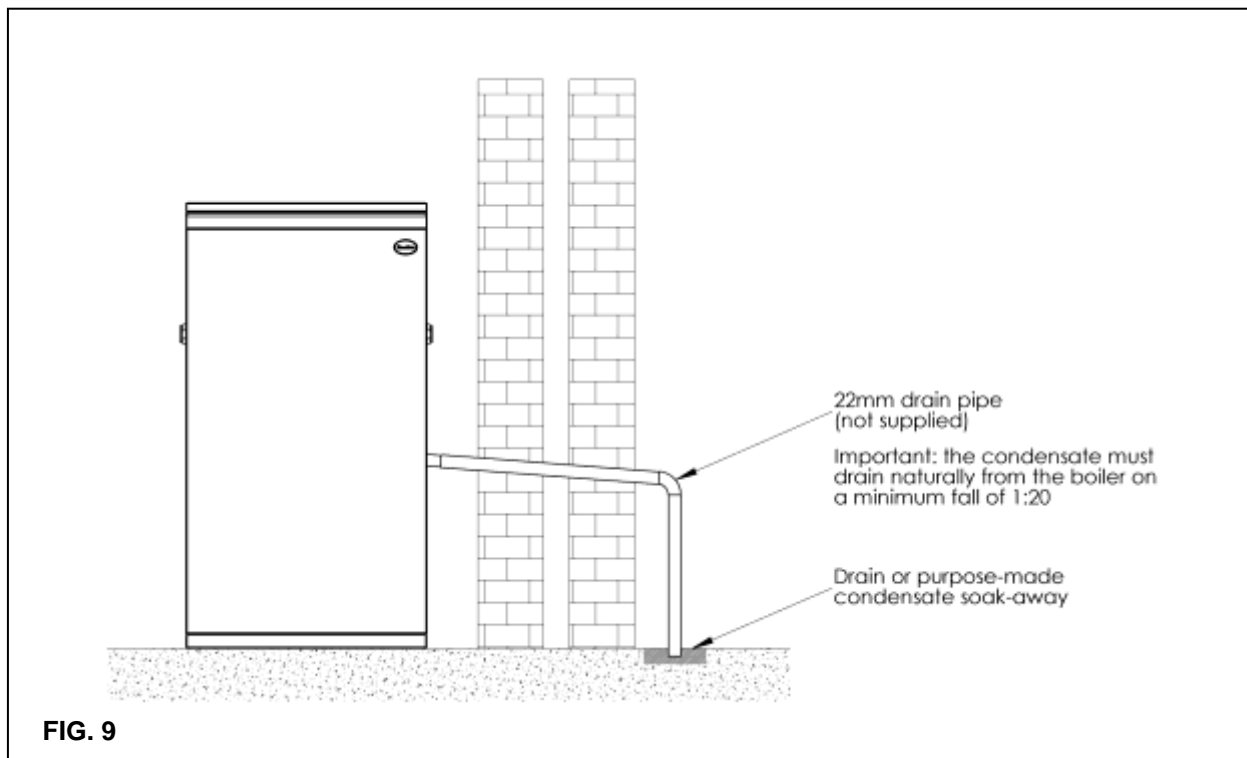
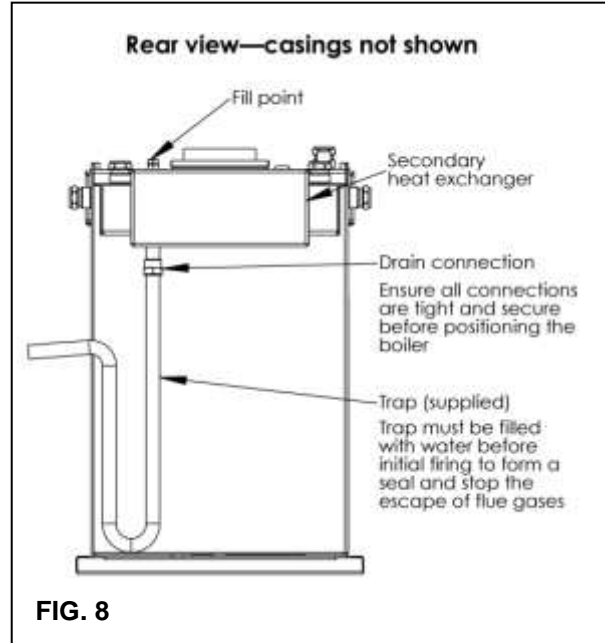

OIL

The burner will only run on kerosene class C2 to BS 2869. Failure to use the correct oil or use of a heating oil mixture will invalidate the warranty.

Storage tank

The oil storage tank should be large enough to allow for an economic delivery schedule. It should be located in an unobtrusive position that nevertheless provides easy access for deliveries and pays regard to safety issues, maintenance and the head of oil required.

The tank should be fitted with weather-protected fill and vent connections, a drain-off and an oil level indicator.

Plastic or Steel tanks may be used, and must comply with the requirements of BS 799 Part 5 (Specification for Oil Storage Tanks). Steel tanks must be mounted on brick or block piers, with a waterproof membrane fitted between the piers and tank.

Fire protection

While it highly unlikely that a fire could start from a domestic oil tank, protection is required from a fire that may originate elsewhere. The tank should be at least 1.8 metres from any building and 750mm from a site boundary. Where it is not feasible to adhere to these limits, the building wall must not have any openings other than those required for ventilation, and the wall must have a fire resistance of half an hour extending at least 1.8 metres from any part of the tank.

Alternatively, a non-combustible radiation barrier meeting the requirements of BS 5410 Part 1 can be fitted. This applies to tanks of up to 3,500 litres capacity.

Fire protection must be provided to the eaves if less than 1.8 metres from the top of the tank. Cladding must extend at least 300 beyond the tank which must be mounted on a non-combustible base.

Pollution protection

The tank must be bunded (double-walled) if:

- The tank is less than 10 metres from a stream.
- The tank is less than 50 metres from a well, spring, or other source of drinking water.
- The tank cannot be seen from the point of delivery.
- There is a risk of oil reaching a manhole cover or drain in the event of a leak.
- The tank capacity exceeds 2,500 litres.

Supply

A long-life flexible oil hose is supplied with the boiler. A filter and shut-off valve are also required. These should be fitted in the positions shown on **figs 10, 11 and 12**.

All oil line joints must be completely sealed and the total pipe run should be thoroughly flushed before connection is made to the burner. **DO NOT** use soldered joints in the oil line.

A remote-operated fire valve must be fitted in the oil supply line, externally to the premises, with the sensing phial located at a point within the boiler casings above the burner.

Single-pipe oil supplies (fig 10)

Where the lowermost part of the tank is above the level of the oil pump on the burner, a single-pipe gravity system can be used. The supply pipe should be connected to the suction port on the burner pump via the flexible hose (supplied).

Two-pipe oil supplies (fig 11)

Where the lowermost part of the tank is below the level of the burner, a two-pipe suction lift is necessary. A second flexible hose will be required, and the oil pump must first be converted for use. See the burner leaflet for details.

A spring-loaded non-return valve must be fitted in the suction line to prevent the back-flow of oil when the burner is not running. No valves are to be fitted to the return line.

The pump suction must not exceed 0.4 bar, as dissolved gas may be released from the oil, affecting combustion. The return pipe must end at the same level as the suction outlet to prevent loss of prime. The tank outlet should be approximately 75mm above the bottom of the tank to prevent the drawing off of sediment and water when the oil begins to run low.

Single pipe oil supplies with a de-aerator (fig 12)

Where a two-pipe suction lift is required, but it is not feasible to fit a return pipe, an oil de-aerator can be used. The burner should be piped and the pump converted as for a two-pipe system, up to the de-aerator, at which point a single pipe can be taken to the storage tank. The de-aerator should be fitted as close to the boiler as possible though externally to the premises at a height no lower than the oil pump.

A non-return valve is not required.

Lift (H)		0.5	1.0	1.5	2.0
8mm ID Supply	Maximum Run (Metres)	10	20	40	60
10mm ID Supply		20	40	80	100

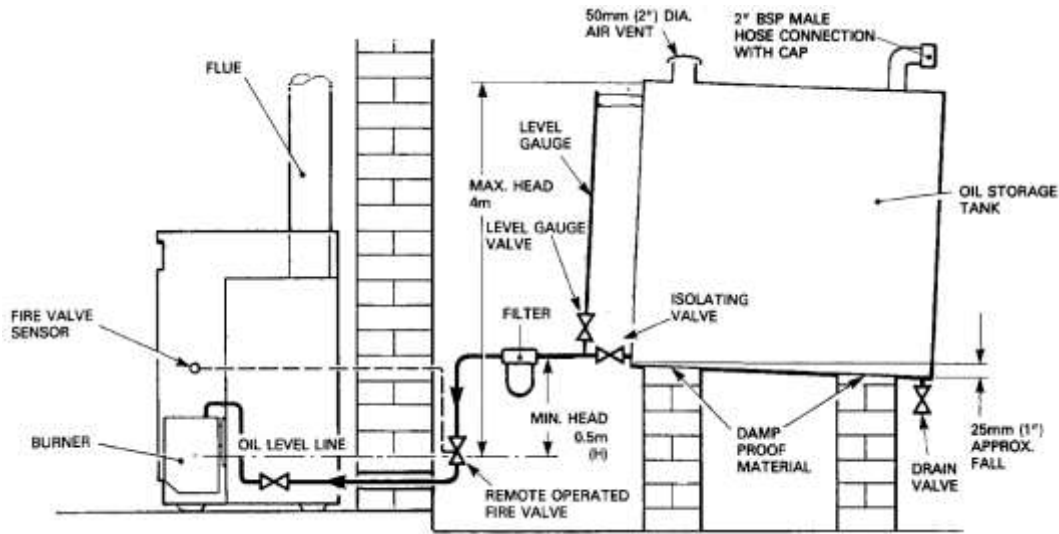

FIG. 10

Lift (H)		0	0.5	1.0	1.5	2.0	3.0	3.5
8mm ID Supply	Maximum Run (Metres)	35	30	25	20	15	8	6
10mm ID Supply		100	100	100	90	70	30	20

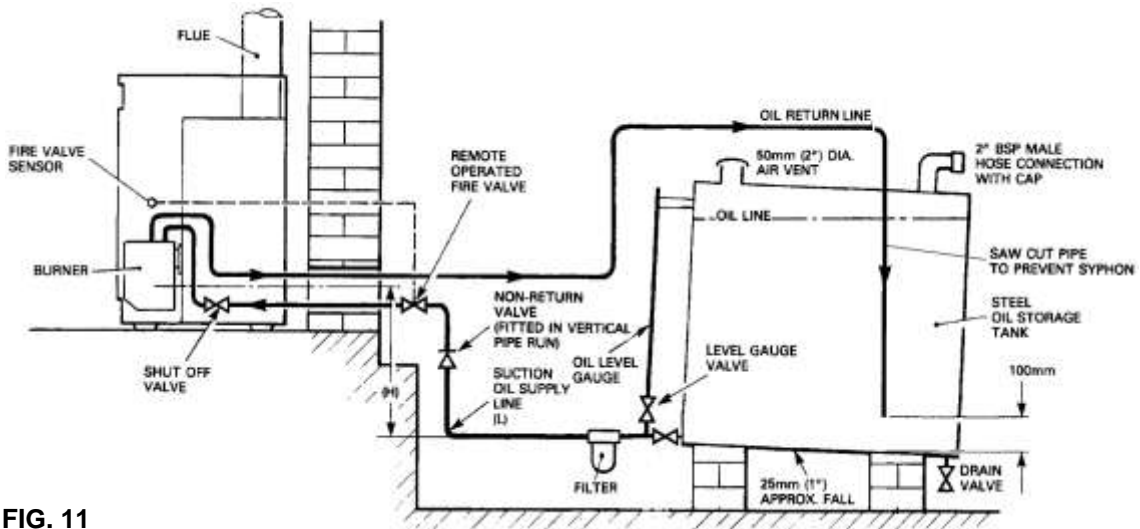

FIG. 11

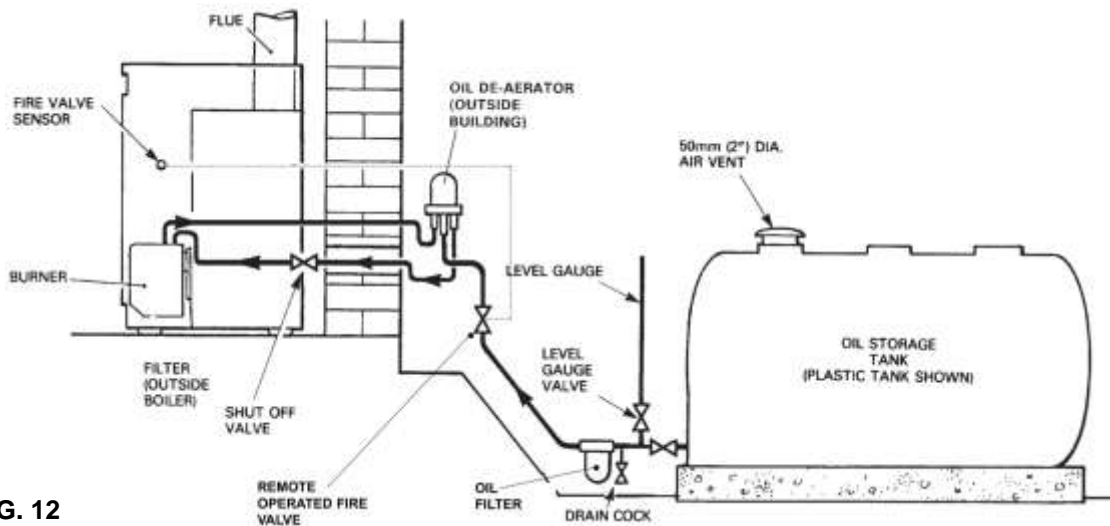

FIG. 12

FLUE SYSTEMS

To evacuate the products of combustion safely and thoroughly, the boiler must have an efficient flue system. **DO NOT** fit a new boiler to an older flue system.

Conventional chimneys

The Contractor boilers operate at high efficiencies, with low flue gas temperatures. All components used in the flue system must be suitable for wet flues, and approved for use with condensing oil boilers.

The flue should rise as vertically as possible, and terminate at a point not subject to downdraughts and adverse wind effects. The condensation produced in the flue should be allowed to run back into the boiler; no separate drain in the base of the flue is required.

Where a chimney is used, it must be lined with a stainless steel liner suitable for use with oil-fired condensing boilers. Before the liner is installed, the chimney must be thoroughly cleaned of all traces of soot and scale.

If a rigid flue is to be fitted externally, a twin-walled flue must be used. The flue must be constructed of a stainless steel inner skin (suitable for use with oil-fired condensing boilers). It must also be insulated, incorporate seals and be weather-protected.

The internal flue diameter must be 100mm (4").

Aluminium or plastic must not be used on any part of the flue system.

The boiler will operate reliably over a wide range of chimney draughts; as such, under normal circumstances the flue should terminate with a standard cowl.

Ensure that all joints on the flue system are adequately sealed, and that no gases or condensation can escape.

Balanced flues

The Trianco balanced flue system offers greater flexibility for siting than a conventional flue. In addition to the siting benefit, the performance of balanced flue boilers is virtually unaffected by high wind conditions, as the wind pressures are applied equally to both the air intake and flue gas discharge sections, creating the balanced condition. Balanced flue condensing boilers are also designed to operate at low noise levels.

Some boilers rely on case sealing; Trianco boilers do not require case sealing; Trianco boilers do not require case sealing as they have a sealed air duct system that maintains the room sealed performance even when the front casing is removed for burner commissioning or adjustment.

The use of the balanced flue principle also enhances the overall thermal efficiency of the boiler, as the incoming air extracts waste heat from the flue and returns it as pre-heated air to the burner, aiding combustion.

Three types of balanced flue can be fitted to the boiler: horizontal (**pages 18–19**), high-level horizontal (**pages 20–22**), or vertical (**pages 23–25**). Bends can

be fitted to the vertical or high-level kits for further siting flexibility (**page 26**).

During operation, a plume of condensation will frequently discharge from the flue terminal. As such, care should be taken when siting the flue to avoid a nuisance to neighbouring properties. Keep the terminal clear of infrared sensing devices, such as those used to control security lighting or alarms. Positioning of flues under balconies and within carports should also be avoided.

The flue terminal should not be positioned where the products of combustion could enter the building (see **fig 14**). Additional clearances may be allowed to prevent plume nuisance (**fig 15**). If the terminal is less than 2 metres above ground level or any other place to which a person has access, the terminal must be protected by an appropriate guard. As the system operates under positive pressure, it is essential that all flue joints are sealed.

Trianco balanced flue kits have been designed for exclusive use with Trianco boilers; as such, compatibility with other manufacturers' boilers cannot be guaranteed.

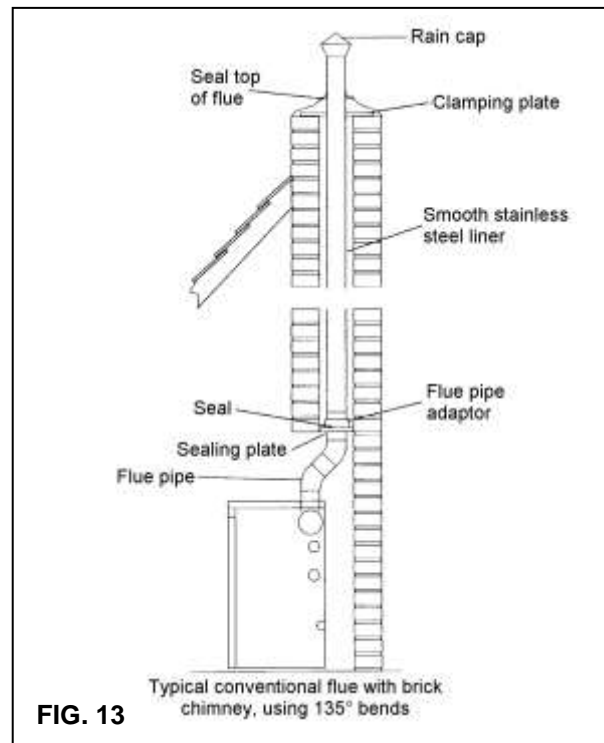

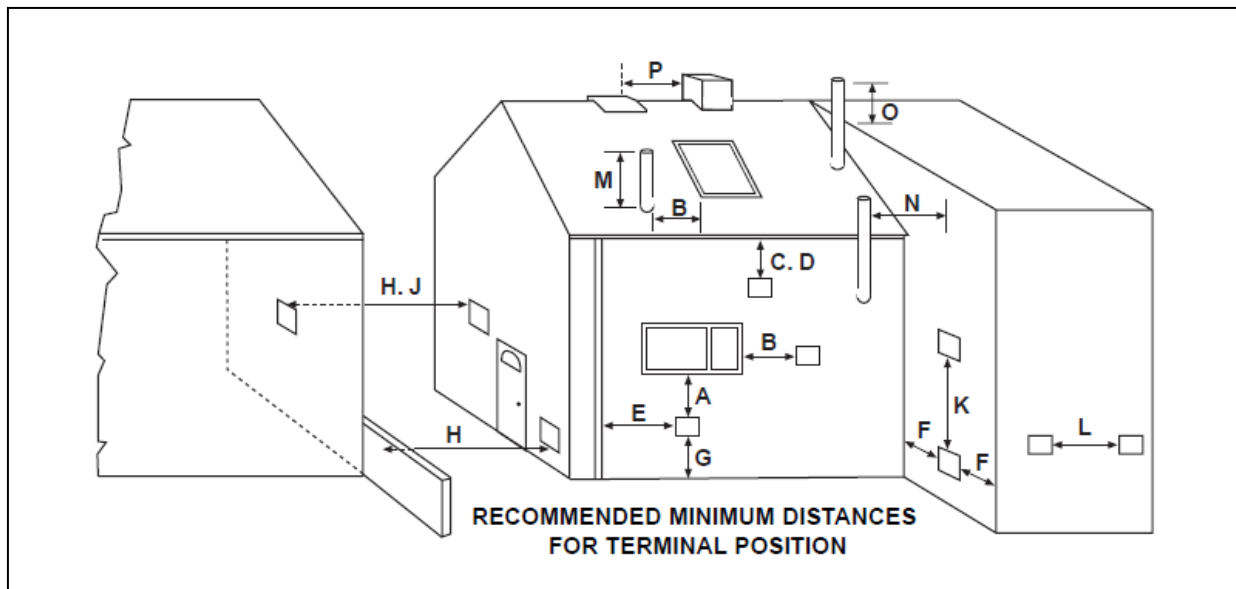

**Minimum clearances as measured from top of chimney
or rim of low-level discharge terminal. All distances in mm.**

A	Directly below an opening (e.g. a window or air brick)	600	H	From a surface or boundary facing the terminal	600
B	Horizontally to an opening	600	J	From another terminal facing the terminal	1200
C	Below a gutter, eaves or a balcony (with protection)	75	K	Vertically from a terminal on the same wall	1500
D	Below a gutter, eaves or a balcony (without protection)	600	L	Horizontally from a terminal on the same wall	750
E	From vertical sanitary pipework	300 (600*)	M	Above the highest point of an intersection with the roof	600
F	From an internal or external corner	300 (600*)	N	From a vertical structure to one side	750
G	Above ground or balcony level	300 (600*)	O	Above a vertical structure less than 750mm to one side	600
			P	From a ridge terminal to a vertical structure on the roof	1500

* Scotland

FIG. 14

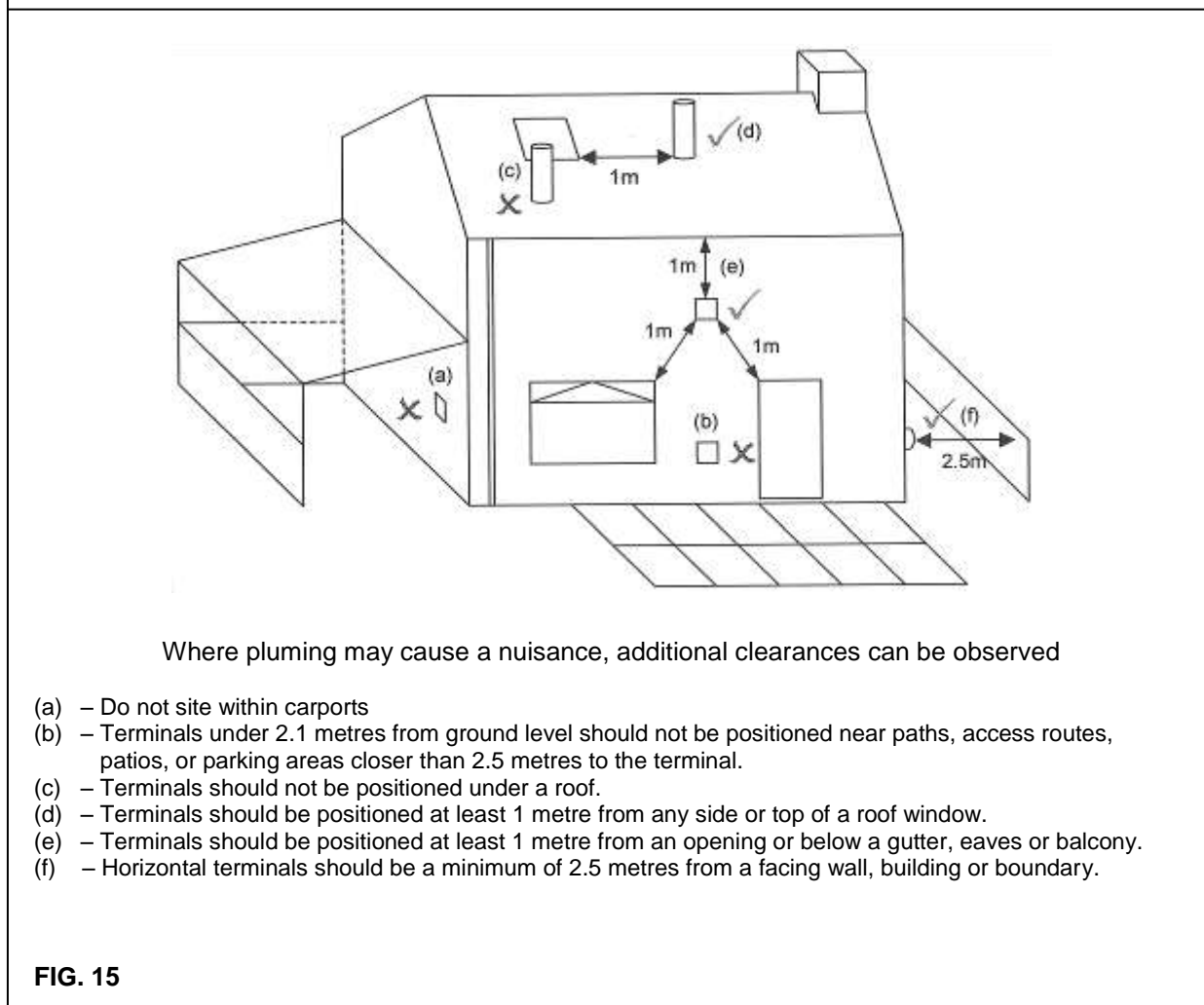

FIG. 15

**Horizontal balanced flue assembly
(kits 2334 & 2335)**

Before starting, ensure the placement of each section has been identified and that all 'o'-ring seals are in position and well-lubricated.

Important: it is essential that the flue inclines slightly up from the boiler to allow condensation to run to the drain.

- Having decided the position of the boiler, mark out the position of the terminal and cut a circular hole 130mm diameter in the wall (see **figs 17–18**).
- Remove the boiler top casing and the four nuts that hold the flue socket and gasket to the top of the heat exchanger. Remove the flue socket, but leave the gasket in place.
- Fit the sealing plate (**item 4, fig 16**) over the four studs and place the terminal gasket (**3**) over the sealing plate. Position the boiler.
- Assemble the flue by sliding the terminal section (**2**) into the elbow section (**1**), ensuring that all 'o'-rings (**6**) are in position. Slide the completed assembly through the wall from the inside.
- Slide the flue mounting plate on the elbow section over the four studs on the top of the heat exchanger and secure in position using the four nuts previously removed.

- Adjust the terminal length as required, ensuring a minimum distance of 140mm is kept from the end of the terminal to the external face of the wall. See **figs 18–19** for allowable distances.
- Connect the air hose from the burner to the socket on the near end of the flue, using the jubilee clip provided.
- To ensure that any condensate produced in the flue drains away correctly, incline the flue 1° upwards from the boiler. Seal around the terminal on the inside and outside wall with an appropriate material.

As the flue operates under positive pressure, all flue joints must be well-sealed. To aid assembly, it may be necessary to apply a thin bead of silicone grease to all flue joints that incorporate 'o'-ring seals. All joints that do not incorporate 'o'-ring seals should be sealed with silicone sealant.

As the boiler produces condensate during normal running, it is important that all seals are made and the correct gaskets used.

Where the terminal is positioned below 2 metres, or in a place accessible to people, an approved terminal guard will be required. A suitable stainless steel terminal guard is available from TR Engineering (part code **223920**).

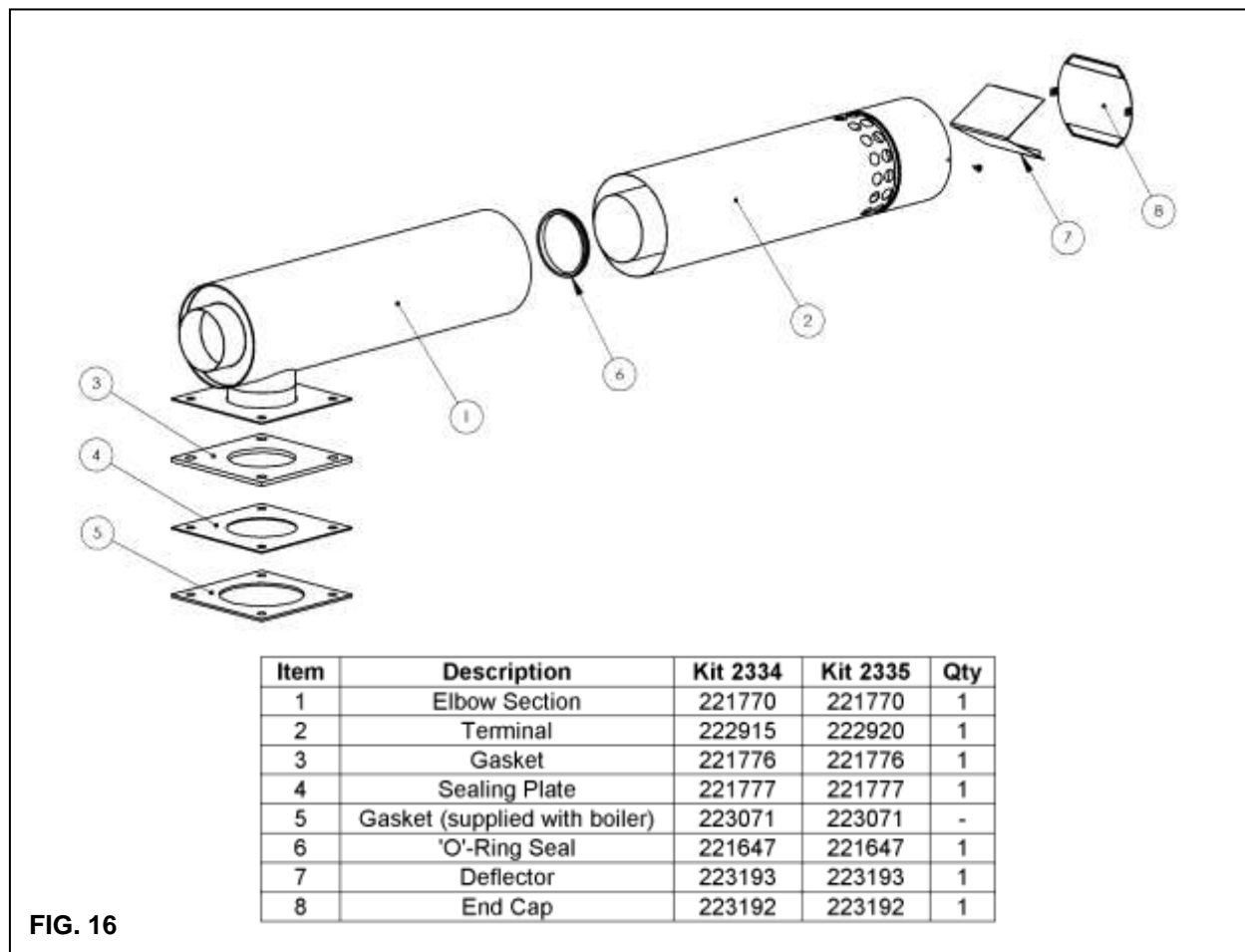

FIG. 16

2334 – 600mm Horizontal Balanced Flue Kit

Model	Dim 'A'
15-20	746mm
20-26	746mm
29-36	794mm

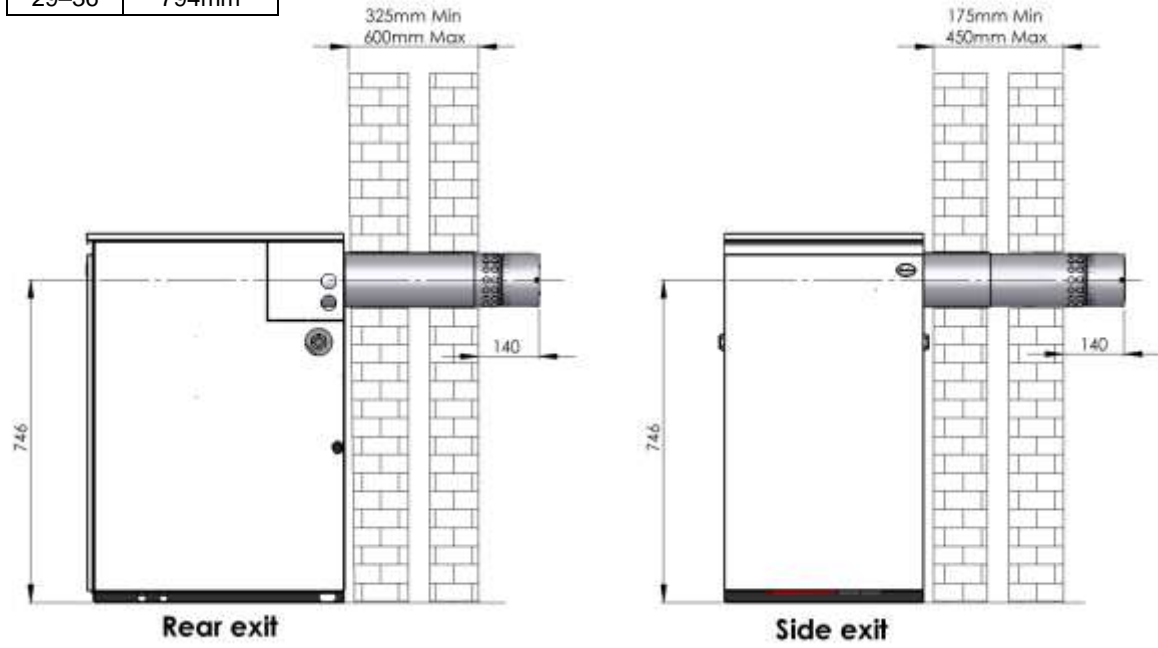

FIG. 17

2335 – 1000mm Horizontal Balanced Flue Kit

Model	Dim 'A'
15-20	746mm
20-26	746mm
29-36	794mm

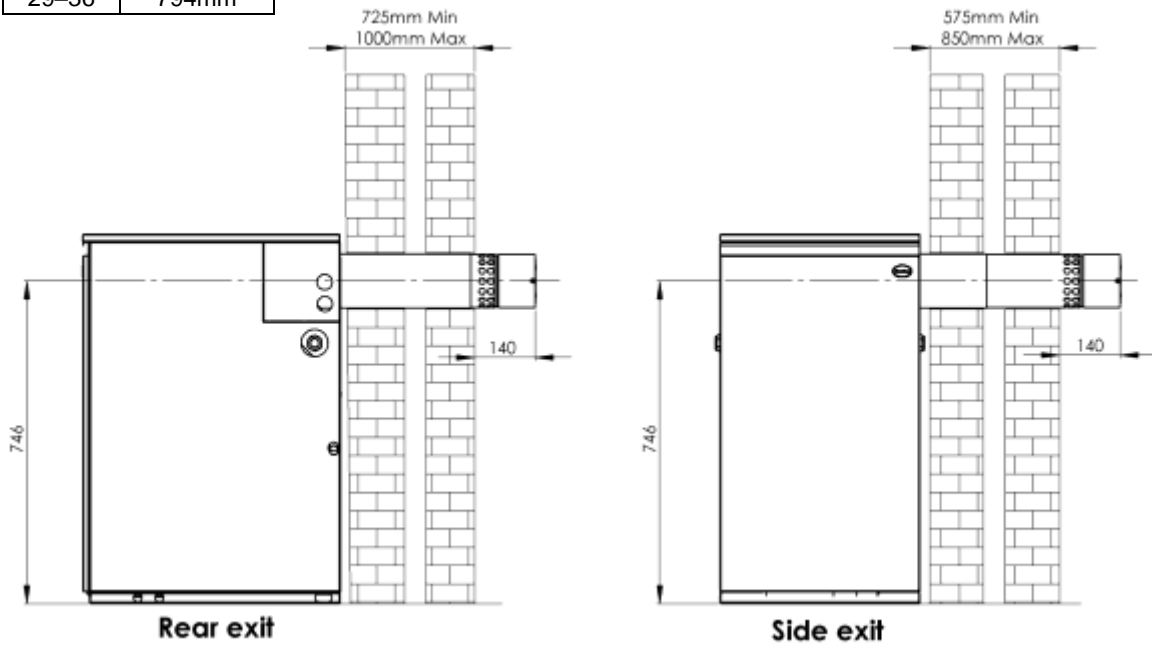

FIG. 18

High-level balanced flue assembly (kit 2357 in conjunction with 2355 or 2356)

Before starting, ensure the placement of each pipe section has been identified (**fig 19**), and that all 'o' rings are in position and are well lubricated. Any white pipe exposed to the elements should be protected with a suitable material. Place all weld seams to the rear.

Important: it is essential that the horizontal flue section inclines slightly up from the boiler to allow condensation to run back to the drain.

Before assembly, determine the length of flue required and if necessary discard the middle section. See adjacent for details of different available flue lengths.

- Having decided the position of the boiler, mark the position of the terminal and cut a circular hole 130mm diameter through the wall.
- Remove the boiler top casing and the four nuts that hold the flue socket and gasket to the top of the heat exchanger. Remove the flue socket, but leave the gasket in place.
- Referring to **fig 19**, secure **items 8, 7, 6 & 5** in order on to the top of the heat exchanger, using the nuts previously removed.
- Fit the lower flue section (**4**) to the spigot (**6**) now situated on top of the heat exchanger and ensure the hose connection is directed to the front.
- Fit the flue mid-section (**3**) and any other optional flue lengths to the preceding flue lengths in the same manner, pushing firmly down until the outer sections meet (but do not overlap). Use the clamping strap (**2**) to secure the outer sections together.
- Fit the horizontal flue elbow (**item 1, fig 20**) to the top of the flue mid-section. Push firmly together until the outers meet and secure with the clamping strap.
- Slide the terminal (**4**) into the horizontal mid-section (**2**). Adjust the horizontal length as required, ensuring a minimum distance of 140mm is kept from the end of the terminal to the external face of the wall. Seal the outer horizontal sections together with a suitable material. See **figs 21–22** for allowable distances.
- Slide the completed terminal assembly through the wall from the inside and fit to the flue elbow. Push firmly together until the outers meet and secure with the remaining clamping strap.
- Use the jubilee clip provided to secure the air hose from the burner to the hose connection on the lower flue section.
- Remove the tabs from the cutout in the boiler top casing and fit the casing in position around the flue.
- Perform a final check of the flue. Ensure clamping straps are located over all relevant flue joints.

- To ensure that any condensate produced in the flue drains away correctly, incline the flue 1° upwards from the boiler. Seal any remaining gaps in the wall around the flue with a suitable material.

Should the height of the flue (**figs 21–22**) not meet your requirements, alternative heights can be achieved by discarding and adding different lengths. The vertical mid-section (**item 3, fig 19**) can be discarded to subtract 750mm from the total height. In this case, the horizontal elbow should instead be fitted to the lower flue section (**4**) in the same manner.

Alternatively, additional sections of pipe can be purchased to meet more specific requirements. Additional 45° elbows can also be purchased to offset the vertical flue run. See **page 26** for details.

For outputs 15–26 kW, the total flue run vertical and horizontal must not exceed 6000mm. For outputs of 29–36 kW, the total flue run must not exceed 4000mm. Any 45° elbows contribute 500mm each to the calculation. The 90° bend contributes 1000mm.

Where the terminal is positioned below 2 metres, or in a place accessible to people, an approved terminal guard will be required. A suitable stainless steel terminal guard is available from TR Engineering (part code **223920**).

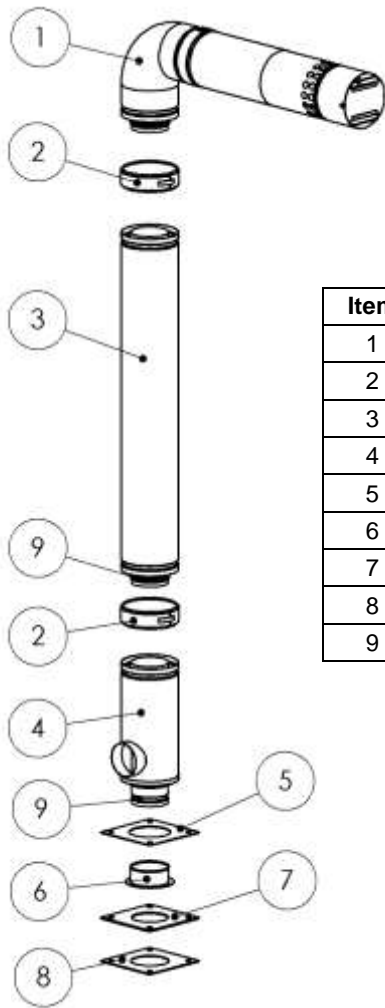

Item	Description	Part No.	Qty
1	Horizontal Flue	2355 or 2356	1
2	Clamping Strap	222899	2
3	Vertical Flue Mid-Section	222867	1
4	Vertical Flue Bottom Section	222820	1
5	Spigot Sealing Plate	222825	1
6	Spigot	222819	1
7	Sealing Plate Gasket	223198	1
8	Flue Sealing Plate	223191	1
9	'O'-Ring Seal	221647	2

FIG. 19

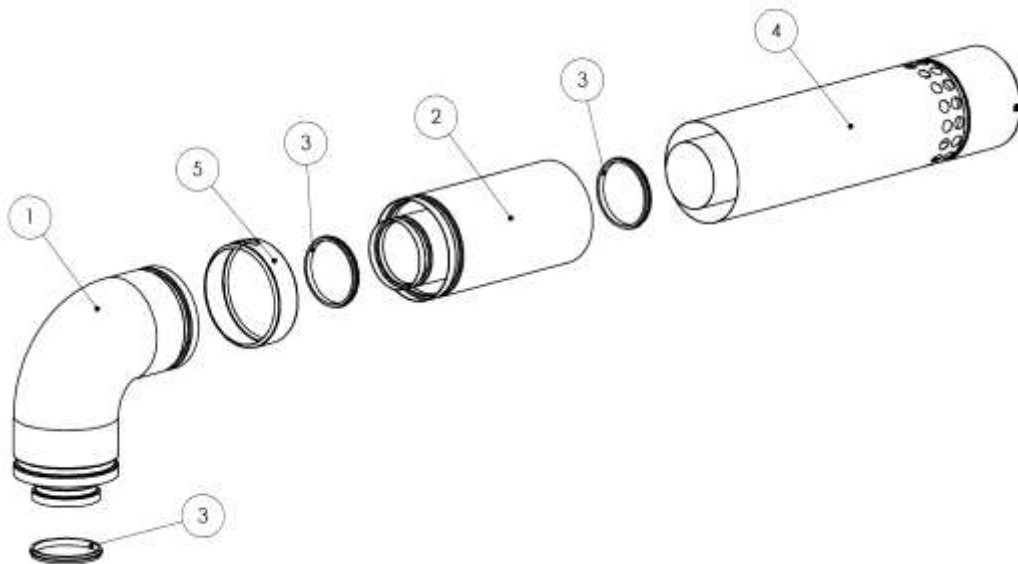

Item	Description	Part No. (Kit 2355)	Part No. (Kit 2356)	Qty
1	Elbow	222826	222826	1
2	Mid-Section	222818	222818	1
3	'O'-Ring Seal	221647	221647	3
4	Terminal	222915	222920	1
5	Clamp	222899	222899	1

FIG. 20

Model	A	B
15-20	1892	1038
20-26	1892	1038
29-36	1940	1046

2357 – High Level Adaptor Kit used with
2355 – 600mm Horizontal Balanced Flue kit

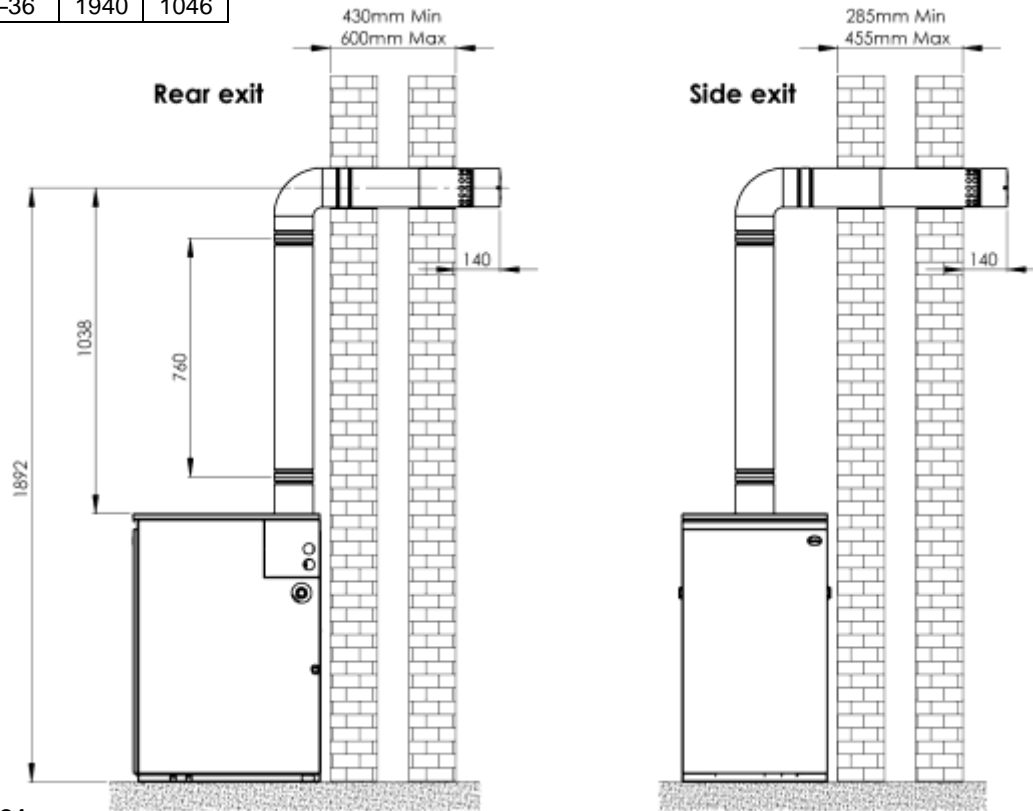

FIG. 21

Model	A	B
15-20	1892	1038
20-26	1892	1038
29-36	1940	1046

2357 – High Level Adaptor Kit used with
2356 – 1000mm Horizontal Balanced Flue Kit

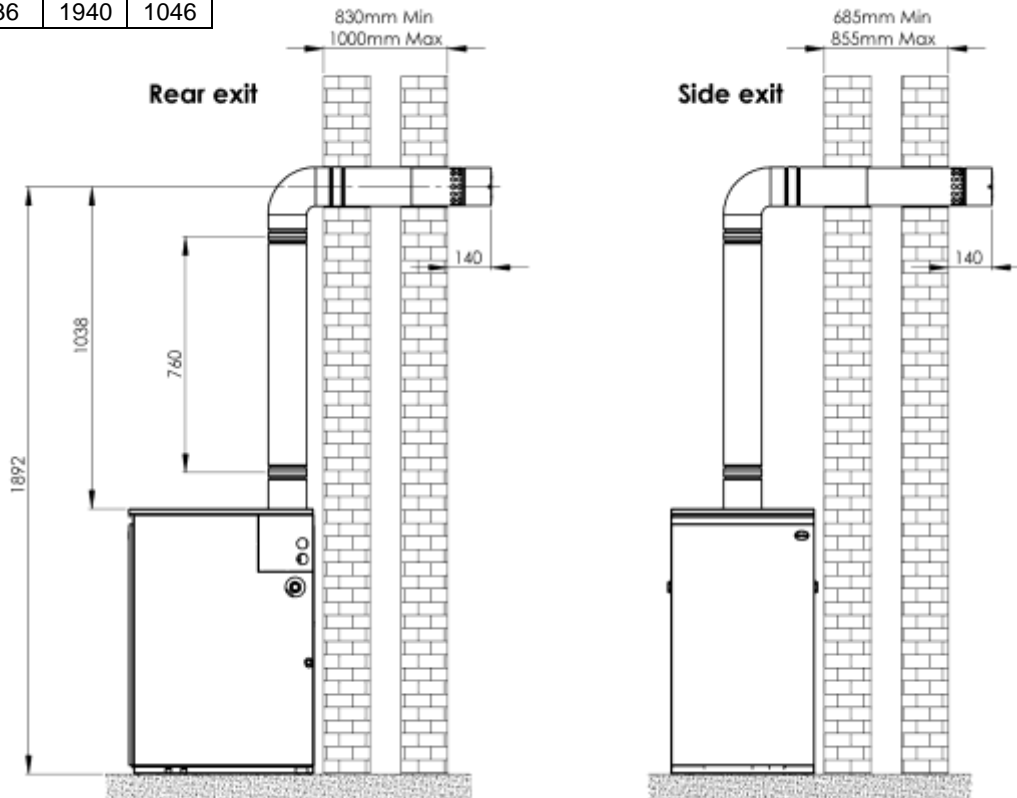

FIG. 22

Vertical balanced flue assembly (kit 2360)

Before starting, ensure the placement of each pipe section has been identified (**fig 23**), and that all 'o'-rings (**item 5**) are in position and are well lubricated. Any white pipe exposed to the elements should be protected with a suitable material. Place all weld seams to the rear.

It may be useful to fully assemble the flue on the ground before fitting to the boiler. Before assembly, determine the length of flue required and if necessary discard the midsections (**item 7, fig 23**). See **fig 25** for flue dimensions; see adjacent for details of different available flue lengths.

- Having decided the position of the boiler, mark the position of the terminal and cut a circular hole 175mm diameter in the ceiling and roof. Ensure the flue will have a minimum clearance of 25mm from any combustible material.
- Remove the boiler top casing and the four nuts that hold the flue socket and gasket to the top of the heat exchanger. Remove the flue socket, but leave the gasket in place.
- Referring to **fig 23**, secure **items 1, 2, 3 & 4** in order on to the top of the heat exchanger, using the nuts previously removed.
- Fit the lower flue section (**6**) to the spigot (**3**) now situated on top of the heat exchanger and ensure the hose connection is directed to the front.
- Fit the first flue mid-section (**7**) to the lower flue section, pushing firmly down until the outer sections meet (but do not overlap). Use the clamping strap (**11**) to secure the outer sections together.
- Fit the second flue mid-section (**7**) and the third flue section (**8**) to the previous sections in the same manner.

Note: Both instances of **item 7** can be discarded if they are not required. Of the main flue lengths, only **6 & 8** are mandatory.

- Fit the terminal extension (**9**) over the preceding flue section. This section does not make use of a clamping strap to allow greater flue length variation, the fit is telescopic. When the position has been set, drill through the **outer pipes only** and secure with self-tapping screws.
- If necessary, fit the terminal (**10**) to the terminal extension before it is attached to the third flue section (**8**). Push firmly down until the outer sections meet and secure with the stainless steel clamping strap (**12**).
- Fit the ceiling plate's (**13**) centrally over the hole in the ceiling. Pack the space around the flue with a suitable insulation.
- Secure the flue in the roof space and fit waterproof flashing (not supplied) around the flue at the roofline.

- Use the jubilee clip provided to secure the air hose from the burner to the hose connection on the lower flue section.
- Remove the tabs from the cut-out in the boiler top casing and fit the casing in position around the flue.
- Perform a final check of the flue. Ensure clamping straps are located over all relevant flue joints.

Should the height of the flue (**fig 24**) not meet your requirements, alternative heights can be achieved by discarding and adding different lengths. The midsection (**7**) can be discarded, or additional sections of pipe can be purchased to meet more specific requirements. Additional 45° elbows can be purchased to offset the vertical flue run. See **page 26** for details.

For outputs 15–26 kW, the total flue run must not exceed 6000mm. For outputs 29–36 kW, the total flue run must not exceed 4000mm. Any 45° elbows contribute 500mm each to the calculation.

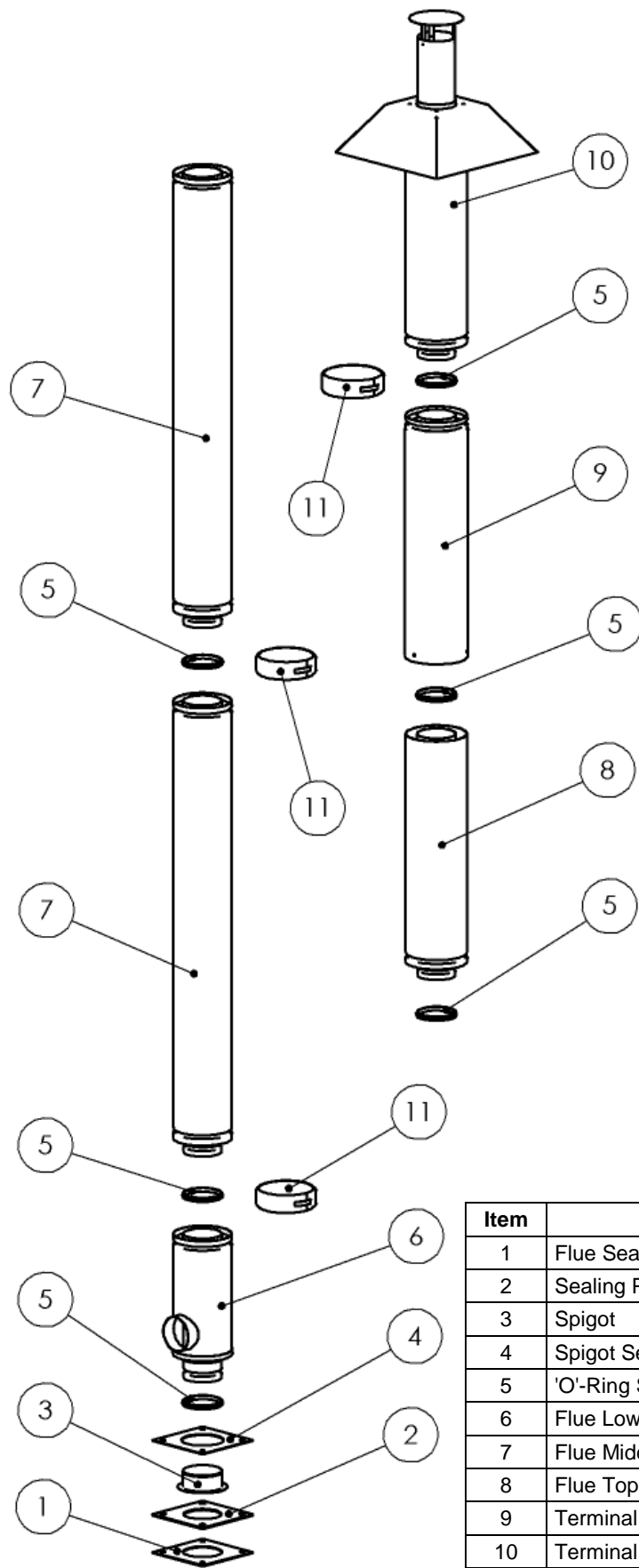

Item	Description	Part No.	Qty
1	Flue Sealing Plate	223191	1
2	Sealing Plate Gasket	223198	1
3	Spigot	222819	1
4	Spigot Sealing Plate	222825	1
5	'O'-Ring Seal	221647	6
6	Flue Lower Section	222820	1
7	Flue Middle Section	222829	2
8	Flue Top Section	222877	1
9	Terminal Lower Section	222880	1
10	Terminal	222850	1
11	Internal Clamping Strap	222899	3
12	External Clamping Strap	222894	1
13	Ceiling Plate (not shown)	208583	2

FIG. 23

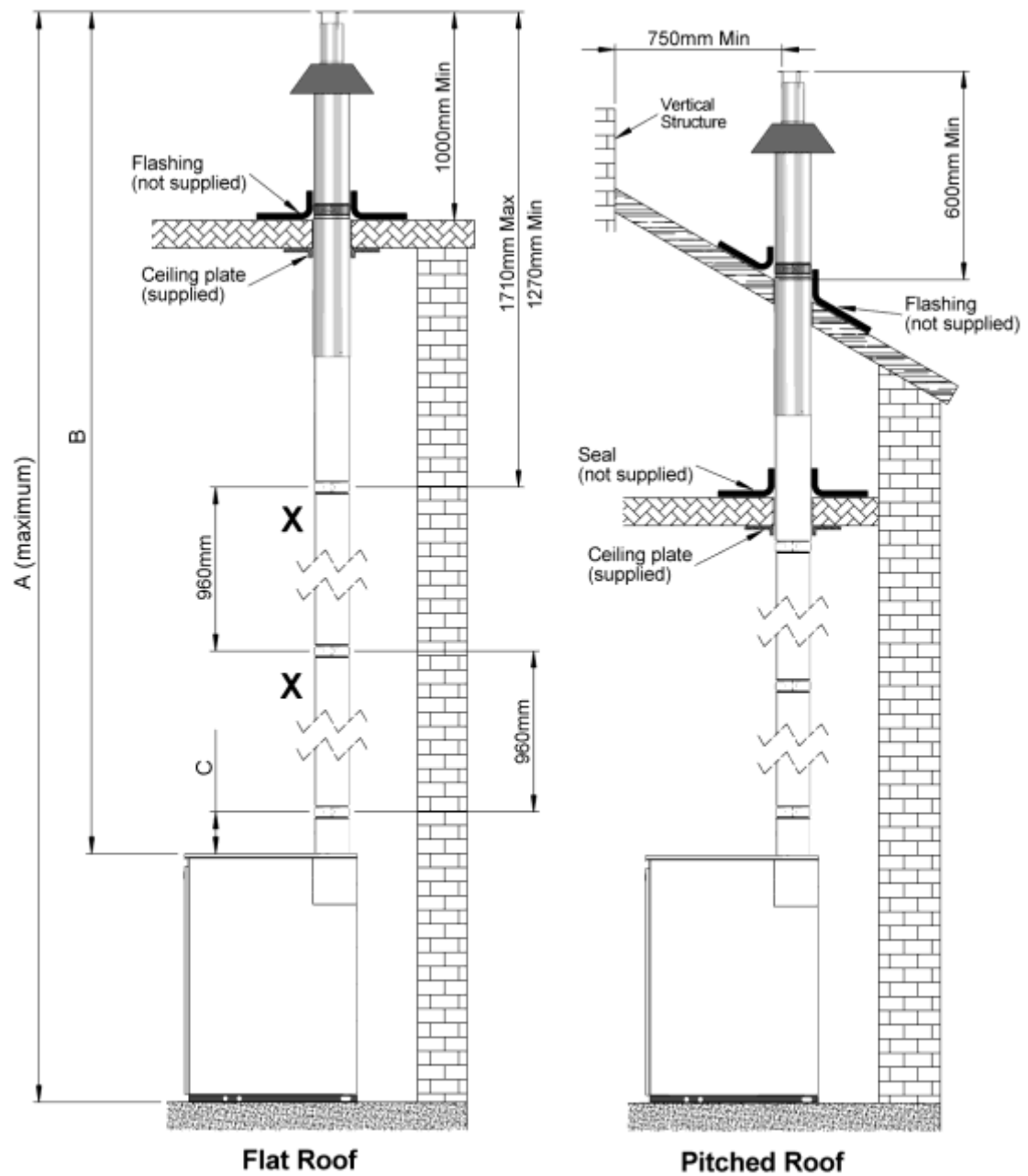

	A	B		C
		Min	Max	
15–20	4600	1390	3750	120
20–26	4600	1390	3750	120
29–36	4650	1398	3758	128

Note 'X': Shorter flue runs can be achieved by discarding the marked sections. Longer runs can be achieved by purchasing additional sections of pipe. Permanent obstructions may be avoided by the use of 45° elbows. See **page 26** for details.

FIG. 24

Extensions and elbows

When fitting the high-level adaptor kit (2357) or the vertical flue kit (2360), combinations of the following items can be used to create alternative configurations:

- 2361 - 500mm short flue extension
- 2362 - 960mm flue extension
- 2363 - 45° elbow

These items should be used to divert or extend vertical sections only. Each is supplied with its own clamping strap and 'o'-ring.

For outputs 15–26 kW, the total flue run must not exceed 6000mm. For outputs 29–36 kW, the total flue run must not exceed 4000mm. Any 45° elbows contribute 500mm each to the calculation. The 90° bend in the vertical balanced flue kit contributes 1000mm.

The 45° elbows can be used to offset the vertical sections of flue on both the high-level and vertical flue kits (**fig 25**). Ensure all 'o'-ring seals are in position and well-lubricated; push the elbow and flue pipe firmly together, securing with the clamping strap provided, securing with the clamping strap provided. The extension pieces (2361 and 2362) can be used between the elbows to extend the diagonal run.

Example:

2 x 45° elbows to offset vertical flue extensions.

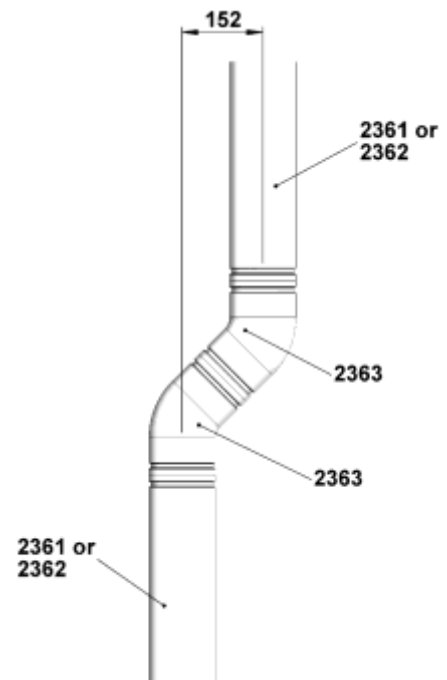
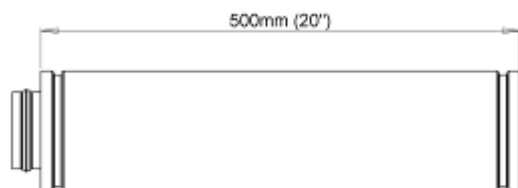
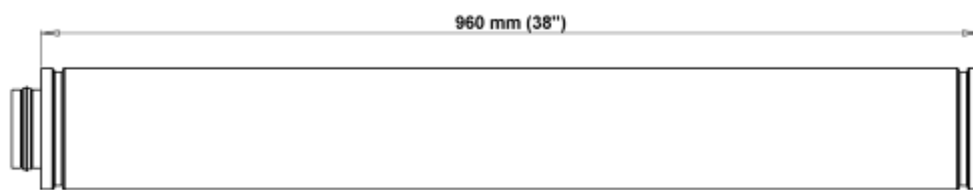

FIG. 25



2361



2362

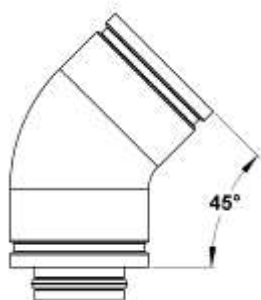

2363

These items are only to be used with the vertical sections of the high-level adaptor kit (2357) and the vertical flue kit (2360).

Each item is supplied complete with its own clamping strap and 'o'-ring.

FIG. 26

COMMISSIONING

Although all burners are tested before despatch, individual site conditions such as oil supply pressures and deviations in the draught mean that the burner will require adjustment after installation to achieve optimal performance. As such, the boiler **must** be commissioned by qualified engineer, preferably OFTEC trained and registered. See the burner setup leaflet for further information.

It is the responsibility of the installation engineer to ensure the boiler is commissioned. Failure to do so will invalidate the guarantee and any extended warranty.

Procedure

- Switch off the electrical supply to the boiler.
- Ensure the boiler is full of water and that all isolation valves are open.
- Remove the combustion chamber access cover and check the baffle positions (**figs 29 & 30**).
- For single-pipe oil supplies, disconnect the supply line from the burner. Open the shut-off valve and run a small quantity of oil into a container to ensure it is clean and free of air. Reconnect the oil supply.
- Check that the programmer is in the **ON** position and that any thermostats are calling for heat.
- Switch on the electrical supply to the boiler, which should now fire.

Note: upon first firing, the burner may lockout due to the retention of air in the oil pump. Should this occur, wait for one minute before pressing the reset button. Should the burner lockout again, the air can be bled from the oil pump via the pressure gauge connection.

- Start and stop the burner several times. When the flame cuts off sharply, this indicates that the remaining air has been dispersed.
- Set the pump pressure to the correct level. Run the boiler for 15 minutes and measure CO₂ levels at the flue gas sample port (**page 28**). Compare the readings with those given in the burner setup leaflet and if necessary adjust the intake of air into the burner.
- Check the smoke number and flue gas temperature.
- If the boiler is not going to be put to immediate use, isolate the oil and electrical supplies. If the boiler is not going to be run during freezing conditions, the system should be drained of water.

Handing over

After completing the boiler installation, the engineer should check the system to ensure it is satisfactory and works according to these instructions. The use of the boiler and other system controls should be demonstrated to the end user.

All instructions should be handed to the user for retention. Advice should be given on the requirement

for an annual service. For householder reference, the form on **page 35** should be completed.

A CD/10 installation completion form (or non OFTEC equivalent) should be completed and a copy left with the end-user. The registration card should be completed in full and returned to TR Engineering. Failure to do so may delay any subsequent warranty work.

All installations must be registered with the local authority's Building Control, either through OFTEC or directly through Building Control. **This is a legal requirement.** After registration, the local council will issue a Works Notification Certificate.

SERVICING

To maintain the boiler's high thermal efficiency and to ensure continued, reliable operation the boiler **must** be serviced annually by a qualified engineer, preferably OFTEC trained and registered. Any electrical work should be carried out by a suitably qualified engineer.

A CD/11 commissioning form (or non-OFTEC equivalent) should be completed and a copy left with the end-user. The CD/11 enables the engineer to demonstrate compliance with building, health and safety, and efficiency requirements.

If the boiler provides central heating and hot water all year round, the best time for the annual service is just before the start of the heating season.

Before starting the service, review the health and safety information on **page ii**.

Pre-service checks

- Ensure the air inlets on the flue terminal are clear.
- Ensure the external controls are working.
- Ensure the ventilation openings are clear and adequate for the size of the boiler (**pages 10–11**).
- Ensure all water and oil connections are secure.
- Inspect the flexible oil lines; replace if necessary.

Oil tank and line filters

- Open the tanks drain cock and draw off any accumulated water and sludge.
- Turn off the oil supply. Remove the filter bowl and clean the filter element with kerosene.

Condensing system

The secondary heat exchanger and condensate trap must be inspected and cleaned as part of the annual service schedule. The secondary heat exchanger is built into the boiler and can only be accessed for cleaning from the combustion chamber access cover. See **fig 27**.

- Remove the combustion chamber cover and remove each of the baffle strips from the flue-ways.
- Clean the baffle strips. The flue-ways can be cleaned using a wire brush before vacuuming any remaining deposits.
- Remove the cleaning port plug from the top of the boiler and clean within using a wire brush or similar.
- Check the condensate drainage system is not blocked and retains a small quantity of water. If the trap requires refilling, pour a small amount of water into the cleaning port. The trap will have sufficient water when water emerges from the drainage pipe.
- Replace the baffle strips, ensuring each is firmly pushed into the flue-ways. See **figs 28 & 29**.

Burner and combustion chamber

- Ensure the electrical supply is switched off and remove the burner. If the boiler uses a balanced flue, remove the air hose first.
- Remove the main combustion chamber baffles.
- Using a wire brush, clean all carbon deposits from the baffles and the internal surfaces of the combustion chamber. Vacuum any remaining deposits from the floor of the chamber.
- Check the flue sealing gasket and the combustion chamber cover gasket; replace if necessary.
- Replace the baffles in the correct order. Failure to do so will impede the correct operation of the boiler. See **figs 28 & 29** for correct placement.
- Replace the combustion chamber cover, ensuring a gas-tight seal is formed.
- Replace the burner nozzle (see the burner setup leaflet for method).
- Refit the burner and air hose (if removed).
- Ensure the system is full of water and switch on the electrical supply. If the system controls are calling for heat; the burner should now fire.
- Check the combustion settings against those in the burner setup leaflet. Adjust the air intake levels and oil pressure as necessary.

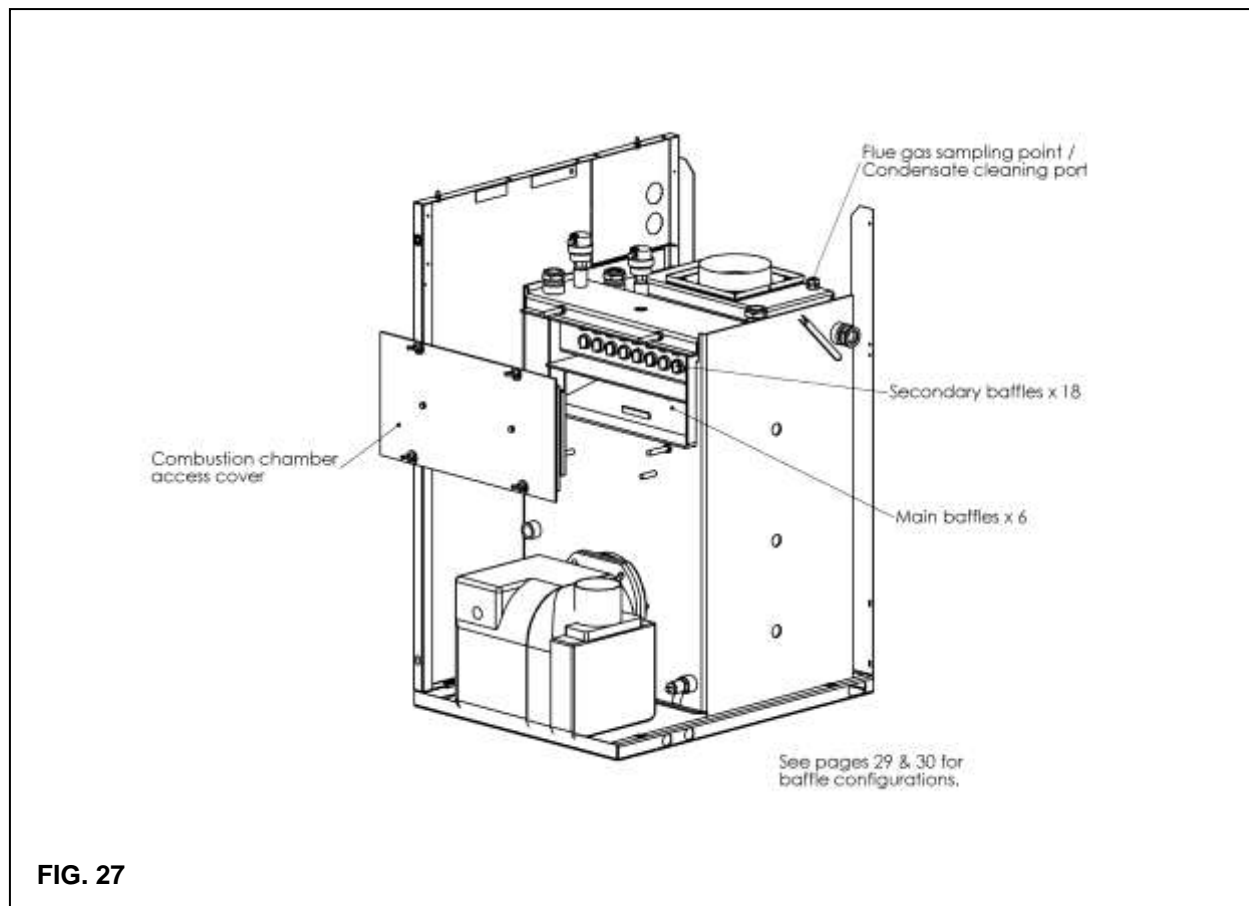

Baffle Configurations (15/20 kW & 20/26kW)
Main Baffles

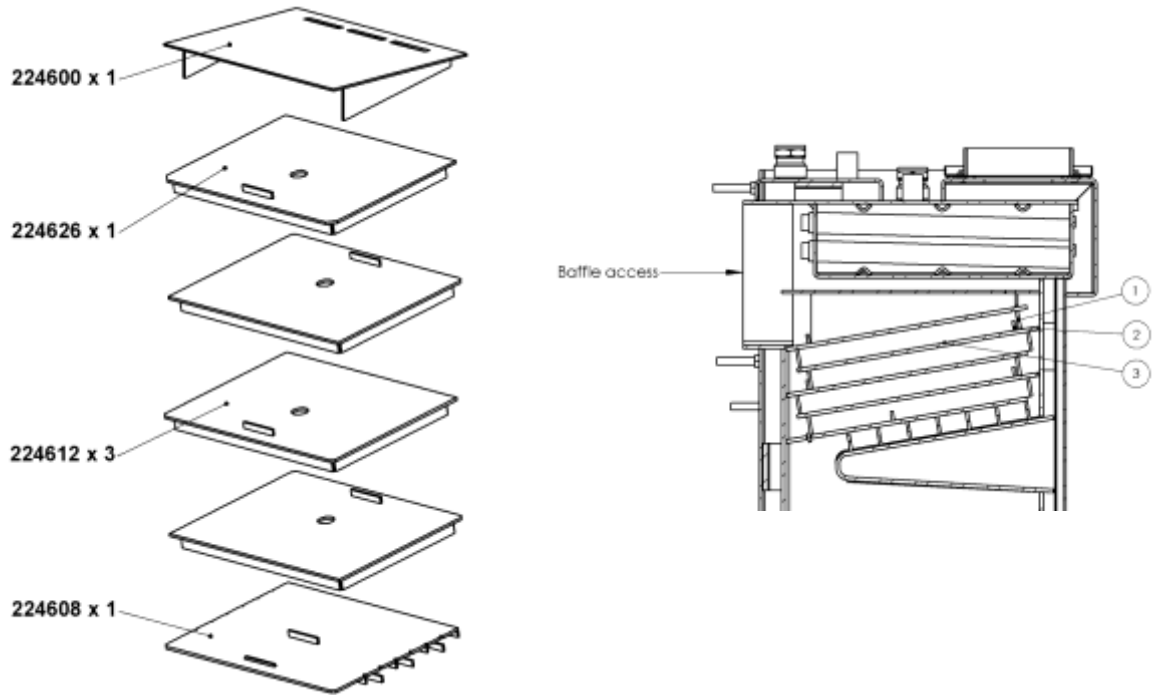

Important: As shown above, the 'skirt' (1) on the underside of each baffle must be hooked over the rear of the lug (2) on the baffle immediately below. The use of a tool may be required to lift the third baffle (3) from the combustion chamber. Insert a screwdriver or similar into the lifting hole in the centre of the baffle and raise above the lip of the baffle access channel. Failure to ensure the correct placement of the baffles will result in incorrect combustion and may invalidate the appliance warranty.

Secondary Baffles

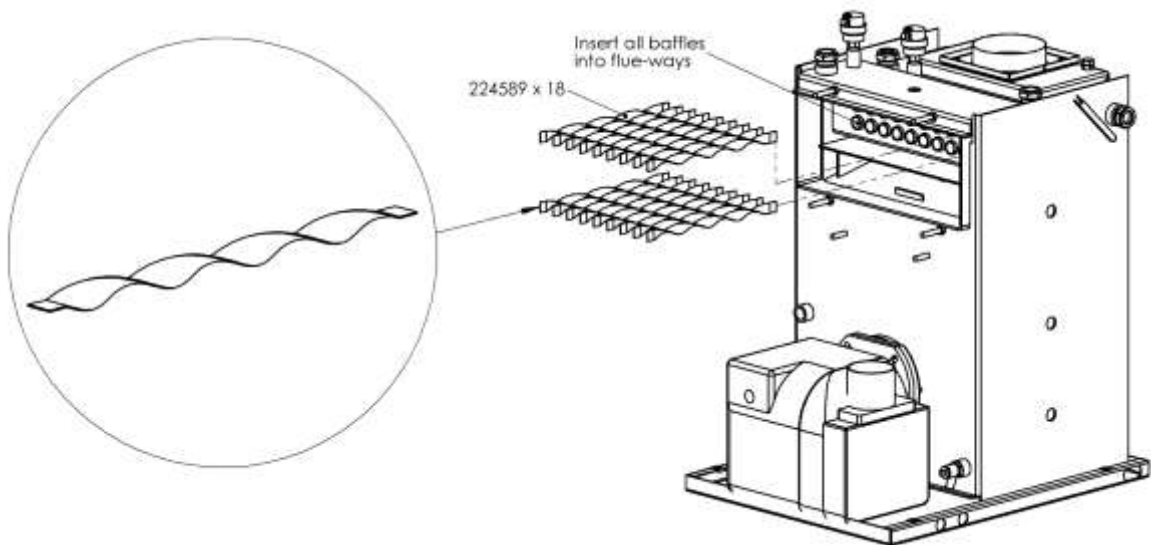
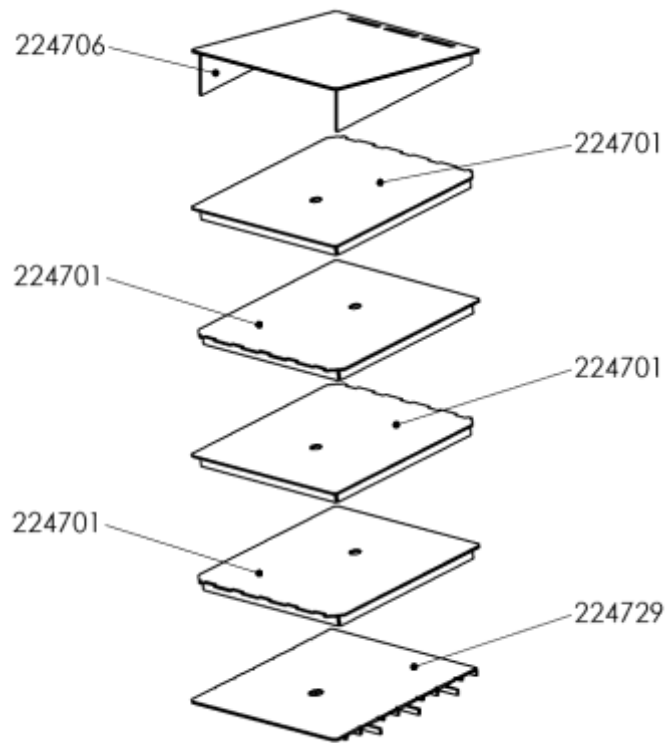

FIG. 28

Baffle Configurations (29/36 kW) Main Baffles



Important: Failure to ensure the correct placement of baffles will result in incorrect combustion and may invalidate the appliance warranty.

Secondary Baffles

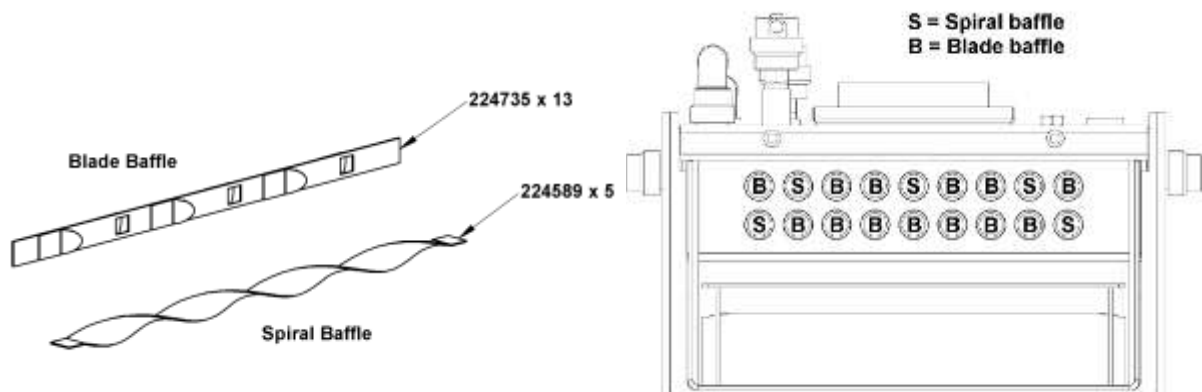

Correct placement of the secondary baffles is **crucial** to the boiler's efficient operation. Turn the baffles so the ends are rotated vertically, and insert into the appropriate flue-ways, as shown opposite.

FIG. 29

BURNER FAULT FINDING

Note: before making any electrical checks or modifications, ensure the mains supply to the boilers is switched off.

Fault	Possible cause	Action
Burner will not start	Control box locked out High limit thermostat tripped System controls satisfied Blown fuse Motor or pump seized	Press red reset button on burner Press red reset button on rear of control panel; check function of boiler thermostat Ensure that all controls are calling for heat Fit new fuse (5A); if problem persists, look for short circuits in the wiring Check for rotation; replace as necessary
Burner starts but flame will not establish	No oil supply Air trapped in pump or oil line Solenoid coil not opening Blocked nozzle Electrodes incorrectly set Electrode insulation cracked Faulty ignition leads Low oil pressure	Check oil levels in storage tank; check for adequate flow through the oil supply pipes Bleed excess air from the pump via the pressure gauge connection Check coil for continuity; replace as necessary Replace the nozzle Reset gap and position to dimensions given Replace as necessary Replace as necessary Check pump pressure and adjust to level given
Flame establishes but cuts out after a few seconds	Oil contaminated with water Oil filter partially blocked Faulty photocell or photocell not seeing flame Low oil pressure	Run oil from drain cock at tank until free of water Wash filter clean with kerosene Clean photocell; check for damage; ensure it is fully inserted; replace as necessary Check pump pressure and adjust
Morning start lock-out	Faulty non-return valve or air leak Low voltage to the boiler Incorrect combustion settings Oil in storage tank below level of burner	Replace non-return valve; repair leak Check with electricity supplier to remedy Check combustion under normal running conditions; set air intake and oil pressure Raise tank or fit two-pipe oil supply
Delayed ignition (burner pulsates)	Nozzle partially blocked Low oil pressure Flue blocked or damaged Fan slipping on shaft Pump coupling loose or worn	Replace nozzle Check pump pressure and adjust Check flue; replace/repair as necessary Check fan; replace/repair as necessary Check coupling; replace/repair as necessary
Burner starts violently	Electrodes incorrectly set Electrodes damaged Faulty ignition leads	Reset electrode gap and position to dimensions given in burner details leaflet Replace as necessary Replace as necessary
Burner repeatedly attempts to fire (balanced-flue only)	Exhaust gas in combustion air	Repair/replace leaking flue sections as necessary; check for obstructions close to the terminal
Combustion fumes smell	Combustion chamber access cover not secure Burner incorrectly fitted or gasket damaged Flue incorrectly fitted or gasket damaged	Tighten nuts; replace seal as necessary Tighten burner to boiler; replace seal as necessary Tighten mounting nuts; replace seal as necessary

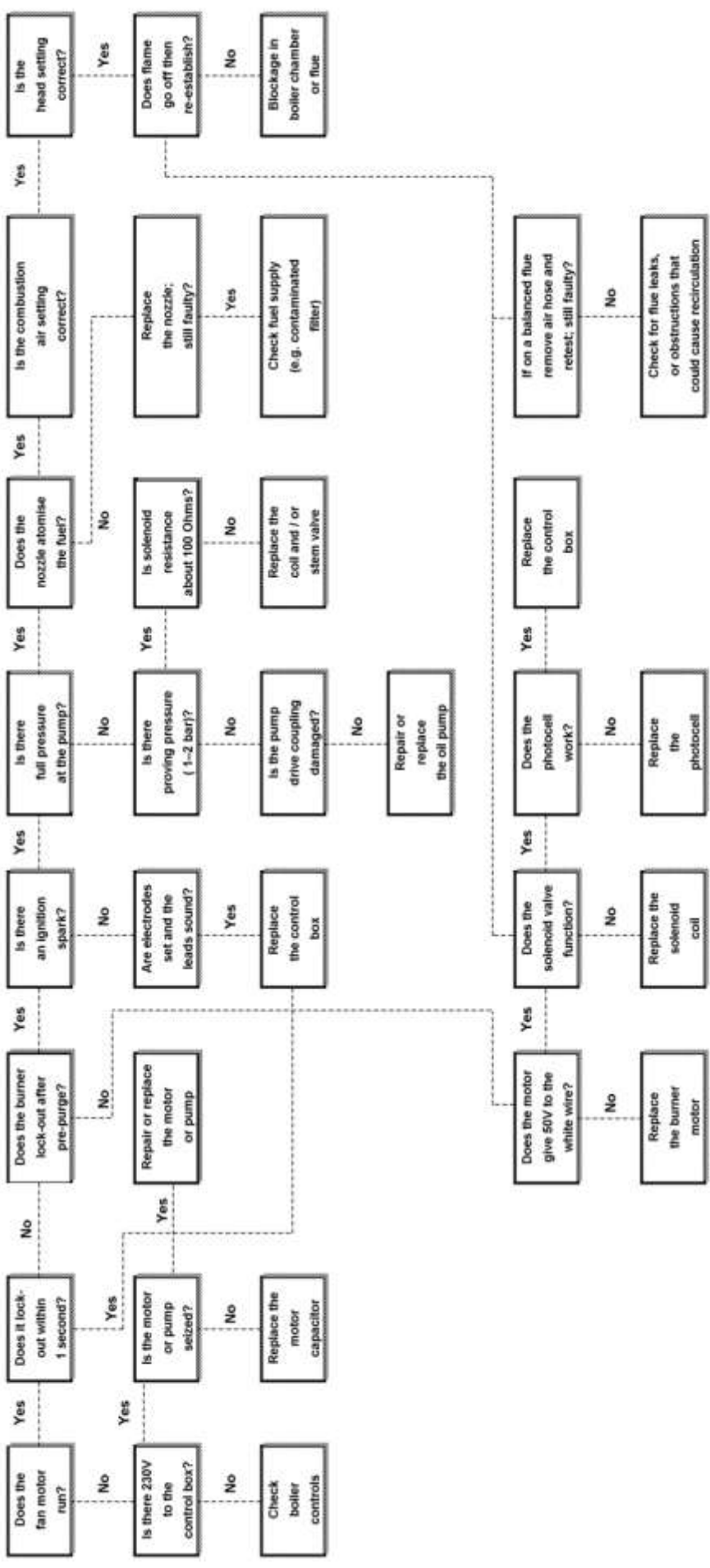

FIG. 30 Burner Fault Finding Logic Chart

SPARES (Fig. 31)

Item	Description	15–26	Qty	29–36	Qty
1	Boiler body	224621	1	224641	1
2	Right panel assembly	224644	1	224711	1
3	Left panel assembly	224647	1	224714	1
4	Top panel assembly	223905	1	223935	1
5	Front door	223917	1	223957	1
6	Back panel	207819	1	207819	1
7	Boiler thermostat	206896	1	206896	1
8	High limit thermostat	206892	1	206896	1
9	Control box assembly	208256	1	208256	1
10	Flue socket	223135	1	223135	1
11	Flue gasket	223071	1	223071	1
12	Top baffle ¹	224600	1	224706	1
13	Second baffle ¹	224626	1	–	–
14	Middle baffle ¹	224612	3	224701	4
15	Bottom baffle ¹	224608	1	224729	1
16	Condensing unit spiral baffle ¹	224589	18	224589	13
16	Condensing unit blade baffle ¹	–	–	224735	5
17	Combustion chamber access cover	224670	1	224690	1
18	Access cover gasket	208151	1	208151	1
19	Burner cover	224810	1	224810	1
20	Burner (15–20 kW)	224820	1	–	–
	Burner (20–26 kW)	224821	1	–	–
21	Burner (29–36 kW)	–	–	224780	1
22	Air intake hose	209491	1	209491	1
23	Burner mounting flange	224781	1	224781	1
	Flange gasket	224782	1	224782	1
24	Burner mounting seal	223108	1	223108	1
25	Condensate drain	224686	1	224686	1
26	Drain cock	99592	1	99592	1
27	Automatic air vent	207296	2	207296	2
28	Flexible oil line ²	224801	1	224801	1

1 Not shown: see fig's 28 & 29 for baffle configurations

2 Not shown: see burner setup leaflet for further information

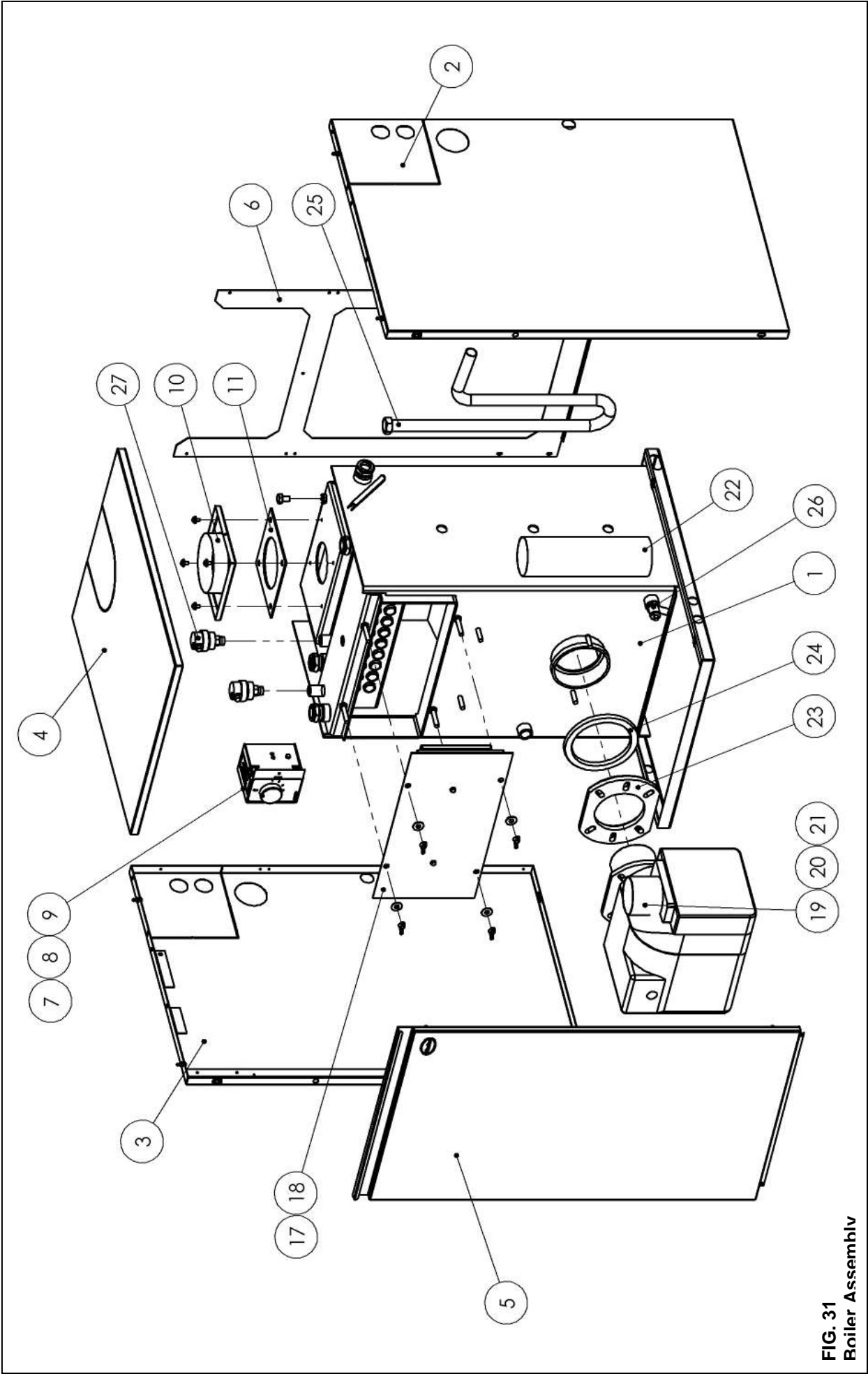

FIG. 31
Boiler Assembly

The following information should be provided upon installation of the appliance for householder reference:

Installation Engineer:
Company:
Company Address:
.....
.....
Company Tel. No:



TR ENGINEERING LTD
Thorncliffe, Chapeltown,
Sheffield, S35 2PH
Tel: (0114) 2572300
Fax: (0114) 2571419
www.trianco.co.uk

Copyright in this brochure and the drawings and illustrations contained within are vested in TR Engineering Ltd
And neither the brochure or any part thereof may be reproduced without prior written consent.

TR Engineering's policy is one of continuous research and development. This may necessitate alterations to this specification
Instructions correct at time of going to print.