



AIR-TO-WATER AIR SOURCE HEAT PUMP S1800 S

USER, INSTALLATION, COMMISSIONING & SERVICING INSTRUCTIONS

**Please read these instructions carefully before installing,
commissioning and using this appliance.**

To be retained by the householder

HEALTH AND SAFETY INFORMATION

INFORMATION FOR THE INSTALLER AND SERVICE ENGINEERS

Under the Consumer Protection Act 1987 and the Health and Safety at Work Act 1974, it is a requirement to provide information on substances hazardous to health (COSHH Regulations 1998).

TR Engineering takes every reasonable care to ensure that these products are designed and constructed to meet these general safety requirements, provided they are properly installed and used.

To fulfil this requirement, products are comprehensively tested and examined before despatch.

When working on the appliance, it is the responsibility of the user/engineer to ensure that any necessary personal protective clothing or equipment is worn appropriate to parts which could be considered hazardous or harmful.

This appliance may contain some of the items below:

Refrigerants

The appliance contains R407c refrigerant. The constituents of R407c are HFC's R32, R125 and R134a, all of which have low toxicity levels.

When handling, avoid inhalation and contact with the skin and eyes. Suitable personal protective equipment must be worn (gloves, overalls, eye protection) and a comprehensive first-aid kit (containing eye wash) should be easily accessible.

Site engineers should have a certificate of competence and should know and understand the properties and hazards before handling liquid refrigerants.

When the appliance has come to the end of its life span, the equipment and refrigerant must be disposed of in accordance with EU law, by an approved engineer.

Seek urgent medical attention if inhaled or ingested. Immediate cleansing of the affected areas and medical attention if necessary should follow exposure to eyes and skin.

Insulation

Fibre insulation may be irritating to the skin, eyes, nose and throat. When handling, avoid inhalation and contact with the eyes. Use disposable gloves, facemasks and eye protection.

After handling, wash hands and other exposed parts. When disposing, reduce dust with water spray and ensure all parts are securely wrapped.

Glues, Sealants and Paints

Glues, sealants and paints are used in this appliance and present no known hazards when used in the manner for which they are intended.



IMPORTANT SAFETY INFORMATION FOR THE END-USER

- Installation of the appliance must only be carried out by persons with suitable engineering qualifications
- Do not attempt to modify, repair or service the appliance yourself
- Do not insert body parts or any other items into the air inlet or air outlet
- Do not start or stop the unit by removing the power cable; always use the controls and switches provided
- Ensure the appliance is protected from prolonged exposure to large quantities of water
- Do not operate the unit or the programmer with wet fingers
- Upon replacement of the fuse, ensure an adequate replacement is used (e.g. not fuse wire)
- Keep the programmer unit out of reach of children
- The electrical supply must be isolated during a heightened risk of lightning strikes
- Do not attempt to move the appliance once installed; this must be carried out by a qualified engineer
- Isolate the electrical supply to the appliance if an odour presents, or scorching is detected
- Only use this appliance for the purpose intended
- Ensure the area around the appliance is clean, well-ventilated and kept free of all obstructions
- Do not keep items on top of the appliance or use it to support other appliances
- Do not under any circumstances stand on the appliance
- Isolate the electrical supply to the appliance if it is to be switched off for a period of more than two weeks
- Drain the water from the water circuit if power to the unit is to be switched off during very cold weather
- Periodically check the condition of any supports for deterioration
- Do not wash the unit with water, alcohol, benzine, thinners, glass cleaner, polish or powders
- During cleaning, isolate the electrical supply to the appliance

The following information should be completed upon installation of the appliance, for householder reference:

Installation Engineer's Signature:
Company Name (if applicable):
Company Address:
.....
.....
.....
Company Tel. No:

Manufacturer's Declaration of Conformity

European Directives Covered by this Declaration:

- EN 55014-1 : 2000 (+A1:2001, A2:2002);
- EN 55014-2: 1997 (+A1:2001);
- EN 61000-3-2 : 2000 (+A2:2005);
- EN 61000-3-3 : 1995 (+A1:2001);
- EN 50366 : 2003;
- EN 14511 : 2004 (parts 1 to 4)

EN 60335-2-40 : 2003 (+A11:2004) used in conjunction with
EN 60335-1:2002 (+A11:2004, A1:2004).

The Basis on Which Conformity is Being Declared

The products identified herein comply with the requirements of the Low Voltage Directive (73/23/EEC) and the EMC Directive (89/336/EEC).

Samples of the product have been tested by the manufacturer and a third-party certification body.

CONTENTS

	PAGE
Health & Safety (Materials)	i
Important End-User Safety Information	ii
Declaration of Conformity	iii
Introduction	6
Operating Instructions	6
Setting the Clock/Timer	6 & 7
Non-timed Control	7
Setting the Water Temperature	7
Operating Parameter Display	8
Safety Cut-out Devices	8
Servicing	8
Simple Fault-Finding	9
Tips for Lowering Energy Usage	9
After-Sales Service Information	10
Technical Information	11
Dimensions & Clearances	11
Water Connection Dimensions	11
Mounting Dimensions	11
Technical Specification	12
Performance Data	12
Installation Instructions	13
Introduction	13
Regulations	13
Siting & Ventilation	13 & 14
Electrical	14
Internal Wiring Diagram	15
Health & Safety	16
Heating & Domestic Hot Water Systems	16
Flushing & Water Treatment	16
Mounting	16
Example System Schematics	17 & 18
Sealed System Components	19
System Filling	20
Commissioning	20
Servicing & Maintenance	20
Operating Parameters & Fault-Finding	21 & 22
Spares	23

INTRODUCTION

Please note, to assist TR Engineering in improving customer service, it is important that the guarantee/registration card is completed and returned.

The Activair is a single component unit air source heat pump, designed to provide hot water or low-temperature heating by extracting heat energy from the surrounding air.

The Activair has been designed and constructed to give years of trouble-free service, and these instructions are provided to assist you in obtaining the best performance with the least trouble and cost.

OPERATING INSTRUCTIONS

The appliance is controlled via the remote programmer included with the unit. This can be situated anywhere in the property, enabling management of the settings without having to access the main unit.

Before starting the appliance, ensure that it has been installed in full accordance with these instructions and that all necessary safety checks have been carried out.

The diagram below (**fig. 1**) shows the programmer layout with the controls uncovered (lift off the protective flap).

SETTING THE CLOCK

Before starting the appliance, the clock should be set to enable control of the heat pump via the timer.

Note: the appliance operates on a 24-hour clock only.

Ensuring the programmer is on standby (LCD screen will not be illuminated), press the **CLOCK** button once. The first pair of digits in the clock display will begin to flash. Press the **CLOCK ADJUSTMENT** buttons (+/-) until the current hour is set.

Press the **CLOCK** button once more; the second pair of digits in the clock display will begin to flash. Press the **CLOCK ADJUSTMENT** buttons (+/-) until the minutes past the hour are set.

To return to standby mode, repeatedly press the **CLOCK** button until the current time is displayed in full.

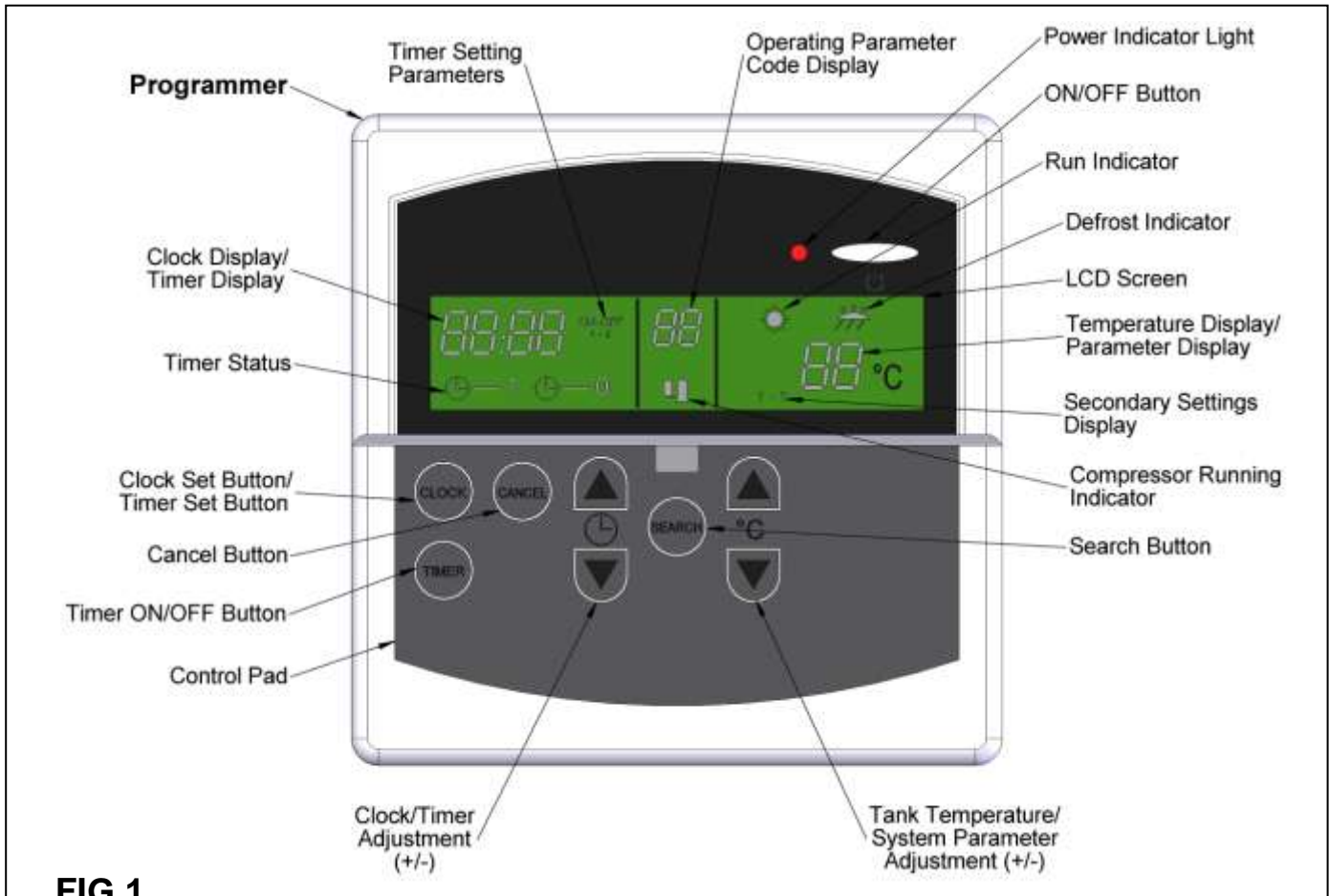

FIG 1

SETTING THE TIMER

Using the timer, it is possible to set two separate time periods at which the appliance will operate.

Ensuring the programmer is on standby (LCD screen will not be illuminated), press the **CLOCK** button three times. The first pair of digits on the clock display will flash and the timer settings display will read 'ON'. The number immediately below this will indicate that programme #1 is currently being modified.

Press the **TIMER ADJUSTMENT** buttons (+/-) until the time is set to the hour you wish the appliance to start.

Press the **CLOCK** button; the second pair of digits in the clock display will begin to flash. Adjust in the same way to set the minutes past the hour.

Press the **CLOCK** button and set the hour you wish the appliance to cease operation. Press the **CLOCK** button once more and set the minutes past the hour.

To return to standby mode, repeatedly press the **CLOCK** button until the current time is displayed. To set a second programme, instead press the **CLOCK** button once.

The first pair of digits on the clock display will flash and the timer setting display will read 'ON'. The number immediately below this will indicate that programme #2 is currently being modified.

Use the **TIMER ADJUSTMENT** buttons (+/-) as described above to set the second programme. After setting the minutes past the hour, press the **CLOCK** button once to return to standby mode.

To activate the programme(s), press the **TIMER ON/OFF** button once. The timer status display will read '1'.

The Activair should now cut in and out according to the times set. The running indicator will display the SUN symbol whenever the appliance is operating.

Please note that during the time periods at which the appliance is set to operate, it will not do so constantly. When the cylinder water temperature has reached the required level, the heat pump will cease operation until the water has cooled or has been used. During these periods, the SUN symbol will flash in the running indicator display.

Please ensure that all other required parameters, such as cylinder water temperature (see adjacent column), have been set before operating the appliance.

To cease operation in this mode, press the **TIMER ON/OFF** button once. The timer status display will read '0' and the appliance will return to non-timed control mode.

NON-TIMED CONTROL

It is possible to operate the appliance without using the timer control. Ensure that the clock and all other required parameters have been set before continuing.

Ensure the timer status display reads '0' and press the **ON/OFF** button at the top right of the programmer. The LCD display and power indicator light will illuminate and the appliance will start. The running indicator will display the SUN symbol whenever the appliance is operating.

The appliance will now run until the required cylinder water temperature is reached, at which time the SUN symbol will flash in the running indicator display.

Please ensure that all other required parameters, such as cylinder water temperature (see below), have been set before operating the appliance.

To cease operation in this mode, press the **ON/OFF** button once. The LCD screen and power indicator light will fade.

SETTING THE WATER TEMPERATURE

The appliance can be set to heat water between a range of 20°C and 55°C, depending upon your preference. The water temperature can be adjusted at any time, whether the heat pump is running or inactive.

To set the cylinder water temperature, press the **TEMPERATURE ADJUSTMENT** buttons (+/-). The temperature display will change accordingly, before returning to displaying the current cylinder water temperature.

When the cylinder water temperature has reached the required level, the appliance will cease to operate until the water in the cylinder has been used or has cooled.

REFRIGERANT PRESSURE GAUGES

The appliance incorporates two refrigerant pressure gauges. The lower gauge displays the refrigerant pressure at low levels (pre-compression); the top gauge displays the refrigerant pressure at high levels (post-compression). The default reading for both when the Activair is idle is 9.6 bar (20°C ambient).

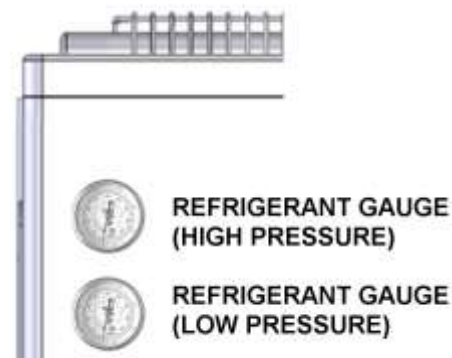

OPERATING INSTRUCTIONS (continued)

OPERATING PARAMETER DISPLAY

In certain circumstances, the unit may enter a temporary lock out mode in order to maintain efficient operation. During such times, a code will appear on the programmer display (**fig. 1**). This is entirely normal and the unit will automatically resume functioning once it has completed its reset cycle.

In the unlikely event the appliance does not resume operation, full descriptions of the operating parameters and their causes can be found on **page 21**.

FROST PROTECTION

As the appliance may be fitted externally to the property being heated, the water in the system may be in danger of freezing in very cold weather. As such, the Activair has frost protection which will bring the heat pump on should the temperature drop too low. However, to provide protection in the event of a power outage, a suitable antifreeze should be added to the system.

DEFROST MODE

If the temperature is cold enough for ice to develop on the coil, this may become clogged and cause the appliance to cease operation. Should this occur, the unit will automatically enter defrost mode. This will divert heat from the heating circuit back to the coil until the ice has melted. The DEFROST symbol will appear above the temperature display (see **fig. 1**) during such times.

PRESSURE SWITCH

Should the refrigerant pressure within the appliance reach too high a level, the unit will automatically switch off until the pressure has been reduced, whereupon the unit will restart automatically. Please note that the unit may take several minutes to restart after the pressure switch has operated.

Refer to the operating parameter descriptions, **page 21**, for further details.

AMBIENT TEMPERATURE CUTOUT

Should the ambient temperature around the appliance reach too high a level, the unit will automatically switch off until the temperature has been reduced, whereupon the unit will restart automatically. Please note, that the unit may take several minutes to restart after the cut-out has operated.

Refer to the operating parameter descriptions, **page 21**, for further details.

COIL TEMPERATURE CUTOUT

Should the coil temperature reach too high a level, the unit will automatically switch off until the temperature has been reduced, whereupon the unit will restart automatically. Please note that the unit may take several minutes to restart after the cut-out has operated.

Refer to the operating parameter descriptions, **page 21**, for further details.

COMPRESSOR OUTLET TEMPERATURE CUTOUT

Should the compressor outlet temperature reach too high a level, the unit will automatically switch off until the temperature has been reduced, whereupon the unit will restart automatically. Please note that the unit may take several minutes to restart after the cut-out has operated.

Refer to the operating parameter descriptions, **page 21**, for further details.

SHUTTING DOWN FOR LONG PERIODS

If power to the heat pump is shut down for a long period during very cold weather, it is advisable to completely drain the system. However, too frequent draining of the system should be avoided, especially in hard water areas, as this could lead to the build-up of scale in any heating circuit.

SERVICING

While it is not necessary to carry out an annual service on the appliance, regular inspections may be required, depending upon where the unit is sited. Full details can be found on **page 20**.

SIMPLE FAULT-FINDING

If the appliance fails to start for no apparent reason, carry out the following checks before referring to the operating parameter and fault-finding guide (**page 22**), or calling your service engineer:

1. The unit may be running through a process to clear an operating parameter condition. In most cases, this will be cleared automatically, though if it persists, check the programmer display (**fig. 1**) for an operating parameter number. Refer to the guide on **page 21** for full descriptions and remedies.
2. Ensure there is a current 'heat demand' from the programmer. Ensure the programmer clock and timer controls have been set in accordance with the instructions on **pages 6/7** or that it is switched on (if in non-timed mode).
3. Check for failure in the electrical supply.
4. Check for a blown fuse. If the fuse has blown and the replacement also fails, switch off the mains electrical supply to the appliance and contact your service engineer.
5. Check the circuit breaker (if fitted). If this has tripped, reset and restart the appliance. If the circuit breaker trips for a second time soon after, switch off the mains electrical supply to the appliance and contact your service engineer.

Note: if the appliance has been shut down due to a failure of the power supply, the programmer contains a battery backup which will allow the preservation of all settings and timings.

If the appliance is operating, but the water temperature is lower than expected:

1. Check that all isolation valves are fully open.
2. Check the water temperature setting is not too low. This can be increased by following the instructions on **page 7**.

3. Check that the vents on the back of the unit and the coil have not become blocked, impeding the air flow.
4. Check the unit has not entered defrost mode (the DEFROST symbol will appear above the temperature display – see **fig. 1**). Should this occur, the heat output from the appliance will be diverted to the coil, until any ice build-up has been removed.
5. Ensure there is no air trapped in either the Activair or the heating/hot water system (**page 20**).

If sounds are heard from the appliance which sound like the passage of water, this is merely the normal movement of the refrigerant within the unit.

If there is power to the appliance and the programmer is providing a 'heat demand' to the unit, yet the unit has not entered running mode (the SUN symbol has not appeared above the temperature display), it may be that one of the safety cut-outs (see **page 8**) has operated. These will typically take several minutes to clear before the unit restarts.

Other Checks

Ensure the default system settings have not been altered. These are accessed by holding in the **SEARCH** button for five seconds when the programmer is switched off. These are factory-set and should not require adjustment.

Setting 1 - Factory-set at **26**.

Setting 2 - Factory-set at **18**.

Setting 3 - Factory-set at **14**.

These settings should not be altered from the above without the express permission of Trianco.

If for some reason the settings do not match the figures given above, alteration is made via the **TEMPERATURE ADJUSTMENT** buttons (+/-).

TIPS FOR IMPROVING PERFORMANCE AND EFFICIENCY

- 1) Unit maintenance has a dramatic impact upon system performance and service life. Ensure regular inspections are carried out over the lifetime of the appliance. Dirty coils and fans reduce airflow through the system, resulting in decreased performance. Regular checks should be carried out to ensure the cleanliness of these components.
- 2) Programme the appliance to operate at times when the surrounding ambient temperature is at its highest (e.g. noon). A thermal store may be employed to allow the retention of hot water at this time for later use.
- 3) If installed externally to the property being heated, the unit should be protected from high winds, as this can lead to reduced airflow and efficiency, and also cause frost problems; though avoid siting in areas where the airflow is too restricted, resulting in recirculation of air over the coil.
- 4) Well-insulate the pipework to and from the appliance to retain as much heat as possible.
- 5) Where possible, subscribe to economy electricity tariffs (contact your electricity supplier for more information).
- 6) Lower temperature settings will reduce the amount of energy consumed by the unit.

AFTER-SALES SERVICE INFORMATION

A qualified field service engineer is available to attend a breakdown or manufacturing fault occurring while the appliance is under guarantee.

The appliance must be made available for service during normal working hours, Monday to Friday.

Please note, upon attendance by a TR Engineering field service engineer, a charge will be made on-site where:

- The field service engineer finds no fault with the appliance
- The cause of a breakdown is due to other parts of the system not manufactured by TR Engineering
- The cause of the breakdown is due to incorrectly fitted spare parts, or third-party spares not designed for specific use with the appliance
- The appliance has not been correctly installed as recommended in these instructions, or by unqualified persons
- The breakdown occurs outside the guarantee period
- The appliance has not been maintained correctly
- The breakdown occurs due to use of the appliance not sanctioned by these instructions
- The breakdown occurs as a direct result of unauthorised third-party work on the appliance

Important:
Invoices for attendance and repair work carried out on this appliance by any third party will not be accepted unless authorised in advance by the TR Engineering service centre.

TECHNICAL ASSISTANCE

A team of trained technical advisors are available to discuss any problem with the appliance which may occur. In many cases, the problem may be solved over the telephone, eliminating the need for a service visit.

HOW TO REPORT A FAULT

Step 1:

Contact your installer or service engineer, who should thoroughly check all recent work before the attendance of our field service engineer is requested.

Step 2:

Contact the TR Engineering service centre for assistance. Please make a note of any operating parameter codes, which appear, on the programmer display before making contact.

If your own installer/service engineer is unavailable, contact the TR Engineering service centre. Please be aware that a charge may be made for any visit not covered by the appliance guarantee.

Before contacting either the TR Engineering service centre or the technical advice line, please have the following information ready:

- 1) Appliance serial number or your unique customer identification number (issued upon registration of the appliance with TR Engineering)
- 2) TR Engineering
- 3) Description of fault, including any operating parameter code which may be displayed on the programmer
- 4) Date of installation

Appliance Serial No.: _____
Cust. ID No.: _____
Installation Date: ____/____/____
Corrosion Inhibitor Fitted: Yes: ____ No: ____

SERVICE CENTRE AND TECHNICAL SUPPORT

Tel: 0114 257 2300 Fax: 0114 257 1419

Hours of Business

Monday – Thursday: 8:30am – 17:00pm
Friday: 8:30am – 14:30pm

TECHNICAL INFORMATION

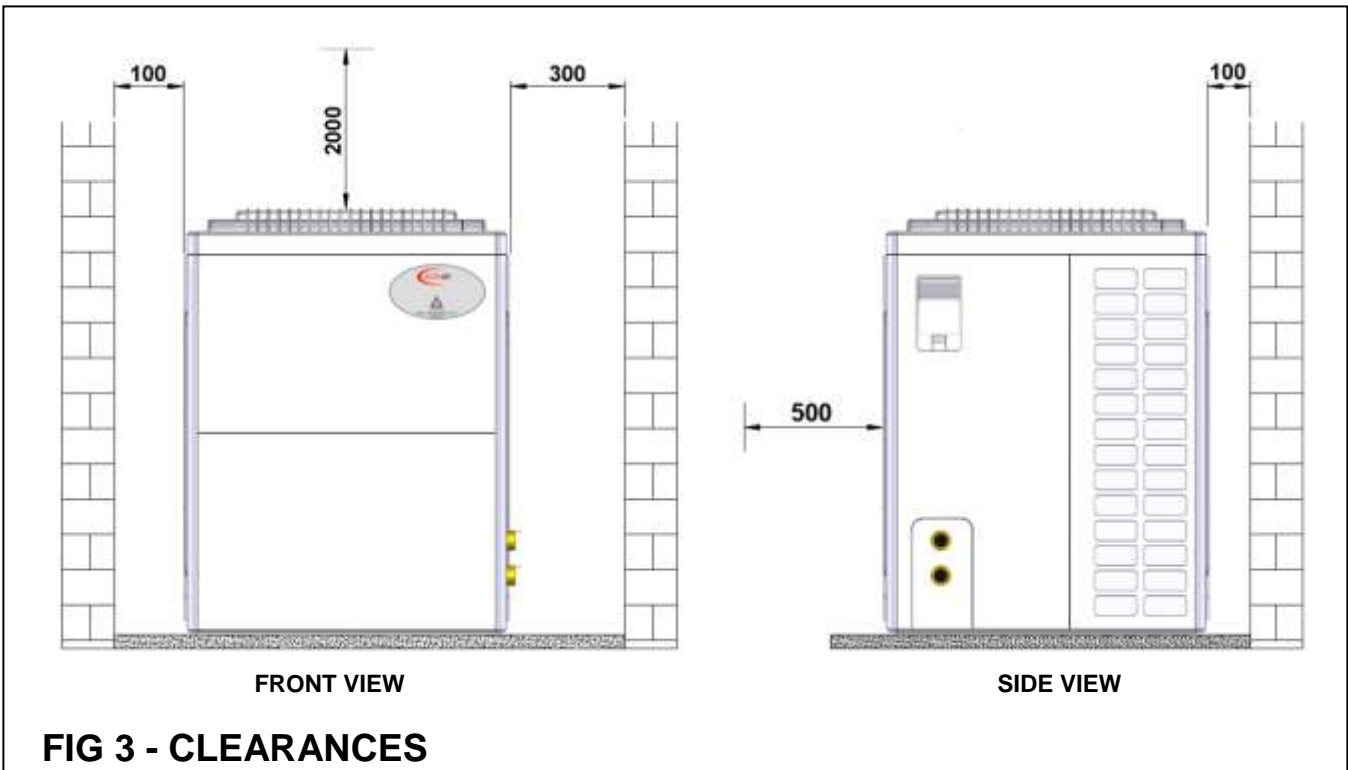
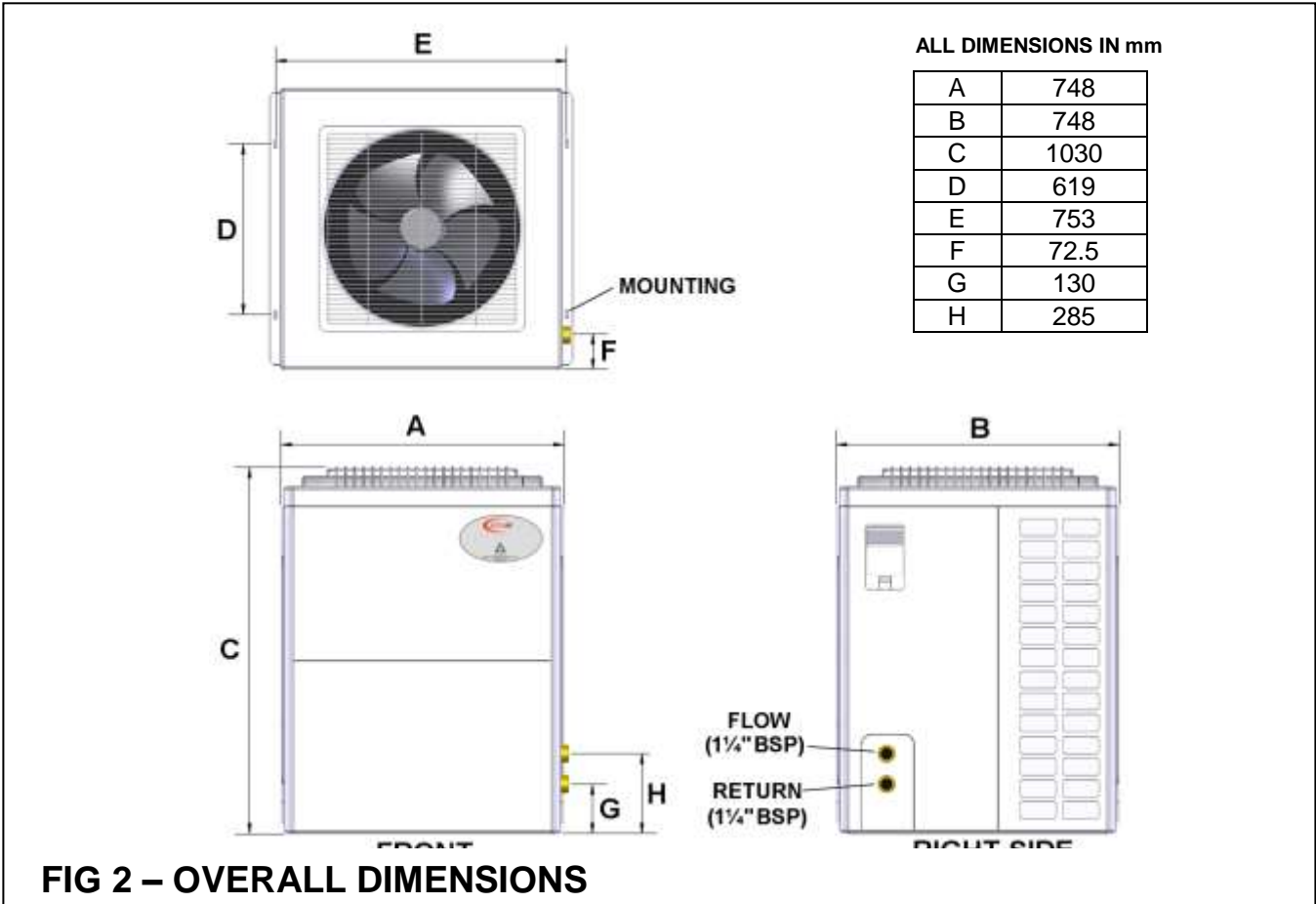

TECHNICAL SPECIFICATION

Output / Ambient	See graph below
Max. Input Power	6.5kW
Max. Input Current	29 amp
Cable Size	6mm
Required Flow Rate (primary water)	70 litres/min
Weight (empty)	150kg
Noise Level	60 dB(A)
Min. Water Output Temperature	20°C
Max. Water Output Temperature	55°C
Power Supply	230V - 50Hz Fused at 32 amp
Working Ambient Temperature Range	-5°C to 43°C
Flow & Return Connections	1¼" BSP
Refrigerant	R407c (4.2kg)
Refrigerant Pressure (20°C ambient)	9.6 bar (idle)
Electrical Shock Protection	1
Water Protection	IPX4
Casing Finish	White

HEATING PERFORMANCE

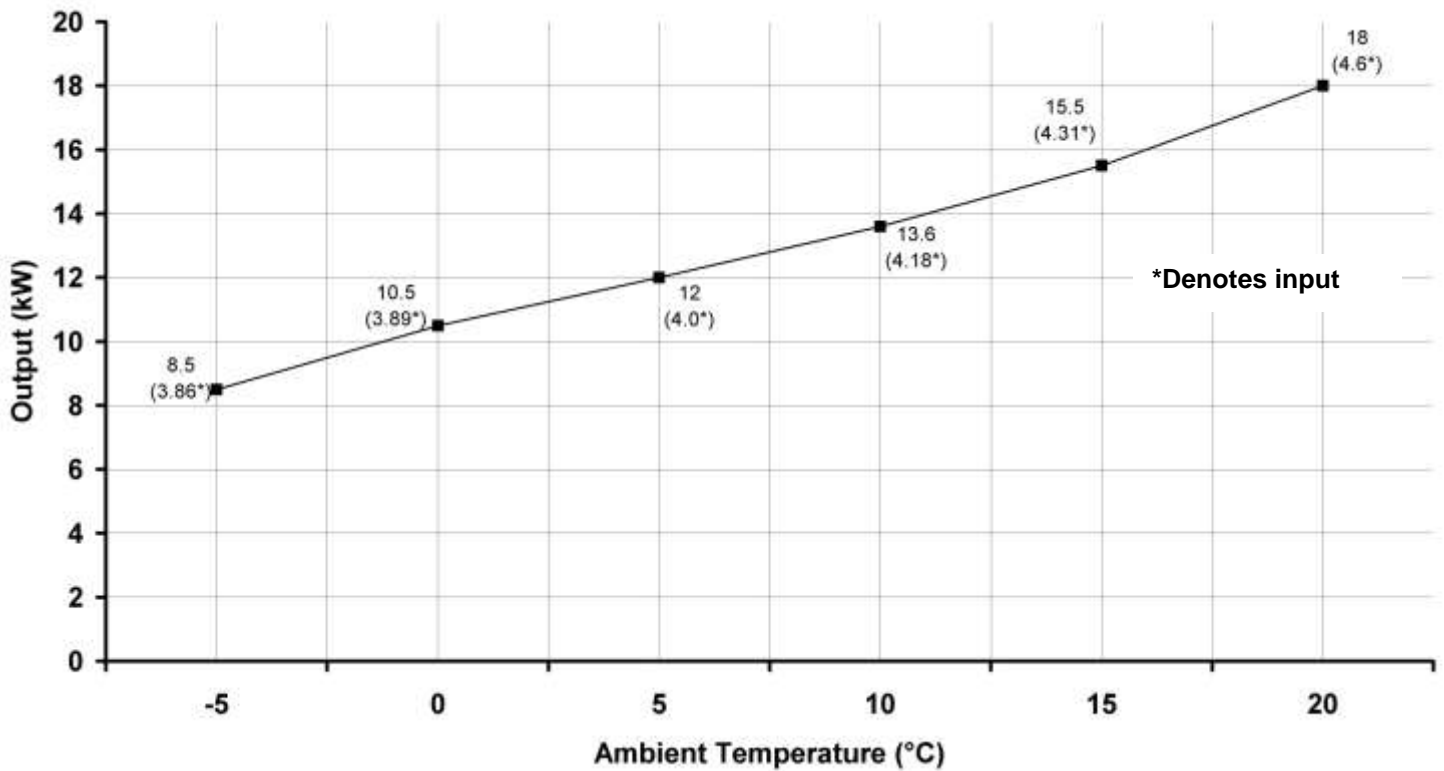

INSTALLATION

INTRODUCTION

The Activair air source heat pump must be installed in full accordance with these instructions and all relevant standards.

Installation must be carried out by a fully qualified engineer. All specialised work (e.g. electrical and handling of refrigerants), must be carried out by suitably qualified individuals.

All heat pumps are provided charged with refrigerant and are fully tested and programmed, requiring only connection to a suitable wet system, a suitable electrical supply and the setting of the clock parameters and required water temperature.

The Activair operates best with well-insulated buildings which comply with current Building Regulations (Part L).

The unit utilises R407c refrigerant.

REGULATIONS

These installation notes are for guidance only, and should be superseded by any national or local regulations which may apply.

Installation of the appliance must comply with BS 15450 Design of Heat Pump Heating Systems, and all other relevant British Standards and Regulations, Building Regulations, current I.E.E. Regulations, and the Local Water Undertakings Bylaws.

HEALTH AND SAFETY

Health and Safety at Work Act

The installer should be aware of his responsibilities under the Act and provide, where necessary, appropriate protection for all persons carrying out the installation

Lifting

The appliance may require two persons, or specialised lifting equipment, to lift into position. Ensure all lifting equipment is fully approved and checked for safety before use.

Do not under any circumstances stand on the appliance.

SITING & VENTILATION

Important note: if the unit has been moved significantly from an upright position prior to installation, it must be left standing for at least 24 hours before use.

The Activair can be fitted either internally or externally to the property being heated.

The appliance must be installed in a clean, well-ventilated area which is free of all obstructions. Please ensure enough space is left around the unit to enable access for routine inspections.

See **page 11, fig. 3** for appropriate clearance dimensions. Failure to ensure adequate clearances may hinder correct and efficient operation of the unit.

Please note that the appliance may have to be moved in order to gain access to some of the serviceable items from the rear.

The appliance should not be boxed-in, as the movement of free air is vital to the correct operation of the appliance.

Do not install the appliance in areas which have a potential for gas leakage or with a high concentration of salts, oils, soot and sulphur.

Do not install the appliance on a moving vehicle (e.g. a ship or barge).

If the unit is installed outside, ensure it is adequately protected from prolonged exposure to large quantities of water. **Note:** the unit is designed to operate normally in wet conditions.

It is preferable, though not essential, that the unit is sited in a position that receives maximum sunlight.

The appliance controls should always be sited within the property.

The appliance should only be installed on a sturdy base, which is level and capable of supporting the installed weight of the unit, including its full water content. The base should be firm enough to prevent vibration.

The use of vibration pads is recommended to prevent excess vibration and noise transmission.

To obtain the best performance from the S1800S it is recommended that the unit be sited externally to the property being heated.

Do not site above doorways or other openings.



SITING AND VENTILATION (continued)

Do not install the appliance within 1000mm of television, radio or stereo equipment.

The appliance should not be installed where it will be exposed to unusually high wind speeds.

Sound Levels

Whilst the low sound levels of the appliance makes it suitable for siting externally and internally, the following factors should be taken into consideration before installation:

- a) Some people are particularly sensitive to low noise levels – discuss with the end-user and site in a place where the least nuisance would be caused to neighbours. If in doubt, contact the local council. If necessary, construct an acoustic barrier.
- b) Small rooms tend to amplify noise, particularly if the room construction is hollow or the surface tiled.

MOUNTING

The appliance should be screwed firmly to a sturdy base via the mounting feet on the underside of the unit. The base should be level and capable of supporting the installed weight of the unit, including its full water content. The base should be firm enough to prevent vibration.

INTERNAL INSTALLATION

Ensure adequate clearances are in place to enable the heat pump to pass through any entrances (see **page 11, fig 2** for unit dimensions). Ensure adequate provisions are in place for maintenance and potential removal of the heat pump at a future date. The room must be well insulated.

Ventilation/Air Flow

Inadequate airflow over the coil may result in reduced performance. The airflow requirement is 1175 cubic feet per minute. If adequate airflow cannot be achieved, ventilation from the outside may be required.

PUMP CHOICE AND FLOW RATE

Please note that a 15/50 or 15/60 pump will not be suitable to achieve the minimum flow rate required.

Failure to achieve the flow rate can cause serious damage to the appliance and will invalidate the warranty. (see page 12 for required flow rate)

ELECTRICAL

230V single-phase 50Hz (fused 32 amp).

Electrical work should be carried out in accordance with BS 7671:2001, current I.E.E. regulations and any local regulations which may apply, by a qualified electrical engineer.

Important: isolate the electrical supply before accessing the inside of the appliance.

This appliance must be earthed and the earth cable must be of a greater length than the current-carrying conductor cables (i.e. live and neutral supply cables).

Connection to the appliance should be hard-wired to the consumer unit.

The minimum supply cable size is 6mm

In the event of a fault after installation, the electrical system should be thoroughly checked for fuse failure, short circuits, incorrect polarity, resistance to earth, and earth continuity.

In certain areas of the country, where there is a known risk of high or low voltage fluctuations, the appliance should be prevented from starting by the use of a voltage-sensitive device if the voltage drops or increases sufficiently to endanger the installation.

The programmer is connected to the unit via the plug supplied with the appliance.

If the supply cord is damaged, it must be replaced by the manufacturer, its service agent or similar, for one of the same specification as that fitted.

See **fig. 4** for internal wiring details.

PUMP AND WATER FLOW SWITCH WIRING

The pump should be wired into the appliance as shown on the wiring diagram opposite (into terminals **4** (live) and **N** (neutral)). A water flow switch can be fitted to terminals **SL** and **PCOM**. Should a water flow switch not be fitted, these must be linked.

BACKUP WIRING

A backup system, such as an inline boiler or an immersion heater, can be controlled by the Activaire by wiring controls into terminals **3** (live) and **N** (neutral). This will cause the backup to operate should the ambient temperature around the Activaire drop to 0°C or below. Alternatively, a separate low-temperature thermostat can be used.

NOTE: Any backup should have its own independent power supply. The Activaire is providing a switched live only.

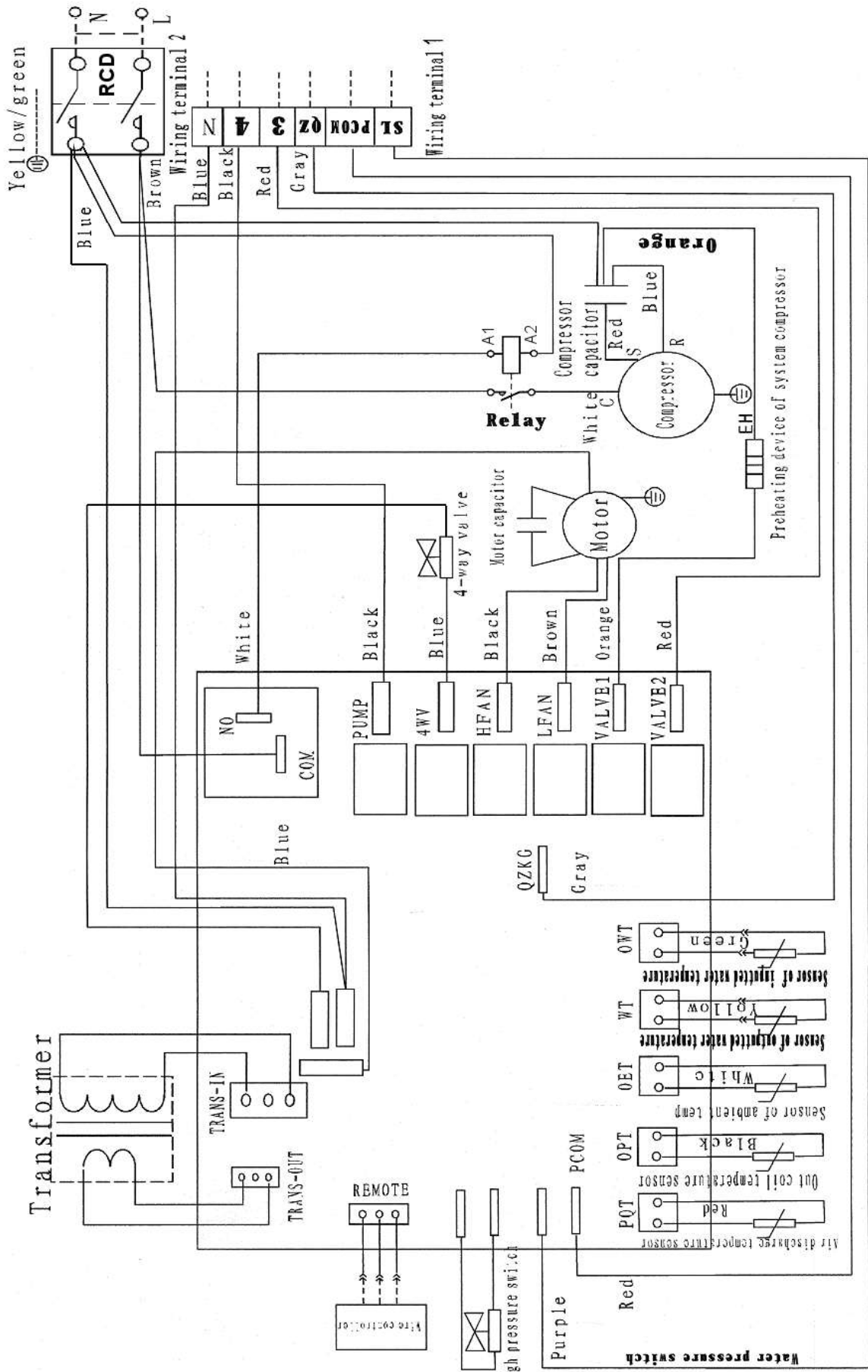

FIG 4 – INTERNAL WIRING DIAGRAM

INSTALLATION (continued)

DOMESTIC HOT WATER AND HEATING SYSTEMS

Heating systems must be installed in accordance with HVCA Codes of Practice and BS 5449 Part 1.

The flow and return water connections are made on the right side of the unit. Flexible connectors must be fitted to the flow and return tapplings to prevent vibration to the pipework. Refer to **fig. 2** for pipework dimensions.

Isolation valves must be fitted on the flow and return pipework close to the appliance, for ease of disconnection and servicing. On sealed systems, a 3 bar pressure relief valve must be situated between the heat pump and the first isolation valve on the return side. The system should be fitted with an automatic air vent.

Some typical DHW and central heating system schematics are shown on **figs. 5-10** overleaf. See **page 20** for filling instructions.

It is strongly recommended that 35mm diameter pipework is used. This will help to ensure an appropriate flow of water through the system.

All pipework should be insulated in accordance with the relevant Building Regulations. All pipework external to the property should be kept to a minimum, and **must** be insulated.

FLUSHING AND WATER TREATMENT

The performance of the appliance could be impaired by system debris or the effects of corrosion. New systems must be thoroughly flushed to remove metal filings, solder, machining oils and any other fluxes or greases before connecting the unit.

When fitting the appliance to an existing system, it is advisable to clean the system by using an appropriate flushing and descaling agent. Refer to BS 7593 [1992] for guidance. System additives – antifreeze, corrosion inhibitors and all flushing agents/descalers should be suitable for this type of appliance. Always refer to manufacturers' instructions.

Failure to flush and add inhibitors to the system may invalidate the appliance warranty. The appliance must not be run without water in the system.

HEATING PERFORMANCE

The Activair provides hot water and heating by extracting ambient heat energy from the surrounding air. Therefore, in lower temperature conditions, the output of the unit will be reduced. **All hot water system, cylinder, central heating and underfloor heating sizing calculations must take this into account.** A chart of Activair heat outputs at various ambient air temperatures can be found on **page 12**. Should a backup system be required, such as an immersion heater or inline boiler, this can be controlled by the Activair. See **page 14** for wiring details.

CYLINDER AND UNIT SIZING

The size of the cylinder to be used in conjunction with the appliance is determined by the type of cylinder fitted. Modern cylinders will provide details on heat-up times based upon a particular heat input. A cylinder sized to the requirements of the end user can then be selected.

Alternatively, approximate cylinder recovery times can be calculated using the following formula:

$$\frac{\text{(Cylinder size (litres) x 1.16 x required temperature rise)}}{1000}$$

This will return the kW input required for the cylinder to fully heat up in one hour.

Example

The following example calculation is based upon a 100-litre cylinder and a required temperature rise of 40°C (from 15°C to 55°C):

$$100 \times 1.16 = 116$$

$$116 \times 40 = 4640$$

$$4640 / 1000 = 4.64\text{kW}$$

This is the kW input required to heat the cylinder in one hour. Therefore, an Activair unit running at a 12kW output would heat the cylinder in 23 minutes.

Please note that some differences may apply depending upon the age and type of cylinder used.

CENTRAL HEATING

If required, the Activair can provide low-temperature comfort heating. The maximum water temperature from the appliance is 55°C. As such, radiators should be sized approximately 33% larger than would otherwise be recommended for more conventional forms of heating. Alternatively, instruct the end user to programme the heating to come on earlier than with conventional heating, or use double-panelled radiators.

The use of a thermal store (buffer tank) is required in order to maintain correct water flow rates. The store may be a direct or indirect cylinder. See **figs 5-10** for some example system schematics.

UNDERFLOOR HEATING

The use of a thermal store is **required** in order to properly regulate the flow of water through the system. It will also help to prevent short cycling, improving the efficiency of the unit. The store may be a direct or indirect cylinder. See **figs 5-10** for some example system schematics. See **page 19** for buffer tank sizing directions.

SYSTEM SCHEMATICS

The Activaire is suitable for connection to standard sealed systems and open vent systems. The following example schematics are for reference only. All systems must be installed in compliance with current Building Regulations and any local directives which may apply.

Note: a circulating pump is not included within the Activaire unit.

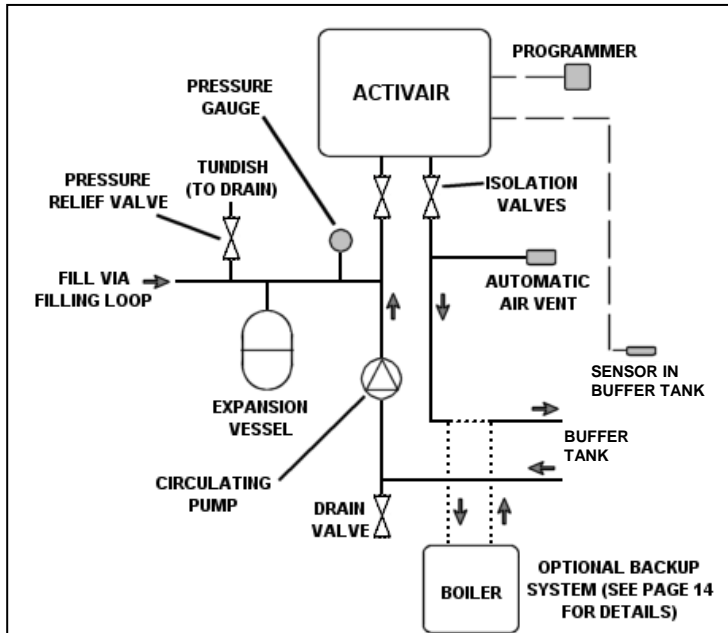

FIG 5 – ACTIVAIRE SIDE (SEALED SYSTEM)

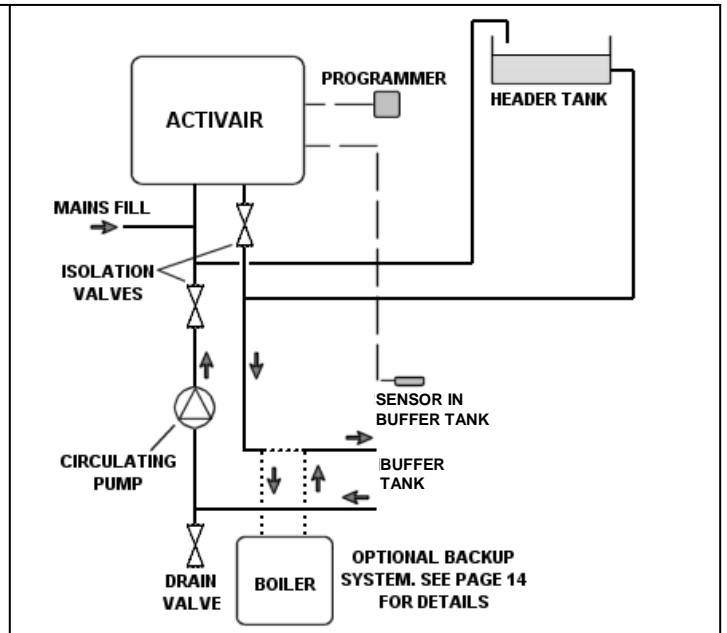

FIG 6 – ACTIVAIRE SIDE (OPEN VENT SYSTEM)

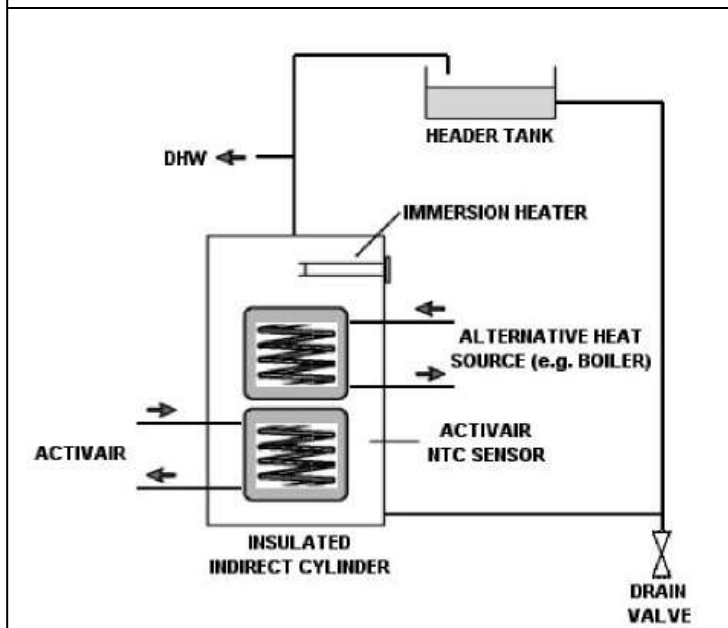

FIG 7 – DHW CYLINDER (OPEN VENT SYSTEM)

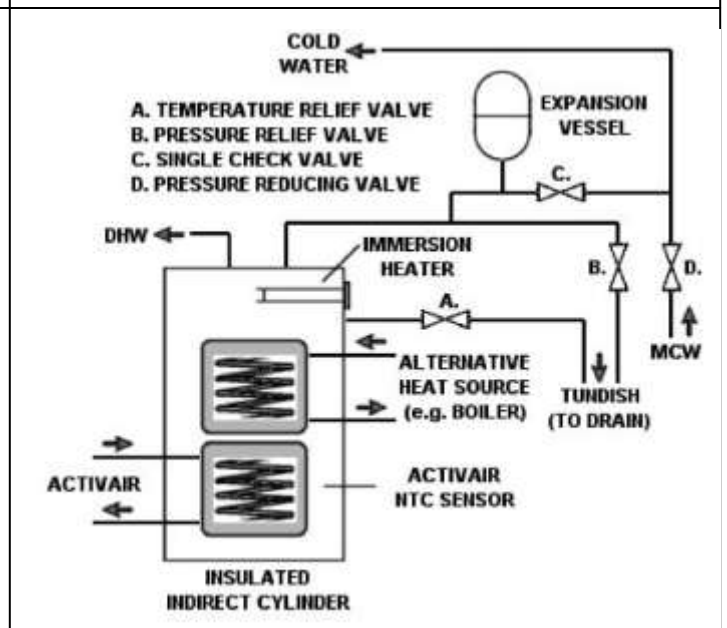

FIG 8 – DHW CYLINDER (SEALED SYSTEM)

SYSTEM SCHEMATICS (cont.)

FIG 9

BUFFER TANK FOR STANDARD OR UNDERFLOOR HEATING CIRCUITS

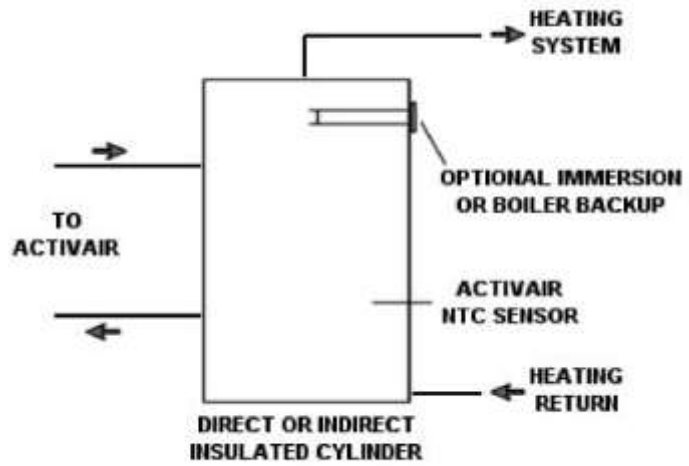
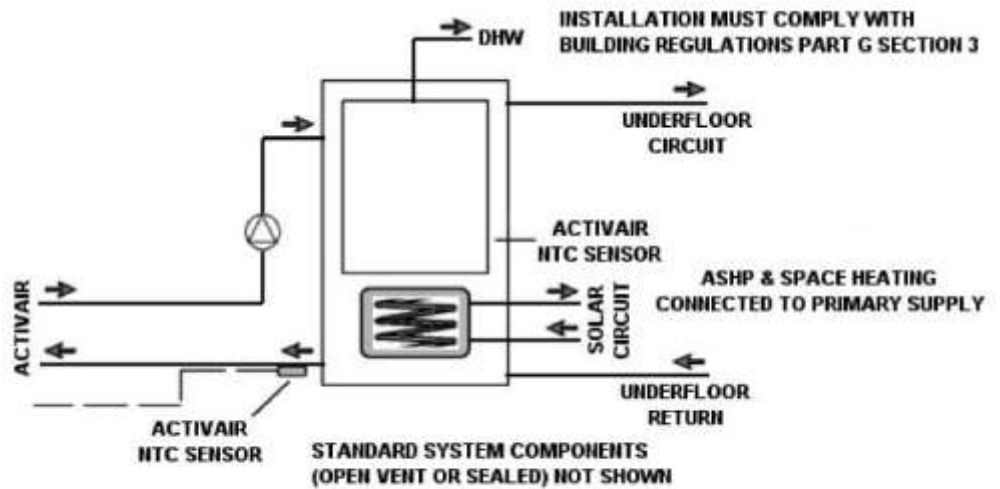

FIG 10 – DHW & HTG VIA TANK-IN-TANK WITH SOLAR COIL



CYLINDER SENSOR

A submersible cylinder sensor is supplied packed with the appliance. The sensor **MUST** be fitted into the cylinder or buffer tank approximately 1/3 up from the base of the tank or cylinder, into a wet pocket if available. If using a dry pocket please ensure heat sink paste is used to give good heat transfer. A compatible NTC-type sensor may be used in place of the one supplied with the Activair. Under no circumstances should the system be run without a sensor fitted in the correct position.

DRAINAGE / DEFROST

In the event that the appliance enters defrost mode (indicated by the appearance of the DEFROST symbol on the programmer display – see **fig. 1**), heat generated by the unit will divert from the heating circuit back to the coil until any ice has melted. In such circumstances, the water formed as a by-product will collect in the bottom of the unit. It is also possible that water will be sucked or blown into the appliance during heavy rain.

The water will drain from holes in the base of the Activair. If the unit is installed outside, provision should be made to drain this water to a soakaway; if the unit is installed indoors, a collection tray should be used, which can either be emptied periodically or piped to a drain or soakaway.

SEALED SYSTEMS

Expansion Vessel

Failure to ensure the correct sized expansion vessel can result in the premature failure of the expansion vessel and associated system components.

Safety Valves

All pressure relief valves fitted to the heat pump side of the system should be rated at 3 bar.

BUFFER TANK SIZING

In accordance with BS EN 15450, the minimum size of the buffer tank should be 12 times the expected kW output of the Activair. The maximum size of the buffer tank is 35 times the expected kW output of the Activair.

LEGIONELLA

When the unit is connected to a domestic hot water cylinder, it is necessary to take steps to combat potential legionella infection. This can be achieved by connecting a secondary heat source to the cylinder, which should be programmed to activate once per week in order to briefly take the water temperature to 65°C or above.

INSTALLATION (continued)

SYSTEM FILLING

Sealed Systems

Before filling the system, ensure that all fittings and joints have been made. Thoroughly flush out the system to remove any swarf and residue from the pipework and associated components.

Fill the system to the pressure required (recommended 1 bar), via an approved filling loop. Ensure all air has been vented from the system before operating the appliance.

Open Vent Systems

Fill via mains pressure to flush air out of the system (see **fig. 11** below for further details). There must be no permanent connection between the appliance and the mains water supply.

Air Removal

If the air is not fully removed from the system, a lockout will occur within the unit (operating parameter **8**), causing it to cease operation. To remove excess air, open the isolation valves to the heating/hot water system and fill using one of the above methods until the air has been removed via the automatic air vent. Should air remain within the Activaire, close the isolation valves to the system and use mains pressure to expell air as shown in **fig. 11** below.

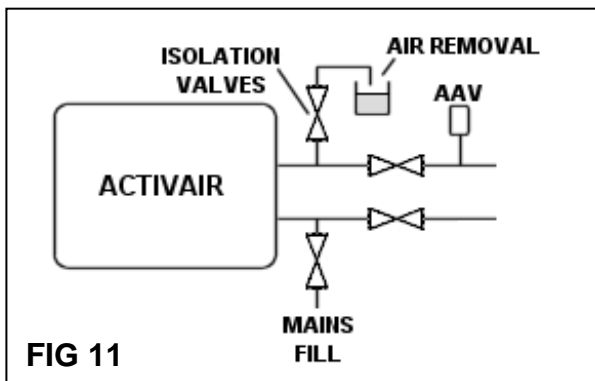

COMMISSIONING

After the safe installation of the heat pump in full accordance with these instructions, it is important that the unit is commissioned to ensure reliable operation:

- 1) Fill the system, in accordance with the filling guide above.
- 2) Switch power on to the unit and set the water temperature on the programmer to 40°C (see operating instructions, **page 7**).
- 3) The SUN symbol will appear at the top-right of the programmer display (**fig 1**) as the unit operates. Run the heat pump until the water temperature has reached 40°C. The SUN symbol will flash when the water reaches this temperature and the unit will cease operation.

- 4) Press and release the search button and check readings 1 to 4. The temperature difference between 1 and 4 should be no more than 25 deg C. If the difference is higher check for impaired water flow.
- 5) Explain all system controls and the maintenance procedure (below) to the end-user. Make adjustments to the programmer settings as requested.

SERVICING & MAINTENANCE

While it is not necessary to carry out an annual service on the appliance, regular inspections may be required, depending upon where the unit is sited.

Note: Isolate the electrical supply to the appliance before accessing the interior of the unit.

INTERNAL INSTALLATION

A visual inspection of the fan and coil should be made once per year. Clean as often as is necessary (e.g. when dirt build-up is visible) and remove any obstructions.

Ensure the supporting base remains stable and capable of supporting the full weight of the appliance, including its water content.

EXTERNAL INSTALLATION

Every Three Months

Visually inspect the appliance, and remove any leaves, plant life or debris from around or inside the unit.

Every Twelve Months

A visual inspection should be made of the fan and coil. Clean as often as is necessary (e.g. when dirt build-up is visible) and remove any obstructions.

Ensure the supporting base remains stable and capable of supporting the full weight of the appliance, including its water content.

If the appliance is installed in a coastal area, the periodic removal of salt may be required from the coil.

Panels

Periodically clean the panels by wiping with a damp cloth. Do not use alcohol, benzene, thinners, glass cleaner, household polish or powders. It may be appropriate to apply a protective wax to the casings, especially in coastal areas.

OPERATING PARAMETER CODES

In certain circumstances, the unit will display a code on the programmer screen (**fig. 1**). A description of these codes and their causes can be found in the chart below:

Code	Description	Cause	Solution
01	Water cylinder temperature cut-out activated	Sensor disconnected Short circuit Faulty sensor	Reconnect sensor to PCB (see internal wiring diagram, fig. 4) Check connection between sensor and appliance. Check sensor for correct operation. Repair or replace as necessary
02	Compressor sensor cut-out activated	Sensor disconnected Short circuit Faulty sensor	Reconnect sensor to PCB (see internal wiring diagram, fig. 4) Check connection between sensor and appliance Check sensor for correct operation. Repair or replace as necessary
03	Compressor outlet temperature cycle	Compressor outlet temperature too high	When compressor outlet temperature has returned to normal, unit will automatically reset
05	Ambient temperature cycle	Ambient temperature too high	When ambient temperature has returned to normal levels, unit will automatically reset
06	Coil temperature cycle	Coil temperature too high	When coil temperature has returned to normal levels, unit will automatically reset
07	Programmer cut-out activated	Short circuit Faulty programmer	Check wiring and settings. Repair or replace as necessary Repair or replace as necessary
08	Refrigerant pressure cut-out #1	No water in appliance Air Lock Impaired Water Flow Cylinder sensor detecting incorrect temperature	Refill system with water (refer to filling guide, page 20). Unit will automatically reset Flush air and refill system with water (refer to filling guide, page 20). Unit will automatically reset Ensure circulating pump is operating correctly, that all pipework is clear and free of obstruction, and is correctly sized for the installation Ensure cylinder sensor is positioned correctly. Ensure cylinder flow and return are correctly piped (refer to system schematics, pages 17-18)
09	Refrigerant pressure cut-out #2	Leak on refrigerant system Operating parameter 8 activated	Repair leak, replace refrigerant (note: only to be carried out by a fully-qualified engineer) See remedies for operating parameter 8

FAULT-FINDING

If the appliance fails to start for no apparent reason and an operating parameter code (**page 21**) is not displayed on the programmer, carry out the following checks:

1. Check for failure in the electrical supply.
2. Check for a blown fuse.
3. Check the circuit breaker (if fitted). If this has tripped reset and restart the appliance.
4. Ensure there is a current 'heat demand' from the programmer. Ensure the programmer clock and timer controls have been set in accordance with the instructions on **pages 6/7** or that it is switched on (if in non-timed mode).
5. Check the programmer settings by pressing the **SEARCH** button for five seconds.

Setting 1 - set at 26.

Setting 2 - set at 18.

Setting 3 - set at 14.

These are factory-set and should not in normal circumstances have been altered. If for some reason the settings do not match the figures above, alteration is made via the **TEMPERATURE ADJUSTMENT** buttons (+/-).

Note: if the appliance has been shut down due to a failure of the power supply, the programmer contains a battery backup, which will allow the preservation of all settings and timings.

If the appliance is operating, but the water temperature is lower than expected:

1. Check that all isolation valves are fully open.
2. Check the water temperature setting is not too low. This can be increased by following the instructions on **page 7**.
3. Check that the vents on the back of the unit and the coil have not become blocked, impeding the air flow.
4. Check the unit has not entered defrost mode (the DEFROST symbol will appear above the temperature display see **fig. 1**). Should this occur, the heat output from the appliance will be diverted to the coil, until any ice build-up has been removed.
5. Ensure there is no air trapped in either the Activair or the heating/hot water system.

If sounds are heard from the appliance, which sound like the passage of water, this is merely the normal movement of the refrigerant within the unit.

If there is power to the appliance and the programmer is providing a 'heat demand' to the unit, yet the unit has not entered running mode (the SUN symbol has not appeared above the temperature display), it may be that one of the safety cut-outs (see **page 8**) has operated. These will typically take several minutes to clear before the unit restarts.

SPARES

Item	Description	Part Number	Qty
1	PCB	224524	1
2	Programmer	224501	1
3	Compressor	224526	1
4	Compressor Capacitor	224530	1
5	Fan Motor	224528	1
6	Fan Motor Capacitor	224539	1
7	Transformer	224506	1
8	Relay	224542	1
9	Relay Cable	224543	1
10	NTC Sensor	224508	1
11	Fan Blades	224545	1
12	Auxiliary Starter	224520	1
13	Programmer Extension Cable	224535	1
14	NTC Sensor PCB Adaptor Cable	224531	1
15	Ambient Temperature Sensor	224546	1
16	Heat Exchanger Temperature Sensor	224547	1
17	Exhaust Temperature Sensor	224548	1
18	NTC Sensor Extension Cable	224536	1



TRIANCO

**TR ENGINEERING LTD
Thornccliffe, Chapeltown
Sheffield S35 2PH
Tel: (0114) 257 2300
Fax: (0114) 257 1419
www.trianco.co.uk**

Copyright in this brochure and the drawings and illustrations contained within are vested in TR Engineering Ltd and neither the brochure or any part thereof may be reproduced without prior written consent.

TR Engineering's policy is one of continuous research and development. This may necessitate alterations to this specification. Instructions correct at time of going to print.