

TRIANCO



**OIL FIRED CENTRAL HEATING BOILERS
FOR BALANCED OR CONVENTIONAL FLUE**



TRIANCO

CE BED 92/42 EEC
EMC 89/336 EEC

USER, INSTALLATION COMMISSIONING & SERVICING INSTRUCTION

Utility 130/150

Utility 160/180

Utility 190/240

To be retained by householder

HEALTH AND SAFETY

INFORMATION FOR THE INSTALLER AND SERVICE ENGINEERS

Under the Consumer Protection Act 1987 and the Health and Safety at Work Act 1974, it is a requirement to provide information on substances hazardous to health (COSHH Regulations 1988).

The Company takes every reasonable care to ensure that these products are designed and constructed to meet these general safety requirements, when properly used and installed.

To fulfil this requirement products are comprehensively tested and examined before despatch.

This appliance may contain some of the items below.

When working on the appliance it is the Users/Engineers responsibility to ensure that any necessary personal protective clothing or equipment is worn appropriate to parts that could be considered as being hazardous to health and safety.

INSULATION AND SEALS

Glass Rope, Mineral Wool, Insulation Pads, Ceramic Fibre, Glass Insulation.

May be harmful if inhaled. May be irritating to the skin, eyes, nose or throat. When handling avoid inhalation and contact with eyes. Use (disposable) gloves, face masks and eye protection.

After handling wash hands and other exposed parts. When disposing, reduce dust with water spray, ensure parts are securely wrapped.

GLUES, SEALANTS & PAINT

Glues, Sealants and Paints are used in the product and present no known hazards when used in the manner for which they are intended.

KEROSENE & GAS OIL FUELS (MINERAL OILS)

1. The effect of mineral oils on the skin vary according to the duration of exposure.
2. The lighter fractions also remove the protective grease normally present on the surface of the skin rendering the skin dry, liable to crack and more prone to damage caused by cuts and abrasions.
3. Skin rashes (oil acne). Seek immediate medical attention for any rash, wart or sore developing on any part of the body, particularly the scrotum.
4. Avoid as far as possible any skin contact with mineral oil or with clothing contaminated with mineral oil.
5. Never breathe any mineral oil vapours. Do not fire the Burner in the open i.e. out of the Boiler as a misfire will cause unburnt oil vapours.
6. Barrier cream containing lanolin such as Rosalex Antisol, is highly recommended together with a strict routine of personal cleaning.
7. Under no circumstances should mineral oils be taken internally.

CONTENTS

| PAGE | | |
|------|---|--------|
| 1. | USER INSTRUCTIONS | 1/2 |
| | After sales service information | 3 |
| 2. | INTRODUCTION | 4 |
| 3. | TECHNICAL INFORMATION | 4 |
| | Outline dimensions | 4 |
| | Technical specifications | 5 |
| | Wiring diagram | 6 |
| 4. | INSTALLATION | 7 |
| | Regulations | 7 |
| | Health and Safety | 7 |
| | Siting the Boiler | 7 |
| | Combustion air (Conventional flue boilers) | 7 |
| | Ventilation (room sealed balanced flue boilers) | 8 |
| | Extractor fan | 8 |
| | Heating and domestic hot water system | 8 |
| | Electrical supply | 8 |
| | Thermostats | 8 |
| 5. | OIL SUPPLY | 9 |
| | Oil storage tank - Steel and Plastic | 9 |
| | Oil supply line | 9 |
| | Single pipe oil supply | 9 |
| | Two pipe oil supply | 9 |
| | Oil De-aerator - Single pipe supply | 9 |
| 6. | FLUE SYSTEM | 12 |
| | Conventional chimney | 12 |
| | BF Low level discharge | 13 |
| | Flue assembly methods & diagrams | 14 -19 |
| 7. | COMMISSIONING | 19 |
| | Procedure | 19 |
| | Handing over | 19 |
| 8. | SERVICING | 19 |
| | Oil Tanks | 19 |
| | Line Filters | 19 |
| | Burner | 19 |

1. Users Instructions

HOW TO USE YOUR TRIANCO BOILER

The Trianco EuroStar has been designed and constructed to give years of trouble free service and these instructions are provided to assist you in obtaining the best performance with the least trouble and cost.

The boiler is fully automatic in operation and requires little attention other than the setting of the thermostat and any system controls such as a room thermostat and time-switch.

TO FIRE THE BOILER

Before firing the boiler, ensure the system is full of water, there is sufficient oil in the storage tank and all valves are open.

1. Check that the Time-switch/Programmer (if fitted) is ON and the room thermostat is calling for heat.
2. Set the boiler thermostat to the desired temperature.
3. Switch on the electrical supply to the boiler and the burner should fire after a few seconds of fan pre-purge.
4. Set the Time-switch/Programmer (if fitted) to the times and programme required.
5. The boiler will now operate automatically, cutting in and out according to the heat demand.

TO STOP THE BURNER

The burner may be stopped by turning the Boiler Control Thermostat fully anti-clockwise to the OFF position 'O'

If the boiler is to be off for a long time, it is recommended that the mains supply to the boiler is switched off or the Time-switch/Programmer (if fitted) is switched to the OFF position.

BOILER CONTROL THERMOSTAT

The boiler control thermostat enables you to select the temperature of the water leaving the boiler. It is calibrated between High and Low in five intermediate settings, corresponding to a temperature range of 82° C (high) to 55° C (low).

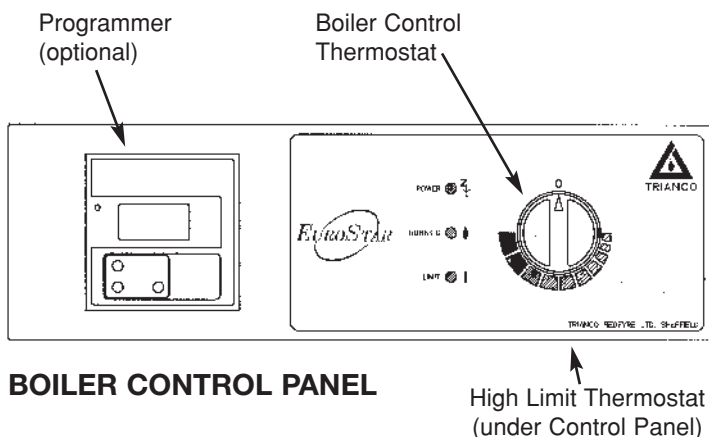

Set the temperature by turning the knob to the required temperature. However, the installer should take into consideration that the return water temperature **must not** drop below 60°C when the appliance is up to full operating temperature.

The thermostat is switched off when the knob is turned fully anti-clockwise with the pointer opposite 'O'

BURNER LOCK-OUT

If the burner fails to light, it will go to lock-out. If this occurs, wait about one minute then remove the front panel and press illuminated reset button to start burner. In the event of the burner not firing wait a further minute and then press the reset button again. If the burner still fails to start, switch off the electrical supply to the boiler.

WARNING - DO NOT ATTEMPT TO START BURNER MORE THAN TWICE

(See Simple Fault Finding before contacting your Service Engineer).

SYSTEMS CONTROLS

ROOM THERMOSTAT

The room thermostat should not be positioned near a source of heat such as a radiator or exposed to the sun as this will cause the central heating to switch off before the room is up to temperature. Follow the manufacturer's instructions for best siting position for the thermostat.

TIME-SWITCH/PROGRAMMER

When choosing the operating times for your boiler, it is useful to remember that central heating usually takes between half an hour to an hour before it becomes effective.

It is suggested that the Time-Switch/Programmer is set to bring on the heating about an hour before heating is required.

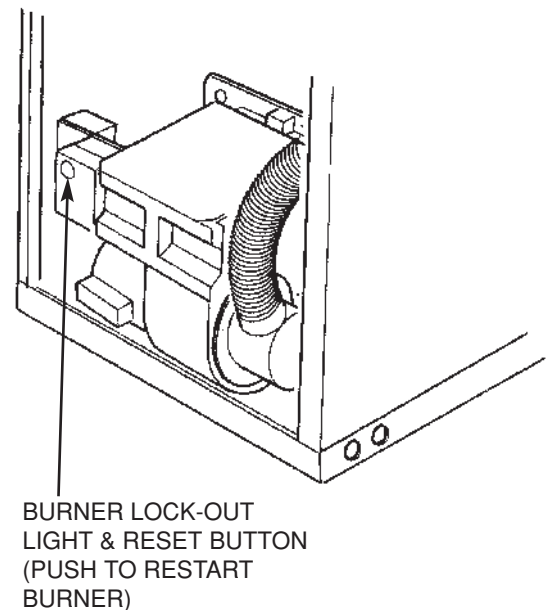

It is also worth noting that the heating system will usually remain effective for up to half an hour after boiler shut down. The timer can therefore be switched off earlier as an economy measure.

FROST PROTECTION

If the boiler and central heating is shut down for many hours during very cold weather, the water may be in danger of freezing and, as such, it is advisable to protect the installation with a frost thermostat.

Where the system is not protected, the boiler should be left switched on and the room thermostat set to a low setting e.g. 7° C (45° F) to prevent the building temperature falling too low.

If the system is shut down for a long period during very cold weather, it is advisable to completely drain the system. However, frequent draining should be avoided, especially in hard water areas, as this could lead scaling of the boiler waterways.

SHUTTING DOWN FOR THE SUMMER

If the boiler is shut down for the summer months, it is advisable to have it serviced and thoroughly cleaned as soon as possible to minimise corrosion of the heating surfaces.

OIL

The recommended oil for your boiler is 28 sec.Kerosene (BS 2869:1983 Class C2).

OIL TANK

Always ensure the tank is topped up at regular intervals, do not wait until the tank is nearly empty before refilling, otherwise sludge and water could be sucked into the oil pipe to affect the burner's operation and reduce pump life.

After a delivery of oil, it is recommended that the oil is allowed to settle in the tank for about half an hour before restarting the burner.

Boiler Model

Serial Number

Fuel Type

Oil Tank Capacity

Oil Supplier 1 

Oil Supplier 2 

Sludge and water caused by condensation should be drawn off at the tank drain-cock annually.

SIMPLE FAULT FINDING

If the burner fails to start for no apparent reason, make the following checks before calling your Service Engineer.

1. Check for failure in the electrical supply e.g. a power cut
2. Check for a blown fuse. If the fuse has blown and on replacement blows again, switch off the mains electrical supply to the boiler and call your Service Engineer.
3. Check that there is adequate oil in the tank and the shut-off valves are open.
4. Check for burner lock-out. Press the reset button and burner should fire. DO NOT PRESS MORE THAN TWICE. Refer to 'Burner lock-out' for further advice.

Note: If the boiler has been off as a result of a power failure, it will be necessary to reset the Time Switch/Programmer to the correct time unless it has a built-in power reserve.

SERVICING

To ensure efficient and reliable operation of the boiler, it is essential that the oil burner is initially commissioned by an OFTEC trained and registered engineer and an annual service is given thereafter.

Notes:

ELECTRICAL SAFETY CHECKS SHOULD BE CARRIED OUT BY A QUALIFIED ELECTRICAL ENGINEER

- a It is the responsibility of the installer to ensure proper commissioning is carried out.
- b It is a requirement of the boiler's guarantee and any extended warranty that an annual service is carried out by a qualified engineer, along with the original commissioning. (FORM CD 108CD11).

Commissioning Engineer

Signature

Company Name

.....

Address

.....

.....

.....

Tel. No:

TRIANCO

CUSTOMER AFTER SALES SERVICE INFORMATION

A step by step guide to reporting a fault with your appliance

A qualified field SERVICE ENGINEER is available to attend a breakdown or manufacturing fault occurring whilst the appliance is under guarantee.

The appliance must be made available for service during normal working hours, Monday to Friday (no weekend work is accepted).

A charge will be made where:

- Our Field Service Engineer finds no fault with the appliance
or
- The cause of a breakdown is due to other parts of the plumbing/heating system (including oil line/lack of oil), or with equipment not supplied by Trianco.
or
- Where the appliance falls outside the guarantee period (see terms and conditions enclosed).
or
- The appliance has not been correctly installed, commissioned or serviced as recommended (see commissioning, installation and servicing instructions)
or
- The breakdown occurs immediately following an annual service visit. In this instance your appointed Service Agent must check all his work PRIOR to requesting Trianco to attend.

NOTE: Burner nozzles are currently guaranteed until the first service.

Over 50% of all service calls made are found to have no appliance fault.

What to do in the event of an appliance fault or breakdown:

Step 1: Always contact your installer or commissioning engineer in the first instance, who must thoroughly check all his work PRIOR to requesting a service visit from Trianco.

Step 2: If your appliance has developed an in-guarantee fault your installer should contact Trianco Service Centre for assistance.

What happens if my installer/engineer is unavailable?

Step 3: Contact Trianco Direct. We will provide you with the name and telephone number of our Service Agent. However, a charge may apply if the fault is not covered by the appliance guarantee (payment will be requested on site by our independent Service Agent).

PLEASE NOTE:

Unauthorised invoices for attendance and repair work carried out on this appliance by any third party will not be accepted by Trianco.

SERVICE CENTRE AND TECHNICAL SUPPORT

Tel: 0114 257 2300 Fax: 0114 257 2338

Hours of business Monday to Thursday 8.30am - 4.45pm

Friday 8.30am - 2.30pm

2. INTRODUCTION

The Trianco EuroStar meets the CE European requirements of LVD EN 60335/1 and EMC 89/336 EEC.

The 130/180 boilers is suitable for connection to a conventional chimney and conversion to BF low level.

The matched pressure jet burner which is relatively quiet in operation and the head design ensures clean and efficient combustion with low NO_x emissions

The EuroStar boilers are suitable for all normal open vented central heating and indirect hot water systems. They can also be used with sealed systems up to a working pressure of 3 bar with the appropriate sealed system safety equipment.

Two flow and return sockets each side are provided to facilitate connection to the heating and hot water systems.

Burner servicing is carried out from the front of the boiler and the top mounted flu-cover permits easy access for the removal of the flue-baffles and cleaning of heating surfaces

Trianco EuroStar boilers are supplied with the burner set for Kerosene 28 sec. Class C fuel to BS 2869 to meet the Building Regulation requirements for low level Balanced Flue discharge.

Important Notice:

To comply with regulations in force, your new boiler must be installed and commissioned by an OFTEC-registered engineer. The installation must also comply with current Building Regulations, Part L.

Failure to meet the terms of these requirements may invalidate your guarantee.

THE PERSON(S) WHO INSTALLS THIS APPLIANCE, COMMISSIONS, SERVICES OR CARRIES OUT ANY REMEDIAL WORK, IE ELECTRICAL FAULT FINDING, MUST HAVE SUITABLE ENGINEERING QUALIFICATIONS

3. TECHNICAL INFORMATION

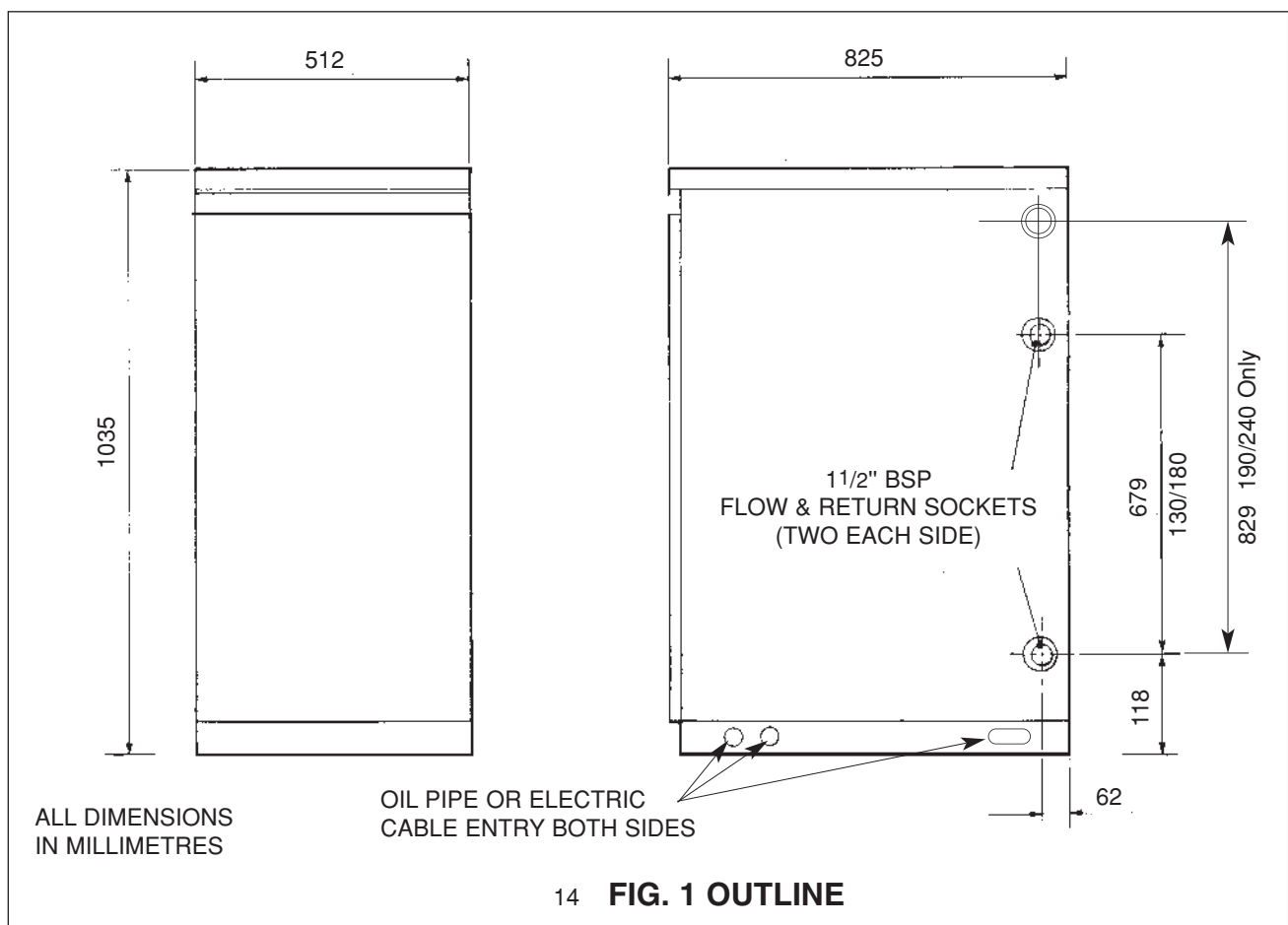

TECHNICAL SPECIFICATION

| EuroStar Boiler | Models | 130/150 | 160/ 180 | 190/240 | |
|-------------------------|--|------------------|-----------------|------------------|--|
| Rated Input | (Btu/h) (kW) | 163,000 47.77 | 195,500 57.3 | 261,000 76.49 | |
| Rated Output | (Btu/h) (kW) | 150,000 44.0 | 180,000 52.7 | 240,000 70.3 | |
| Burner | Max | Max | Max | Max | |
| Weight (empty) | (kg) (lb) | 200 440 | 218 480 | 232 511 | |
| Water content | (litre) (gal) | 42 9.25 | 51 11.2 | 62 13.7 | |
| Flow & return sockets | (in.) | 1 1/2" BSP | | | |
| Flue Socket Dia. (C.F.) | (in.) | 6 | | | |
| Max. operating pressure | (bar) (psi) | 3 43.5 | | | |
| Test Pressure | (bar) (psi) | 4.5 65.3 | | | |
| Starting Current | (amp) | 3.5 | | | |
| Running Current | (amp) | 0.77 | | | |
| Control Thermostat | - Adjustable up to 82° C | | | | |
| Limit Thermostat | - Factory set at 110° C (manual reset) | | | | |
| Casing Finish | - Stove enamelled white, with coloured fascia trim | | | | |
| Thermal Insulation | - Boiler casings insulated with fibre glass | | | | |
| Electrical Supply | - 230v ~ 50 Hz | | | | |

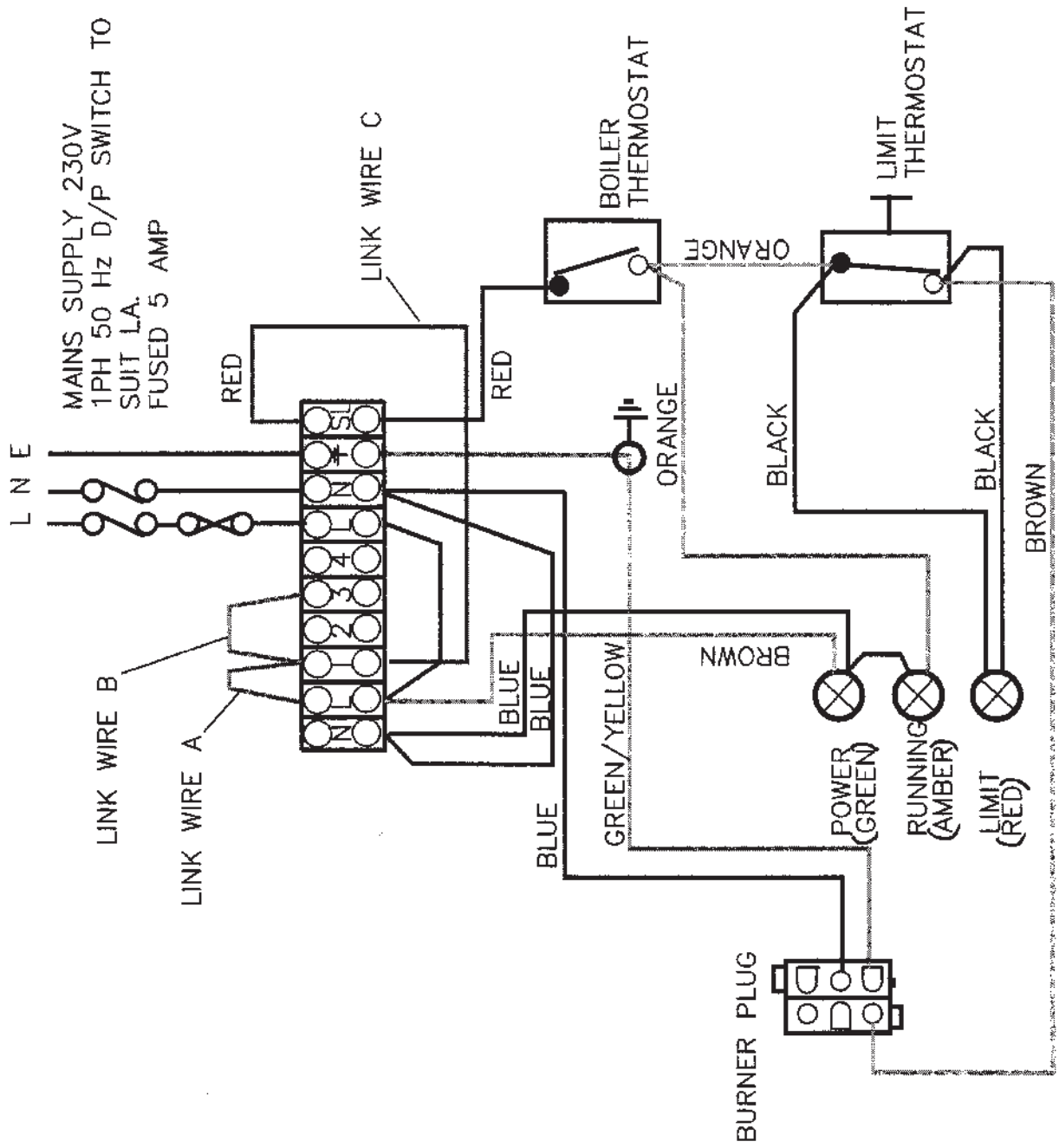

FIG. 2 WIRING DIAGRAM

4. INSTALLATION

Regulations

Installation of the boiler **must** comply with the following British Standards and Regulations:

BS 5410: Part 1 - Code of Practice for Oil Firing.

BS 5449 - Forced Circulation Hot Water Central Heating Systems.

The Building Regulations - Part 'J' (England and Wales)
Part 'F' Section 111 (Scotland)
Part 'L'

The Control of Pollution (Oil) Regulations
Current I.E.E. Regulations
Local Water Undertakings By-laws
OFTEC Installation Requirements for Oil Fired Boilers and Oil Storage Tanks.

Health And Safety At Work Act

The installer should be aware of his responsibilities under the Act and provide, where necessary, appropriate protection for persons carrying out the installation.

In the interest of safety, the boiler should be installed and commissioned by a competent engineer, preferably OFTEC trained and registered.

A useful guide to Safe Working Practices for Oil Firing Technicians is published by OFTEC.

ELECTRICAL WORK SHOULD BE CARRIED OUT BY A QUALIFIED ELECTRICAL ENGINEER

Siting the Boiler

Sound Levels

Whilst the low sound level of the Trianco EuroStar boiler makes it eminently suitable for utility room installation, the following aspects should be considered before installation:

- Some people are particularly sensitive to even low noise levels so this aspect should be discussed with the householder.
- Small rooms tend to amplify noise, particularly if the wall construction is hollow or the surface tiled.
- A chimney passing through a bedroom can some times transmit noise.
- Low level flue terminals produce some exhaust noise, so care should be taken when siting adjacent to neighbouring property, patios and play areas.

Clearance and Service Access

When siting the boiler, ensure adequate clearance is allowed for making water and flue connections and a headroom of 450mm (18") is provided for removal of flue baffles and flu-way cleaning. A clearance of 750mm (30") is also required at the front of the boiler for burner maintenance.

Hearth

The boiler **MUST** be fitted on a non-combustible base. Also the floor must be level and capable of supporting the installed weight of the boiler, including its water content.

Combustion Air (Conventional flue boilers)

The provision of an adequate supply of combustion air is essential for the efficient and safe operation of the boiler. The air opening should be positioned so as to cause the least possible draught to the occupants and located so it is not liable to be accidentally blocked.

British Standard Code of Practice for Oil Firing BS 5410: Part 1 requires a permanent air.

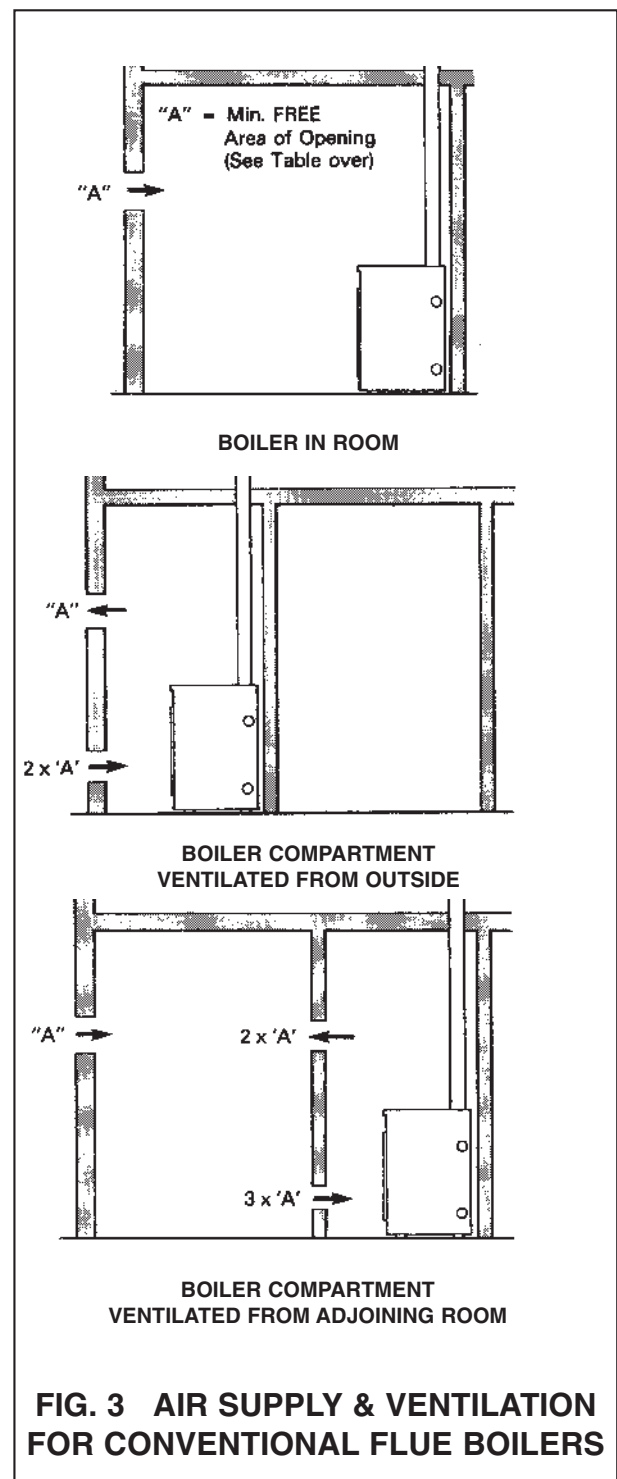

British Standard Code of Practice for Oil Firing BS 5410: Part 1 requires a permanent air inlet opening of 550mm² per kW of boiler rated output.

The following air openings are therefore required for Trianco EuroStar boilers:

| EuroStar Model | Minimum FREE Area opening 'A' |
|----------------|-------------------------------|
| 130/180 | 289 CM ² |
| 190/240 | 385 CM ² |

Extractor Fan (conventional flue only)

If the boiler room has an extractor fan, the combustion performance of the appliance must not be affected when the fan is running and all doors and windows are closed. A flue gas check on the CO₂% and smoke number must be carried out to prove that combustion is satisfactory.

Heating and Domestic Hot Water Systems

The heating system should be installed in accordance with current HVCA Codes of Practice and BS 5449 Part 1 'Forced Circulation Hot Water Systems'.

Water connections can be made to the boiler using both pairs of flow and return tappings or, alternatively, single diagonally opposite tappings can be used.

Fit drain-off cock in the lowest part of the system.

Where a boiler is also used for providing domestic hot water, a double feed indirect cylinder to BS 1566 Part 1 must be used.

MAKE SURE ALL UNUSED BOILER TAPPINGS ARE PLUGGED BEFORE FILLING THE SYSTEM.

Flush out the system to remove any swarf or residues before fitting circulating pump.

Failure to comply with these recommendations may result in there being a temperature build-up within the boiler/system causing noisy operation.

Electrical Supply 230V 1 Phase 50Hz (Fused 5 Amp)

Note: THIS APPLIANCE MUST BE EARTHED

All electrical wiring must be carried out by a qualified electrician in accordance with current I.E.E. Regulations and any Local Regulations that may apply.

The 230v - 50 Hz electrical supply must be fused by a double pole switch with a contact separation of at least 3mm in both poles, and shuttered socket outlet (both complying with the requirements of BS 1363) adjacent to the boiler. Fuse supply at 5A. The minimum requirement for the power supply cable should be a PVC sheathed flexible cord, at least 0.75mm² (24 x 0.2mm) (code designation H05 VV-F or H05 VVH2-F) as specified in table 16 of BS 6500.

This appliance **MUST** be earthed and the electrical supply earth cable must be of a greater length than the current carrying conductor cables (ie live and neutral supply cables).

All external cables entering the control box must be secured in position by strain relief bushes supplied (see diagram on how to secure cable).

Terminal connections are also provided in the control panel for ancillary controls.

See wiring diagram Fig. 2

Warning - High and Low Voltage

In certain parts of the country, where there is a known risk of high or low voltage fluctuations, the oil burner shall be prevented from starting by the use of a voltage sensitive device if the voltage drops or increases sufficiently to endanger the installation.

Thermostats

The boiler is fitted with a variable setting control thermostat and a pre-set limit thermostat. Should the boiler thermostat malfunction, the limit thermostat will take over control and shut down the boiler, illuminating the red light.

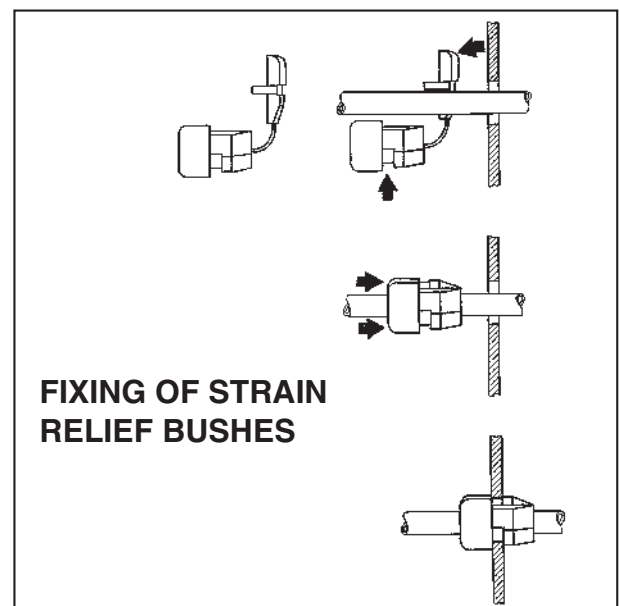

5. OIL SUPPLY

Oil

The oil burner is factory set to burn 28 sec. Kerosene to BS 2869.

Note: Only Kerosene is permitted for low level balanced flue discharge.

Oil Storage Tanks

Size and Location of Tank

The tank should be large enough to allow for economic deliveries and be located in the most unobtrusive position, having regard to the need for safety, filling, maintenance (if steel tank) and the head of oil required.

Whilst it is highly unlikely that a fire could start from an oil tank, it does however need to be protected from a fire that may originate in a nearby building. The tank should therefore not be located nearer than 1.8 metres from a building, nor closer than 760mm from a site boundary. Where a tank has to be less than 1.8 metres, the building wall must not have any openings other than small ventilation openings. The wall shall have a half hour resistance to an internal fire and extend 1.8 metres from any part of the tank.

Alternatively, a non-combustible radiation barrier must be provided which meets the requirements of BS 5410. This standard applies to tanks up to a capacity of 3,400 litres.

Steel Tanks

Steel tanks should comply with the requirements of BS 799, Pt. and mounted on brick or block piers with a waterproof membrane between the piers and tank.

The tank should be fitted with fill and vent connections (weather protected), a drain-off cock, shut-off valve and an oil level indicator.

Plastic Tanks

Polyethylene tanks are now widely used because of their advantages over traditional steel tanks:

- (a) They do not need pier supports and can be mounted directly on any flat surface giving uniform support for the tank base.
- (b) They do not corrode and therefore never need painting.
- (c) They are easier to handle because of their lower weight.
- (d) They have a 10 year manufacturer's guarantee.

Plastic tanks should be fitted with similar components to those used with steel tanks.

Fire Protection

To comply with building regulation **Section J5:**

- 1 Where a storage tank is close to a dwelling, fire cladding must be provided to the eaves, if less than 1.8m from the top of the tank.
- 2 The cladding must extend 300mm beyond the tank.
- 3 The tank must be sited on a non-combustible base.

Pollution Protection

To comply with building regulation **section J6**, the tank must be 'bounded' (i.e. double walled) if:

- 1 The tank is less than 10m from a stream.
- 2 The tank is less than 50m from a well, spring, or drinking water.
- 3 The tank cannot be viewed from the delivery point.
- 4 In the event of a leak, there is a risk of oil reaching a manhole cover or drain.
- 5 The tank capacity exceeds 2500 Litres.

Oil supply line

A long life flexible oil hose, and shut-off valve are supplied with the boiler. A filter is required.

The oil shut-off valve should be fitted as close to the burner as practicable to enable the burner to be disconnected without undue loss of oil. The filter must be connected in the oil supply pipe and positioned either inside or outside the building.

Fire Valve

A fire-valve must be fitted in the oil line outside the building with its sensing phial positioned within the boiler casing below the control panel. A clip is provided for retaining the phial.

All oil line joints must be completely sealed and the total pipe run thoroughly flushed out before connecting to the burner. No soldered joints are permitted in the oil line.

The oil line can be fed into the back of the boiler base tray or through the holes at the side.

Single pipe oil supply (Fig. 4)

When, the bottom of the oil supply tank is above the burner, a single pipe gravity system can be used. The oil supply pipe must be connected to the suction port on the burner pump via the flexible hose.

Two pipe oil supply (Fig. 5)

Where, the bottom of the oil storage tank is below the burner, a two pipe suction lift system is necessary.

When using a two pipe system, it is important that the by-pass plug (supplied with burner) is fitted, in the pump as shown in separate burner details leaflet. An additional flexible hose is also required.

A spring loaded non- return valve must be fitted in the suction line to stop the oil running back to the tank. A filter, shut-off valve and fire valve must also be fitted in the line.

No valves are permitted in the return line which must remain unobstructed at all times.

Notes:

- (1) The pump suction should not exceed 0.4 bar, otherwise dissolved gas will be released from the oil to affect combustion.
- (2) The return pipe must end at the same level as the suction outlet to prevent loss of prime.
- (3) The outlet from the tank should be approximately 75mm (3 in) above the bottom to prevent sediment and water being drawn into the supply pipe.

**Oil De-aerator -
Single pipe supply (Fig. 6)**

Where a two pipe suction lift system is required, but the return pipe is too long, or impractical to run, an Oil De-aerator can be used. The burner is piped as for a two pipe system up to the Oil De-aerator but only a single

pipe is required to be run back to the oil storage tank. A none-return valve is not required with this system but the bypass plug must be fitted in the pump as for a two pipe system.

The Oil De-aerator which should be fitted close to but not inside the boiler casing, is available from most Builders Merchants and some Oil Tank manufacturers.

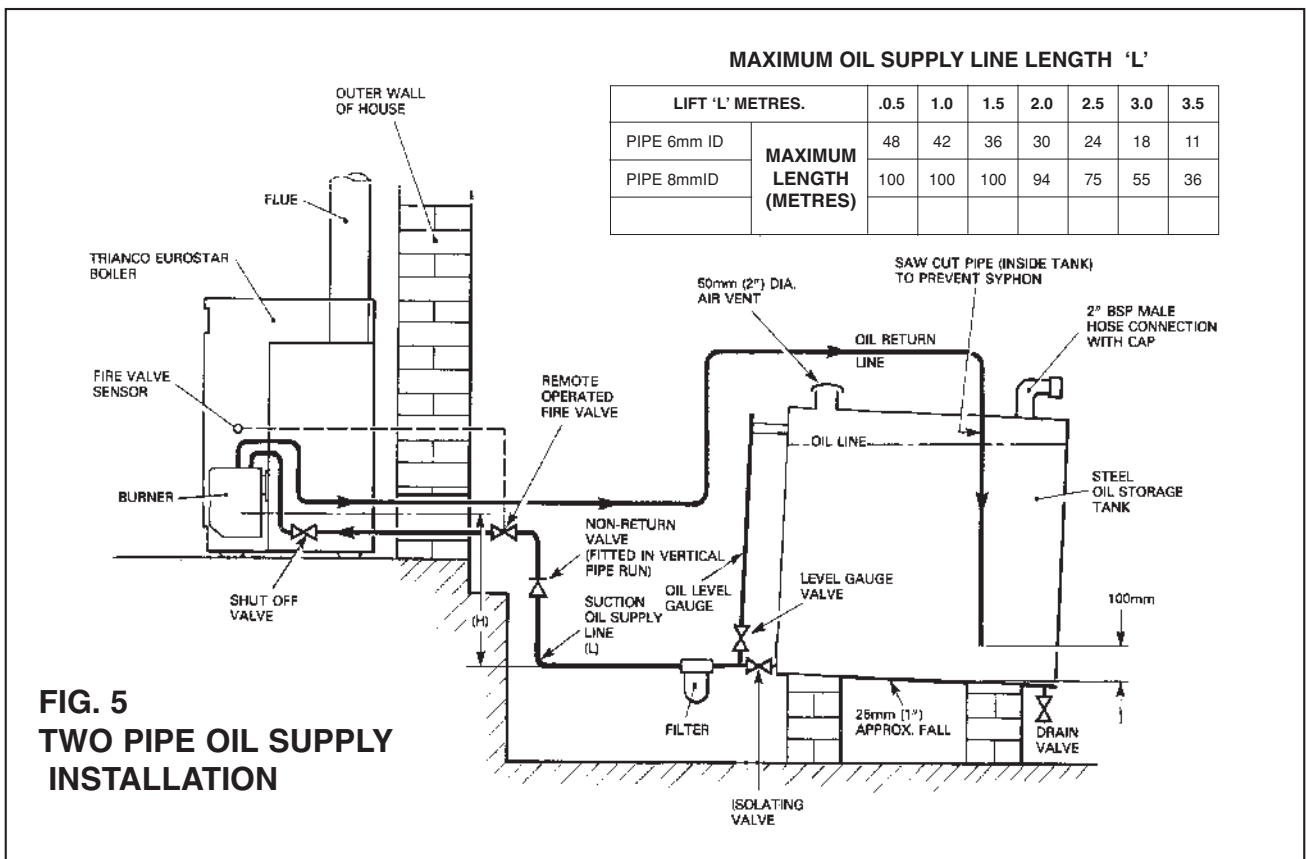
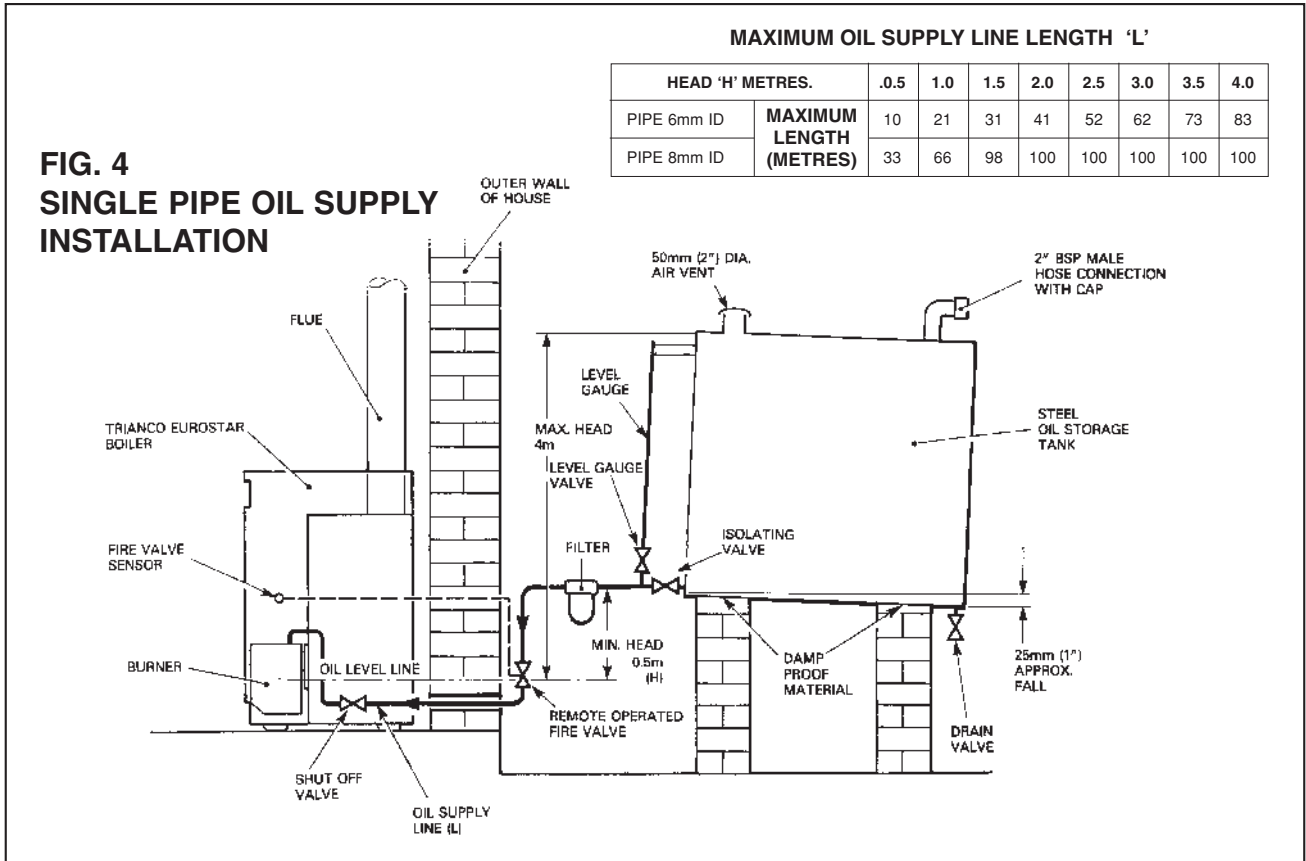

REFER TO MANUFACTURERS
INSTRUCTIONS FOR 'OIL DE-AERATOR'
INSTALLATION DETAILS

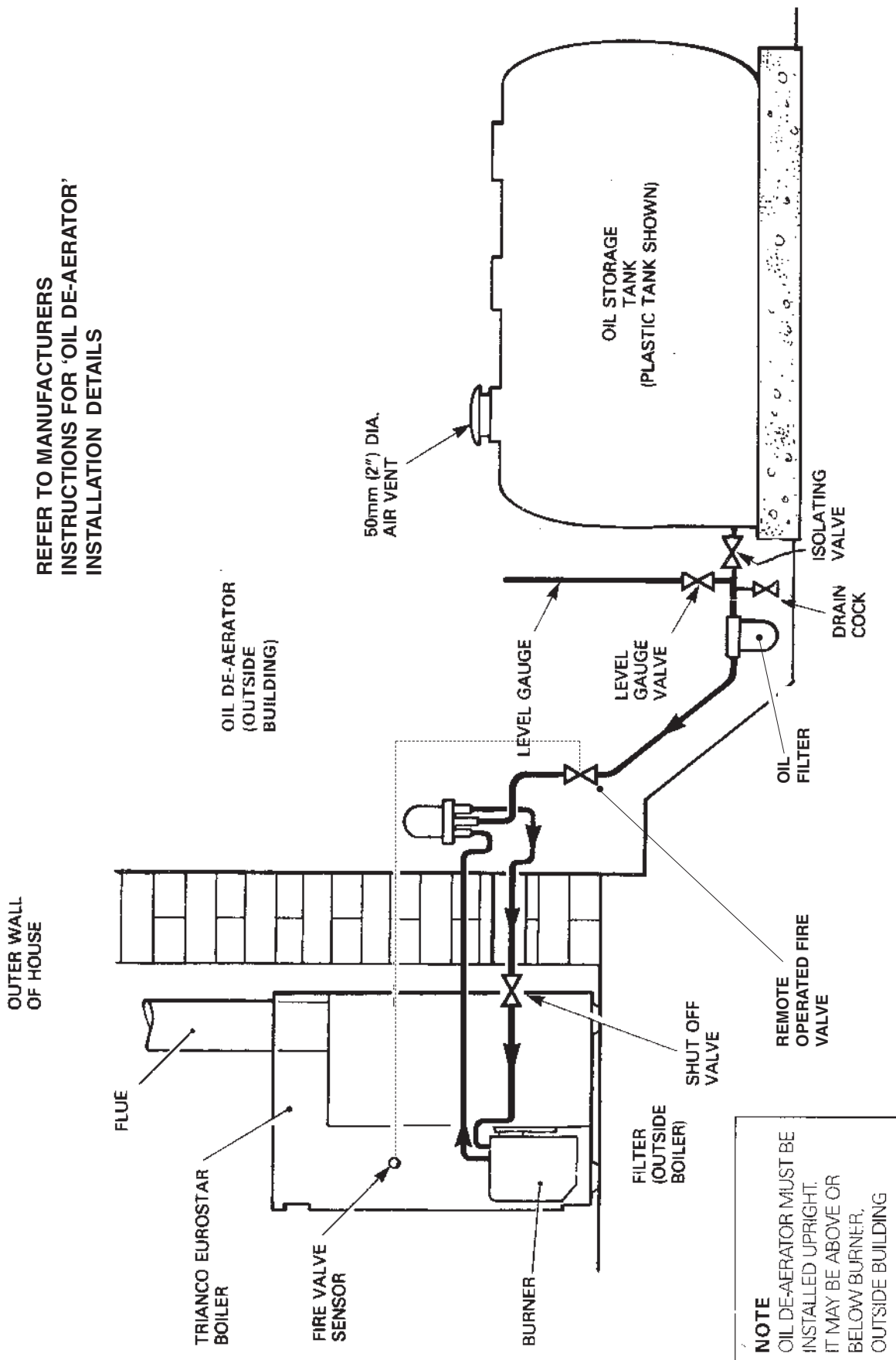

FIG. 6 DE-AERATED OIL SUPPLY INSTALLATION

6. FLUE SYSTEMS

To evacuate the products of combustion safely and thoroughly, the boiler must have an efficient flue system. The design and construction of the Trianco Low Level Discharge Balanced Flue Kits already takes these factors into account so the following guidance notes are for conventional chimneys. Reference should also be made to BS 5410 Part 1 if further information is required on conventional chimneys.

Conventional chimney (Fig. 7)

- (a) The chimney should rise as vertically as possible and terminate at a point not subject to down draughts or wind eddies.
- (b) Brick and masonry chimneys must be lined with a moisture and acid resistant liner of the same diameter as boiler flue outlet.

The use of a flexible stainless steel liner is a convenient method of lining an existing chimney and this should be back filled with 'Vermiculite' or similar insulating material to retain heat.

A flexible liner should also be used in chimneys fitted with large diameter clay liners to reduce the flue bore and improve the thermal insulation.

Notes:

- (1) In view of the EuroStar's high thermal efficiency, it is important that a liner is fitted and back-filled with vermiculite, otherwise condensation problems could result.
- (2) Before fitting a liner, the chimney must be thoroughly cleaned free from all traces of soot and scale.
- (c) A factory made insulated chimney complying with BS 4543 Part 3 may be considered as an alternative to a structural chimney both for new and existing buildings.
- (d) The in-built flue gas resistance of the EuroStar is such that it allows the boiler to operate reliably over the wide range of chimney draughts encountered from typical domestic chimneys.

The use of a draught-stabiliser should not be necessary nor is it desirable since it allows flue noise to be emitted into the room and it could cool the chimney condensing

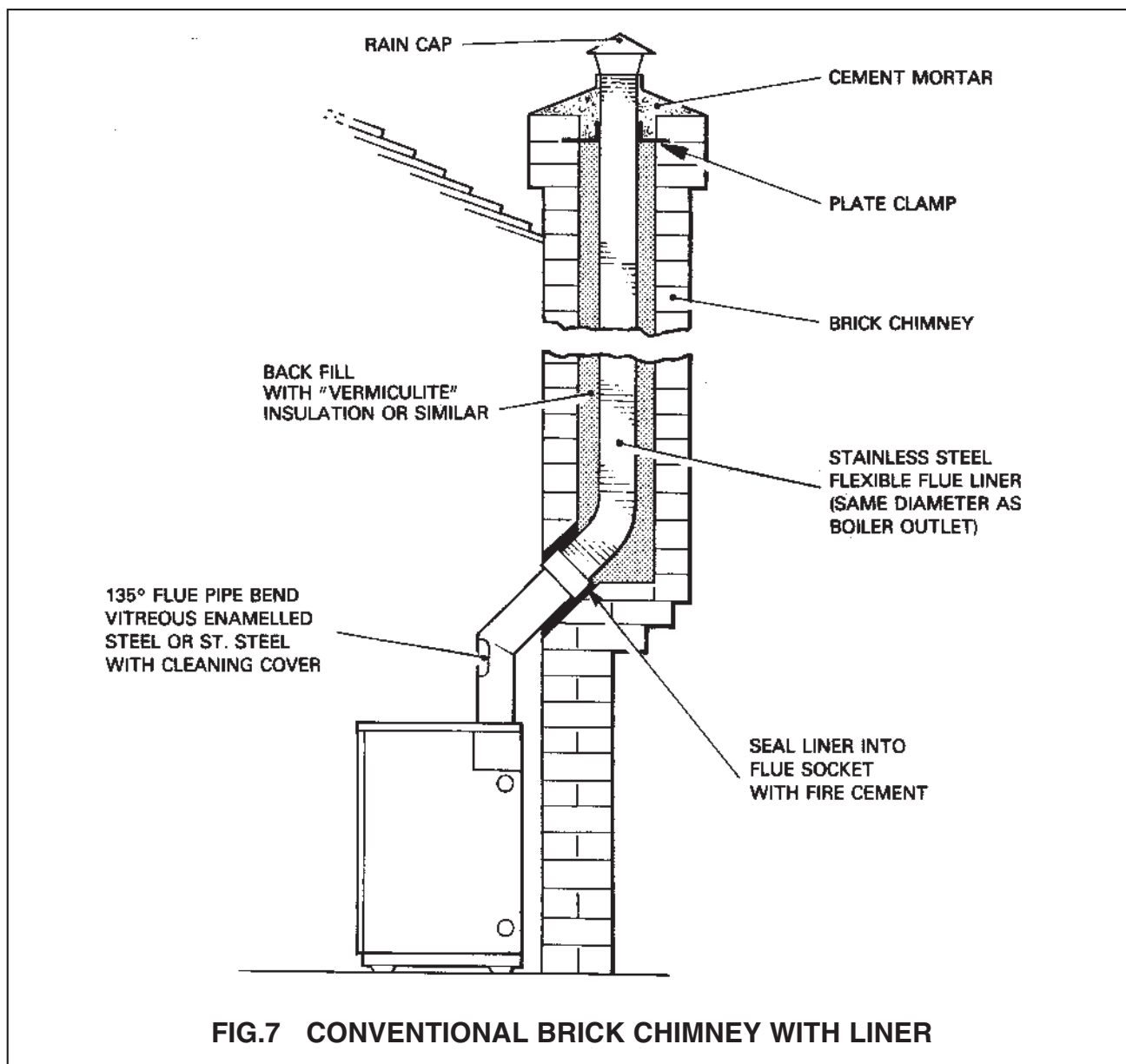

Balanced Flue Systems (optional extra)

The Trianco balanced flue system offers much greater flexibility for siting, the boiler compared with a conventional chimney. The only requirement is for a suitable outside wall to fit the horizontal discharge terminal.

In addition to the siting benefit, the performance of balanced flue boilers is virtually unaffected by high wind conditions since the wind pressures are applied equally to both air intake and flue gas discharge, thus creating a balanced condition.

Whereas some balanced flue boilers rely on case sealing to achieve a room seal, Trianco boilers have a sealed air duct system which maintains the room sealed performance even when the casing door is removed for burner commissioning or adjustments.

The use of the balanced flue principle also enhances the overall thermal efficiency of the boiler since the incoming air extracts waste heat from the flue and returns it as pre-heated air to the burner where it aids combustion.

INSTALLATION NOTES

(a) Location (Fig. 8)

Modern balanced flue boilers are designed to operate at low noise levels. However, when positioning your boiler, it is not recommended to have the terminal facing a neighbours property or patio etc. It should also be positioned to avoid products of combustion entering the building.

(b) Flue Sealing

As the flue system operates under positive pressure, it is essential to seal all flue joints. Apply a thin bead of silicone sealant (supplied) around flue pipe spigot before inserting into socket and all other joints.

(c) Fuel

Only Kerosene 28 sec. Class C2 is permitted for boilers using low level flue discharge.

(d) Important

Trianco Balanced Flue Kits have been designed primarily to use with Trianco boilers and as such compatibility with other makes of boiler cannot be guaranteed.

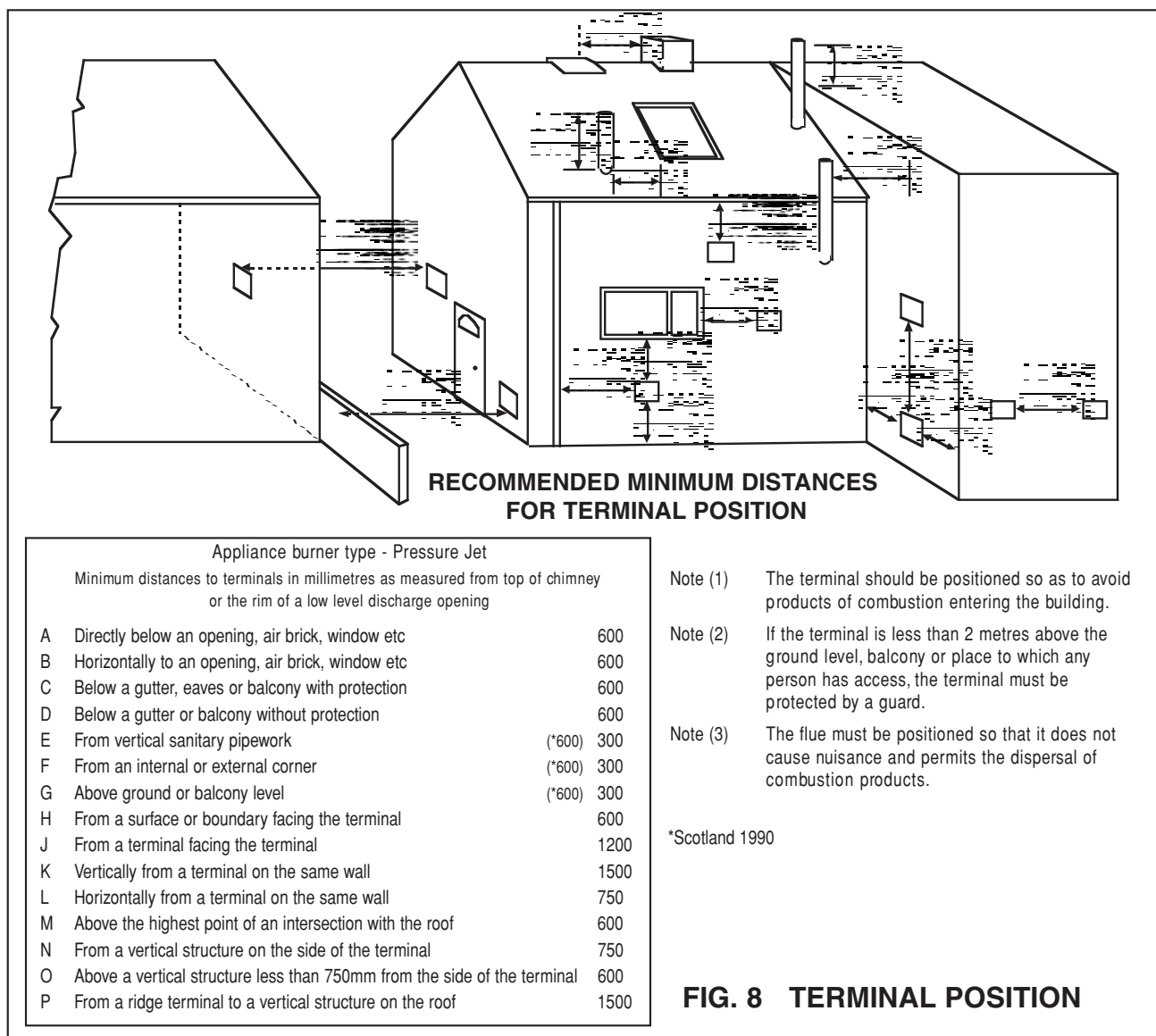

130/180 BOILERS ONLY (KIT 2299)

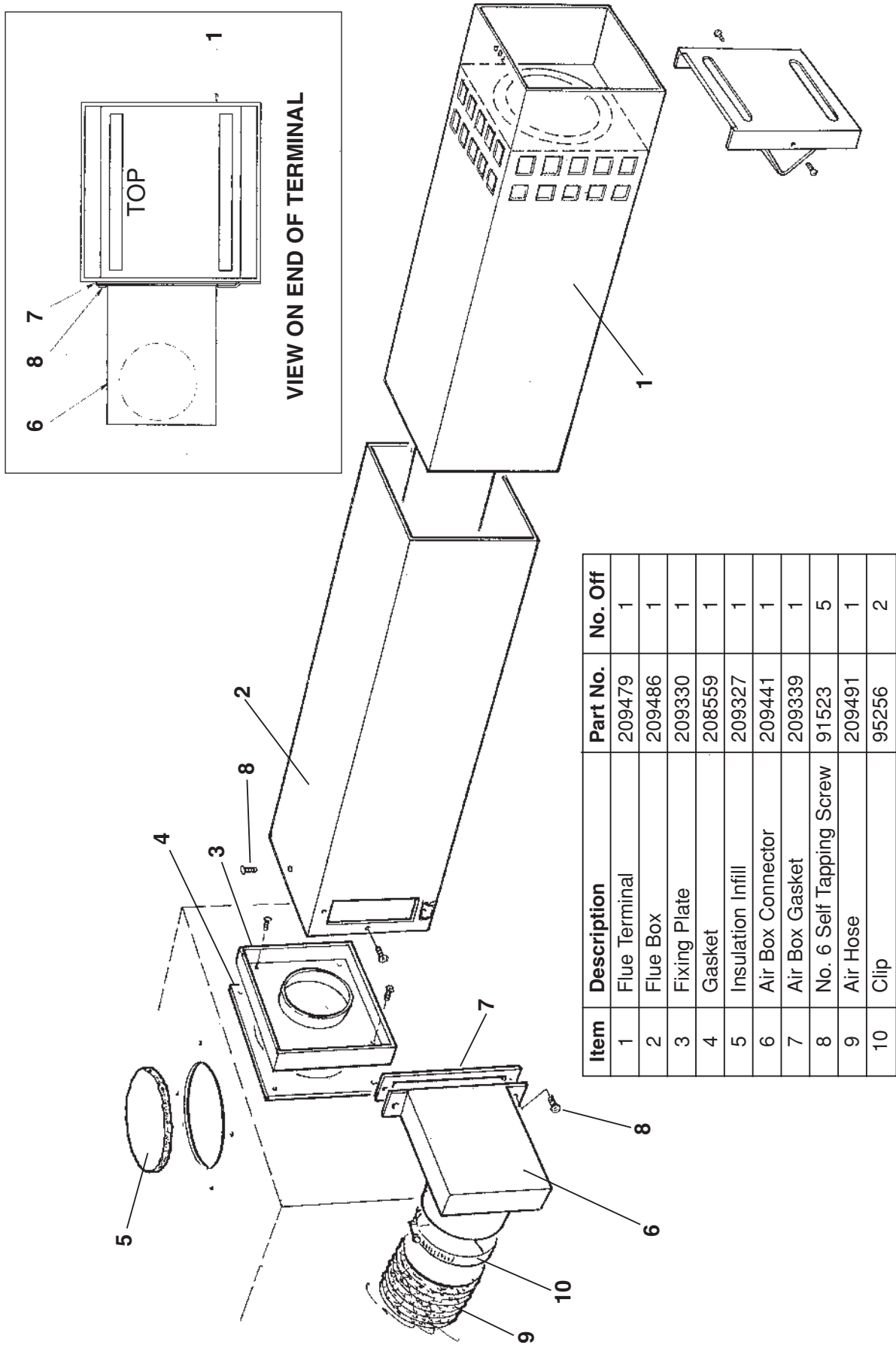
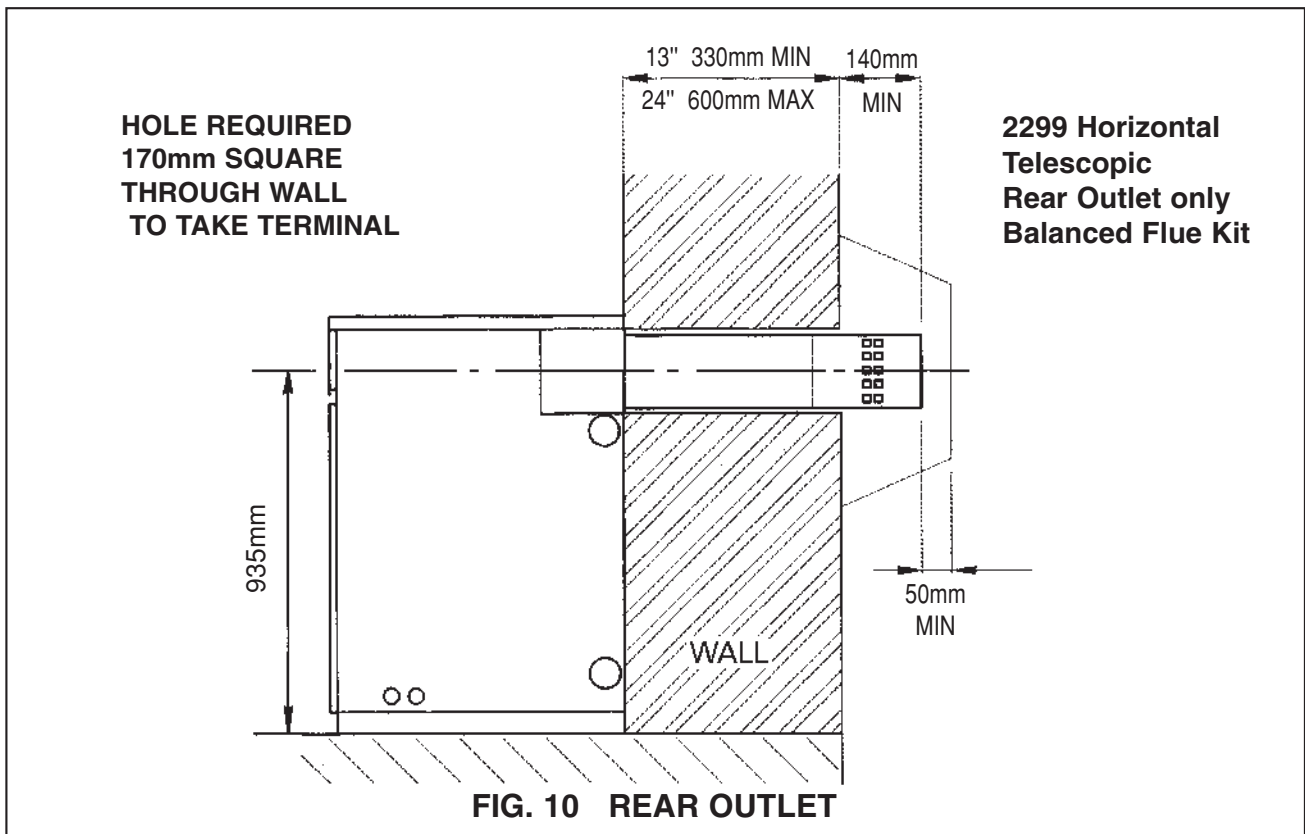

FIG. 9 BALANCED FLUE KIT EXPLODED VIEW

130/180 BOILER ONLY



ASSEMBLY METHODS

- Having decided the position of the boiler, cut a hole in the wall to take the balanced flue kit (refer to diagram for dimensional details)
- Before placing the boiler in position remove the top casing and unscrew the blanking plate off the back of the flue collector box.
- Remove the flue socket box off the top of the flue collector box leaving gasket in position. Place infill insulation piece flue opening.
- Using blanking plate previously removed, blank off flue opening in top of flue collector box, secure with 4-M5 set screws.
- Secure fixing plate to back of flue collector box using 4-M4 set screws and gasket.
- Boiler can now be placed in position
- Slide outer flue box over stainless flue terminal and pass complete assembly through the wall (from out-side)
- Locate stainless steel flue pipe into socket on fixing plate, measure distance from the face of the outside wall to the end of the terminal subtract 140mm this will give the length of pipe to be cut off the flue terminal inner pipe.
- Remove terminal assembly and cut the flue terminal inner pipe down to the length required.
- Slide terminal assembly back through the cut out in wall.
- Re-locate inner pipe over socket on fixing plate (use a small amount of silicone on this joint to form a seal)
- Slide outer flue box back until it locates over the fixing plate (ensure the cut out in the outer flue box is on the R/H as shown in the diagram, and use silicone sealant to ensure a seal).
- Secure in position using 3-No 6 self tapping screws.
- Fit air box gasket over cut out in outer flue box
- Fit air box connector over gasket locating bottom edge in locating bracket and securing in position using -No 6 self tapping screw (see diagram)
- Fit air hose between spigot on burner and spigot on burner and spigot on air box connector using 2 clips supplied.
- Make good around terminal on both sides of wall.
- Replace top casing.

IMPORTANT: Flue Sealing

As the flue system operates under positive pressure, it is essential to seal all flue joints. Apply a thin bead of silicone sealant (supplied) around flue pipe spigot before inserting into socket.

TERMINAL GUARDS

If the terminal guard is less than 2 metres above the ground level, balcony or place to which any person has access, the terminal must be protected by a guard.

2308 240 B/F KIT REAR OUTLET ONLY

ASSEMBLY METHODS

1. Having decided the position of the boiler, cut a hole in the wall to take the balanced flue kit (refer to diagram for dimensional details Fig 12)
2. Remove top casing, remove flue socket & gasket off top of the boiler
3. Place gasket supplied with kit (Item No.1) on top of the boiler, then place top flue box (Item No.10) on top of gasket securing to boiler with 2 M8 flange nuts. (supplied in kit)
4. Slide extension (Item No.2) through wall from the outside of the property inwards until it stops up against the flue box.
5. Measure from the face of the outside wall. to the end of the extension duct add 25mm to the dimension measured. This is the amount which needs to be cut off the extension and the stainless steel tube of the terminal body.
6. Remove extension duct and cut to length. Cut the same amount from the terminal body. (item No.3)
7. Secure flue connector spigot (Item No.4) to the terminal body sealing the joint with silicone sealant.
8. Slide terminal body with connector spigot attached inside extension duct and seal with silicone sealant.
9. Slide the terminal assembly through the wall from the property inwards, using the studs on the end of the terminal secure to the top flue box with 4 M8 flange nuts ensuring that the sealing gasket (Item No.15) is sandwiched between the two.
10. Fit air hose spigot (Item No.6) in position on the terminal assembly using silicone sealant and 3 self tapping screws provided.
11. Fit acoustic air hose between spigot on burner and spigot on terminal assembly. Use 2 jubilee clips provided to secure air hose in position.
12. Fit blanking plate and gasket (Item No.9) to top flue box using 4 M5 X 10 PAN HD screws provided.
13. Make good around terminal on both sides of wall.
14. Terminal guard required if terminal is less than 2 metres from ground level.

2308 240 B/F KIT CASING ASSEMBLY

1. Remove top casing
2. Remove ball studs and serrated washers (Items 5) from side casings and refit into top sides (Items 2 and 6)

NOTE: There is a marker hole in the top side to indicate the front of the panel.

3. Fix top sides to existing side casings using 6 M5 x 10 pozi screws (Item 4)
4. Fit top front panel to top sides using 4 M5 x 10 pozi screws (Item 4)
5. Refit top panel.

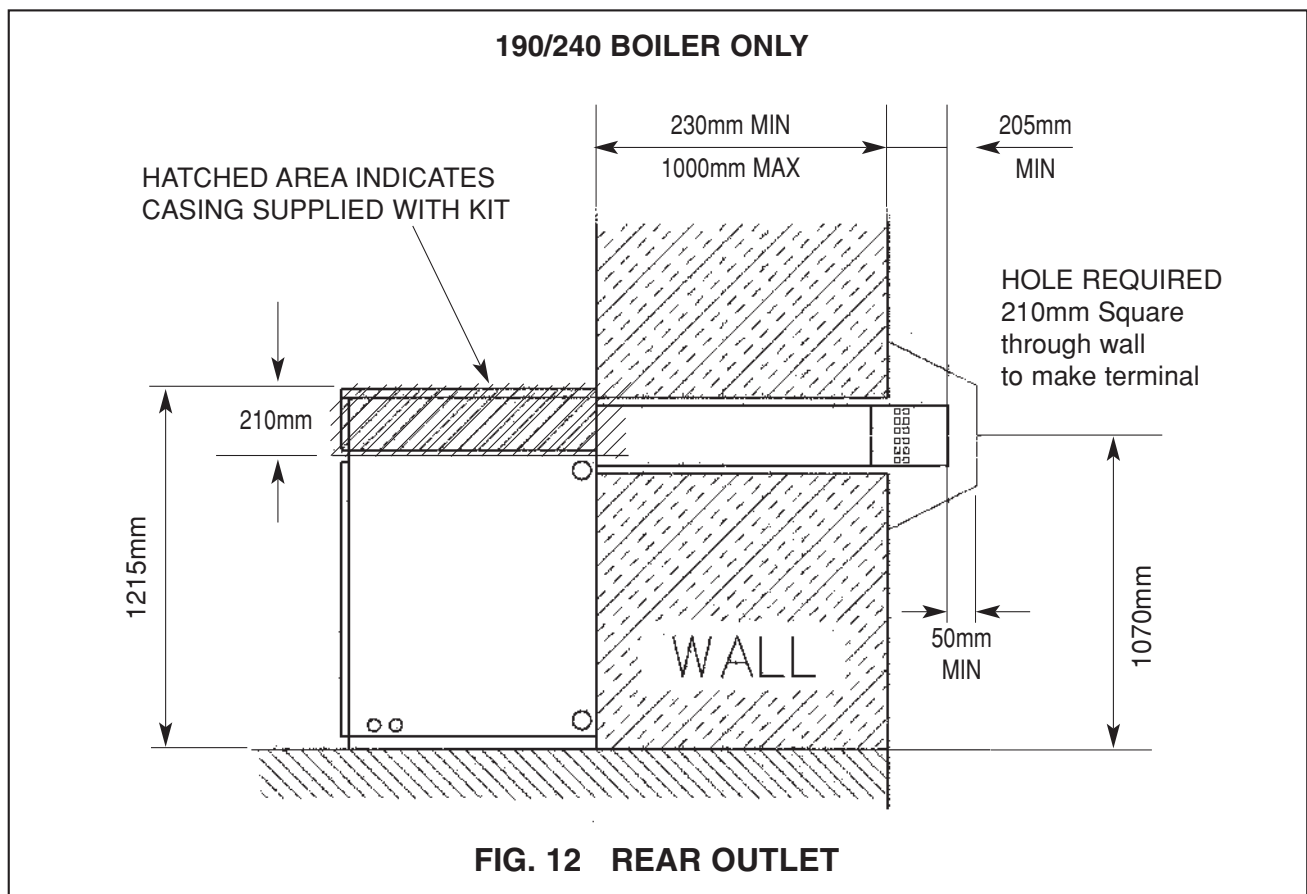

**190/240 BOILERS ONLY
(KIT 2308)**

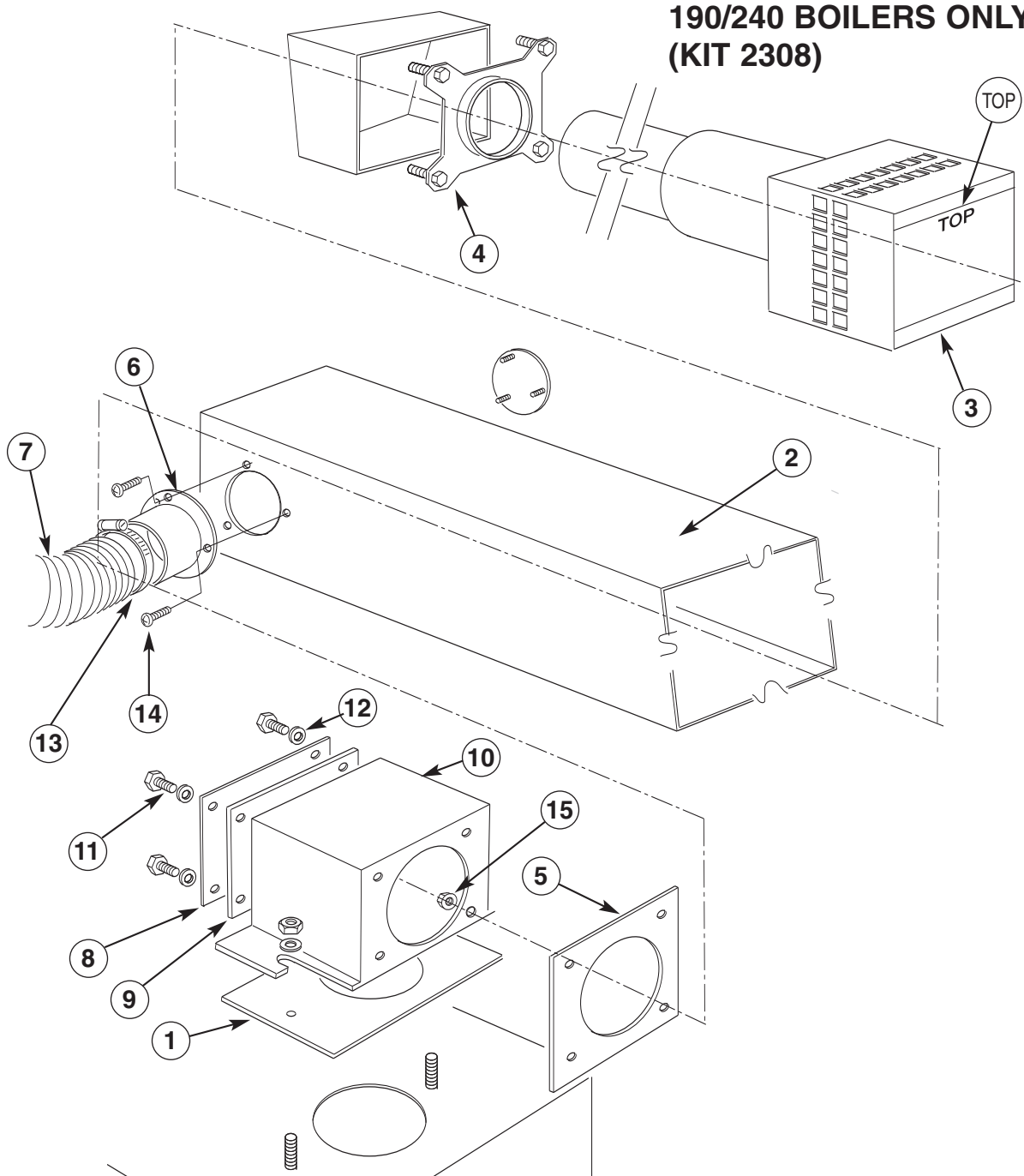

| Item | Description | Part no. | No. Off |
|------|------------------------------|----------|---------|
| 1 | Boiler top gasket | 209579 | 1 |
| 2 | Extension W.V. | 209570 | 1 |
| 3 | Terminal silencer | 209560 | 1 |
| 4 | Flue connector spigot plate | 209572 | 1 |
| 5 | Blanking plate gasket | 209577 | 1 |
| 6 | Air box hose spigot | 209583 | 1 |
| 7 | Air hose acoustic | 209576 | 1 |
| 8 | Blanking plate | 209578 | 1 |
| 9 | Blanking plate gasket | 209577 | 1 |
| 10 | Boiler top flue box assembly | 209575 | 1 |
| 11 | MS x 20 Hex head screw | 91187 | 4 |
| 12 | MS washer | 92189 | 4 |
| 13 | Jubilee clip | 95256 | 2 |
| 14 | Self tapping screw | 91523 | 3 |
| 15 | M8 flange nut | 94396 | 6 |

FIG. 11 190/240 BALANCED FLUE KIT EXPLODED VIEW

190/240 BOILERS ONLY

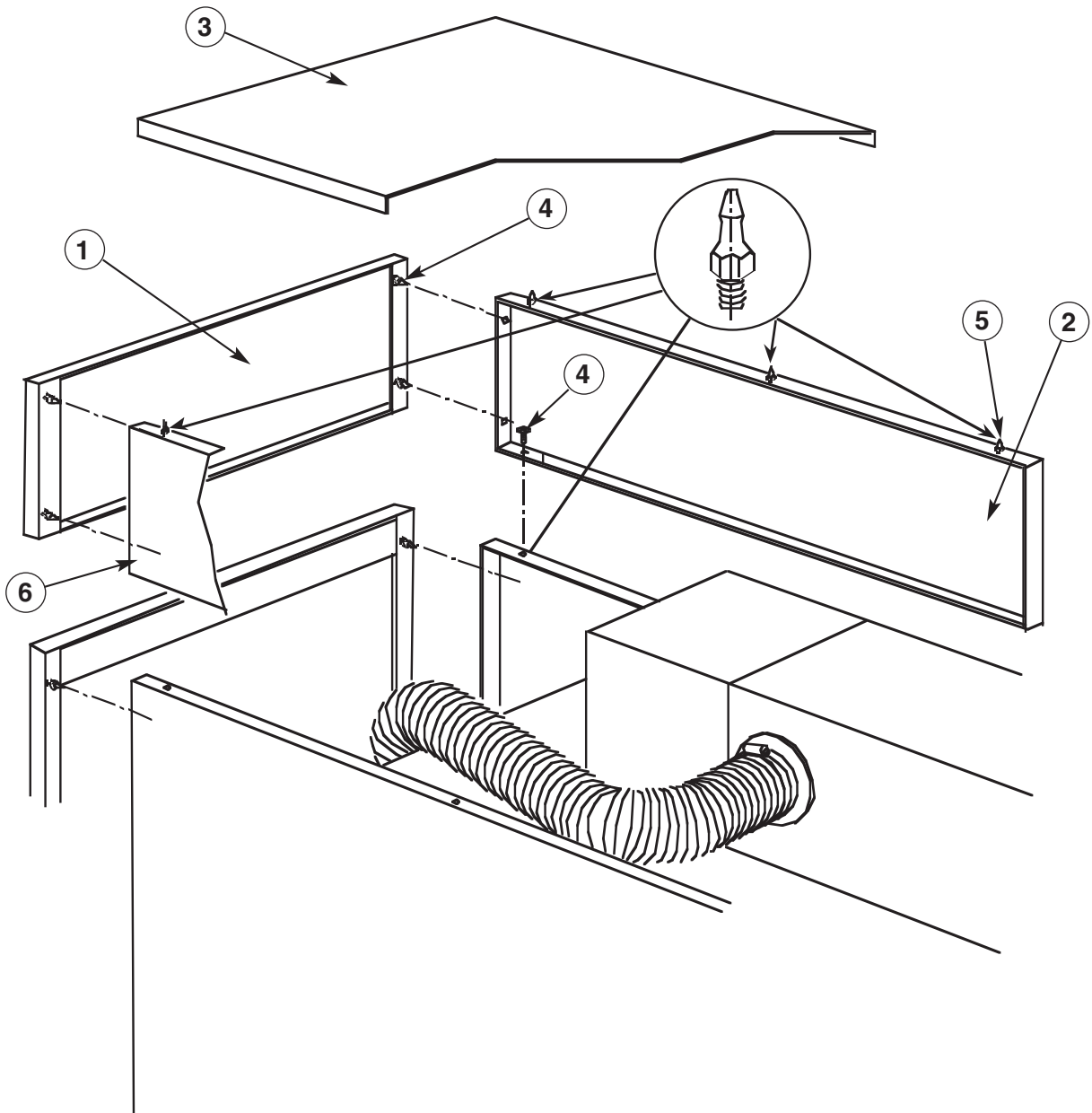

| Item | Description | Part no. | No. Off |
|------|---|----------|---------|
| 1 | Front panel assembly | 209587 | 1 |
| 2 | Side casing assembly L/H. | 209585 | 1 |
| 3 | Top casing Ass'y (supplied with boiler) | 209270 | 1 |
| 4 | MS x 10 pan head pozi's | 91184 | 14 |
| 5 | Brass ball stud (supplied with boiler) | 95215 | 6 |
| 6 | Side casing assembly R/H. | 209580 | 1 |

FIG. 13 190/240 BALANCED FLUE KIT CASING EXPLODED VIEW

7. COMMISSIONING

The boiler/burner must be commissioned by an OFTEC trained and registered engineer.

It is the responsibility of the installer to ensure the boiler is properly commissioned, failure to do so will make the guarantee and any extended warranty null and void.

Although all burners are factory tested before despatch, they will usually need further air adjustment to achieve the readings indicated in 'Burner detail leaflet' because of site variations in flue draught and back pressure.

Procedure

1. Switch off electrical supply to the boiler.
2. Ensure boiler is full of water and all valves are open.
3. Remove flue-cover and check that flue-baffles are correctly positioned (See Fig 15 for baffle arrangement).
4. Disconnect oil hose from burner, open shut-off valve and run off a quantity of oil into a container to check for a clean air free supply then reconnect hose. (This applies to single pipe gravity system only).
5. Check that the time-switch (if fitted) is in the ON position and room and boiler thermostats are calling for heat.
6. Switch on electrical supply and the burner should start.

Note: The burner may lock-out on first firing due to air in the pump, if this happens, wait about a minute before pressing reset button to restart burner. If a further lock-out occurs, the air should be bled from the pump pressure gauge connection.

7. Start and stop the burner two or three times until the flame cuts off sharply - this indicates any remaining air has been dispersed.
8. All the burner to run for about 15 minutes, then take a CO₂ reading through the sampling hole in flue-cover. Compare the reading with that given under 'Burner Settings' and adjust the air setting if necessary to achieve the required CO₂%. Also, check the smoke and flue gas temperature.

Handing Over

After completing the boiler installation, the installer should make a thorough check of the system to ensure it is completely satisfactory and demonstrate to the user the operation of the boiler and any system controls.

All instructions should be handed to the user for retention and advice regarding the need for annual servicing.

8. SERVICING

To maintain the boiler's high thermal efficiency and reliable operation, it should be serviced annually by a qualified engineer preferably OFTEC trained and registered.

Note: It is a requirement of the boiler's guarantee that an annual service is carried out by a qualified engineer.

If the boiler is used to provide central heating and hot water all year round, the best time for its annual service is just before the start of the heating season.

Where the boiler is shut down for the summer months, the service should be carried out as soon as possible after the end of the heating season.

Oil tank

Open tank drain-cock to draw off any accumulated water and sludge.

Line filters

Turn off oil supply and remove filter bowl. Wash filter element clean with kerosene.

Servicing the Boiler (Burner removed)

1. Remove flue-cover and lift out flue-baffles
2. Brush all deposits from flue-baffles and internal surfaces of the boiler.
3. Remove flue deposits from the combustion chamber floor using a vacuum cleaner.
4. Replace flue-baffles in the correct arrangement (See Fig. 15 for order of assembly). Re-fit the flue-cover and fully tighten wing-nuts to make a gas tight seal.
5. Refit burner to boiler in reverse order to removal.
6. Turn on oil supply, switch on electricity and burner should fire.
7. Finally check the combustion readings with those given under 'Burner Settings' and make any air or oil pressure adjustments necessary.

FIG. 15 EuroStar Baffle Arrangement

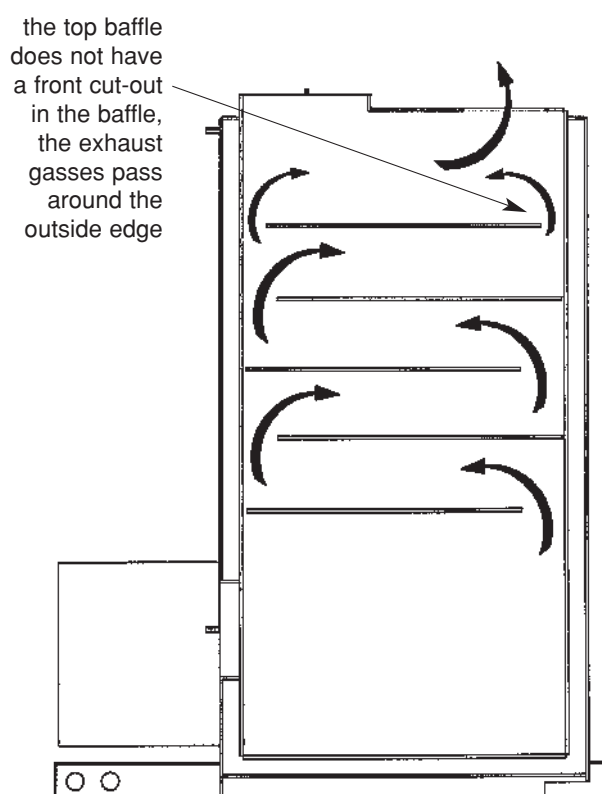

BAFFLE POSITIONS

When replacing baffles ensure cut outs in the baffles are positioned as shown.
This will allow the correct flow of exhaust gas.

9. FAULT FINDING

ELECTRICITY SAFETY - Before making any electrical checks, switch off mains supply to boiler.

| FAULT | POSSIBLE CAUSE | ACTION |
|--|--|---|
| BURNER WILL NOT START | Control box locked out | Press reset button on front of burner. N.B. ONLY TRY TWICE |
| | Limit-stat tripped | Press reset button under control panel and check function of boiler control thermostat. |
| | Boiler thermostat or other system controls satisfied | Ensure all controls are calling for heat. |
| | Fuse blown | Fit new 5 amp fuse, if it blows again, check for short circuit in wiring. |
| | Check for live supply continuity up | If live supply confirmed, change control box to burner |
| | Motor or pump seized | Check for rotation and replace as necessary. |
| BURNER STARTS BUT FLAME NOT ESTABLISHED | No oil supply | Check oil level in tank and feed to burner. |
| | Photo-cell not seeing flame | Clean photo-cell and ensure it is fully plugged in. |
| | Air trapped in pump | Bleed off air through pressure gauge tapping. |
| | Solenoid valve faulty | Check coil for continuity and replace if faulty. |
| | Nozzle blocked | Replace nozzle with one of same specification. |
| | Electrodes incorrectly set | Reset gap and position electrodes as shown in Burner diagram. |
| | Electrode insulator cracked | Check and replace if insulator cracked or crazed. |
| | Ignition transformer and H.T. leads faulty. | Check for spark and condition of H.T contacts. Replace as necessary. |
| FLAME ESTABLISHED BUT BURNER LOCKS OUT AFTER FEW SECONDS | Low oil pressure | Check pump pressure and adjust to correct setting. |
| | Oil contaminated with water | Run off oil at burner until free of water and drain condensation from tank |
| | Oil filter partially blocked | Wash filter clean with kerosene. |
| | Photo-cell fault | Clean photo-cell and ensure it is fully plugged in. Replace if faulty. |
| | Oil pressure low | Check pump pressure and adjust to correct setting. |

FAULT FINDING (Cont'd)

| FAULT | POSSIBLE CAUSE | ACTION |
|---|--|---|
| POOR FLAME CUT-OFF | Air in pump or at back of nozzle | Bleed pump through pressure gauge port, also check for leaks in oil line if 2-pipe system. |
| | Oil contaminated with water | Run off oil at burner until free of water and drain condensation from tank. |
| | Dirt in solenoid valve | Clean or replace valve. |
| | Pump shut-off piston sticking | Replace pump. |
| MORNING START LOCK-OUT | Faulty non-return valve or air leak | Replace non-return valve and cure leak. in two pipe system |
| | Low voltage | Check with local Electricity Board. |
| | Combustion readings incorrect | Check combustion under normal running conditions and compare readings with those given under 'Burner Settings'. |
| | Oil level in tank falling below burner | Raise tank or fit a 2-pipe system. |
| DELAYED IGNITION- BURNER PULSATES ON START UP | Nozzle partially blocked | Replace nozzle |
| | Oil pressure too low | Check and recommission |
| | Flue blocked or damaged | Check and rectify |
| | Fan slipping on shaft | Check and retighten |
| | Pump coupling loose or worn | Check and replace |
| BURNER STARTS VIOLENTLY | Delayed ignition | Check electrode setting and adjust to correct gap |
| | | Check electrodes for damage |
| | | Check H.T. leads for damage and positive connection |

10. SPARES

EuroStar Boiler Parts

| Item | Description | No. Off | 130/150 | 160/180 | 190/240 |
|------|-----------------------------|---------|---------|---------|---------|
| 1 | Boiler Body WU | 1 | 222260 | 222260 | 222290 |
| 2 | L/H Side Casing Assembly | 1 | 222011 | 222011 | 222011 |
| 3 | R/H Side Casing Assembly | 1 | 222010 | 222010 | 222010 |
| 4 | Top Casing Assembly | 1 | 222012 | 222012 | 222012 |
| 5 | Door Casing Assembly | 1 | 222013 | 222013 | 222013 |
| 6 | Flue Cover Assembly | 1 | 209320 | 209320 | 209320 |
| 7 | Control Box Assembly | 1 | 207891 | 207891 | 207891 |
| 8 | Control Panel | 1 | 221918 | 221918 | 221918 |
| 9 | Limit Thermostat | 1 | 206892 | 206892 | 206892 |
| 10 | Boiler Thermostat | 1 | 206896 | 206896 | 206896 |
| 11 | Burner Assembly | 1 | 221380 | 221400 | 221410 |
| 12 | Burner Gasket | 2 | 208799 | 208799 | 208799 |
| 13 | Bottom Baffle 130/240 | 8 | 209280 | 209280 | 209280 |
| 14 | Top Baffle 130/240 | 2 | 209282 | 209282 | 209282 |
| 15 | Flue Collector Box Assembly | 1 | 209340 | 209340 | - |
| 16 | Casing Bracket | 1 | 209255 | 209257 | 209257 |
| 17 | Back Panel | 1 | 221998 | 221998 | 221998 |

EUROSTAR 130/150, 160/180, and 190/240

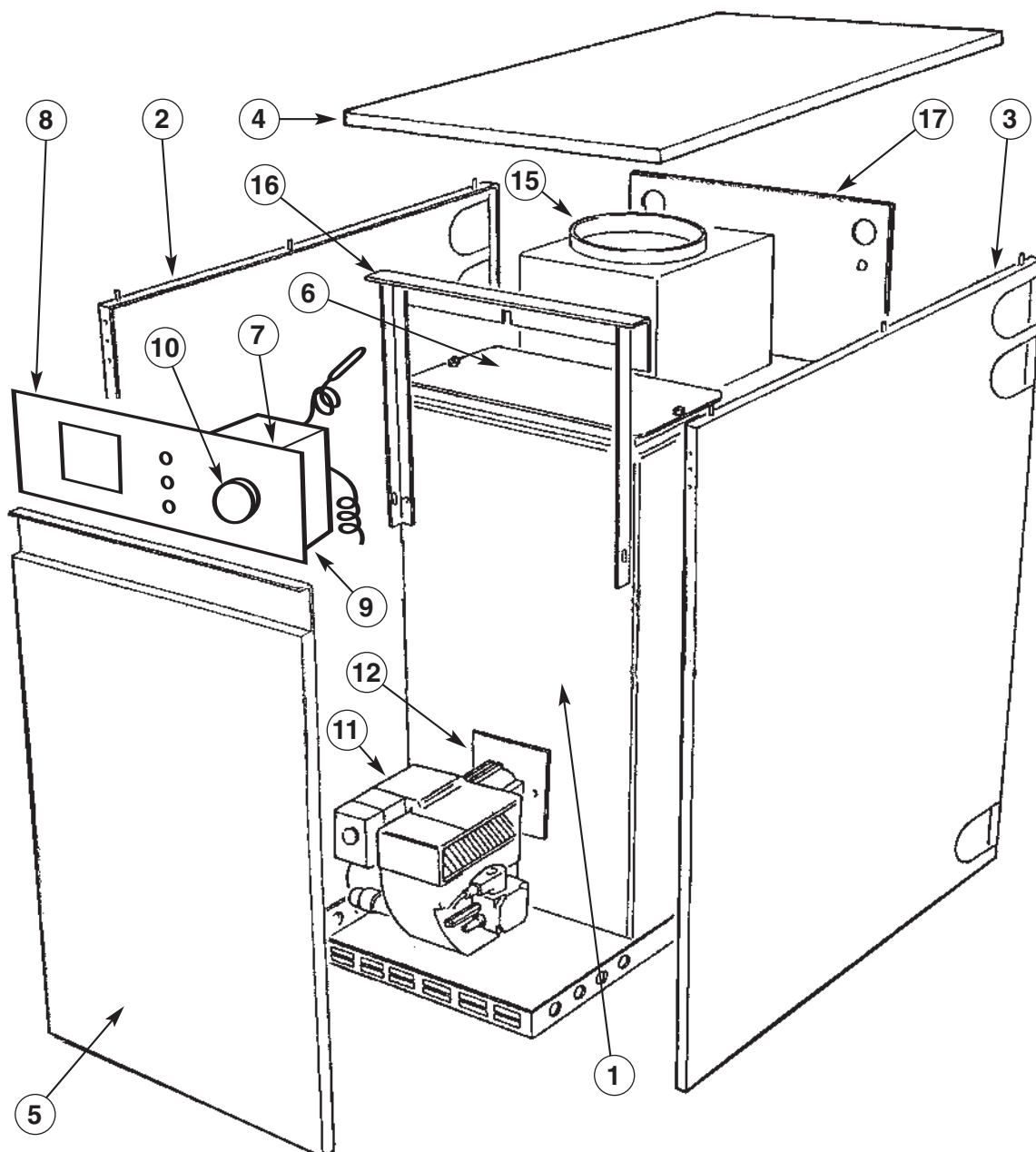

EuroStar 130/150, 160/180 & 190/240

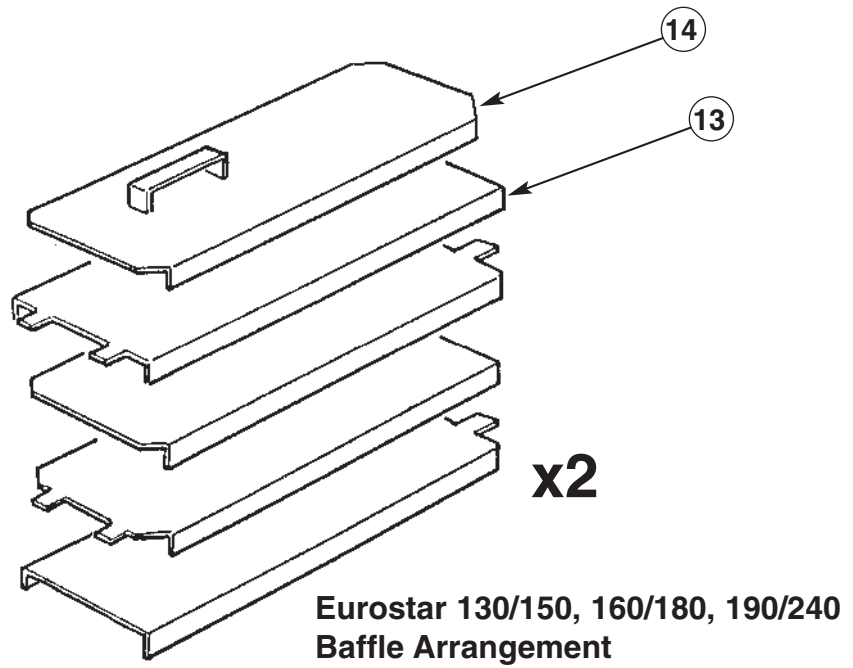

| ITEM | PART NO | NO OFF |
|------|---------|--------|
| 13 | 209282 | 2 |
| 14 | 209280 | 8 |



By appointment to H.M. Queen Elizabeth
The Queen Mother
Manufacturers of Domestic Boilers



TRIANCO LIMITED
Thorncliffe, Chapeltown, Sheffield S35 2PZ
Tel: Sheffield (0114) 257 2300
Fax: (0114) 245 3021
www.trianco.co.uk



© Trianco Limited, Copyright in this brochure and the drawings or illustrations contained in it is vested in Trianco Limited and neither the brochure or any part thereof may be reproduced without prior written consent.

Trianco Limited's policy is one of continuous research and development. This may necessitate alterations to this specification.