

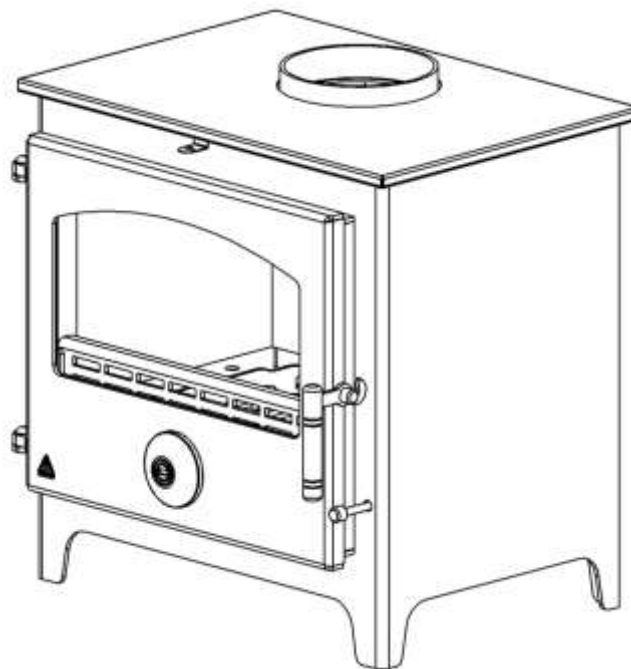

## **Newton Multi Fuel 8kW Space Heating Stove**



---

### **OPERATION, INSTALLATION, COMMISSIONING & SERVICING INSTRUCTIONS**

---

**Please read these instructions carefully before installing,  
Commissioning and using this appliance.**

**TO BE RETAINED BY THE HOUSEHOLDER**

---

## HEALTH AND SAFETY

---

### INFORMATION FOR THE USER, INSTALLER AND SERVICE ENGINEER

Under the Consumer Protection Act 1987 and the Health and Safety at Work Act 1974, it is a requirement to provide information on substances hazardous to health (COSHH Regulations 1998).

TR Engineering takes every reasonable care to ensure that its products are designed and constructed to meet these safety requirements when the products are properly installed and used. To fulfil the requirements, products are comprehensively tested and examined before despatch.

When working on the appliance, it is the responsibility of the user or engineer to ensure that personal protective clothing or equipment appropriate to parts that could be considered hazardous or harmful is worn.

This appliance may contain some of the items below:

#### **Insulation and Seals**

Glass rope, mineral wool, insulation pads, ceramic fibre, glass insulation.

When handling, avoid inhalation and contact with eyes. These may be harmful and cause irritation to the skin, eyes, nose or throat. Use disposable gloves, facemasks and eye protection.

After handling, wash hands and other exposed areas. When disposing of materials, limit dust and the risk of inhalation by using a water spray. Ensure materials are securely wrapped.

Seek urgent medical attention if inhaled or ingested. Exposure to eyes and skin should be followed by immediate cleansing of the affected areas and medical attention if necessary.

#### **Glues, Sealants and Paints**

The glues, sealants and paints used present no known hazards when the appliance is used in the manner for which it is intended.

#### **Handling**

Adequate facilities must be available for loading, unloading and site handling.

#### **Fire Cement**

Some types of fire cement are caustic and should not be allowed to come into contact with the skin. In case of contact wash immediately with plenty of water.

#### **Asbestos**

This stove contains no asbestos. If there is a possibility of disturbing any asbestos in the course of installation then please seek specialist guidance and use appropriate protective equipment.

CONTENTS	Page no.
Important Notes	4
Operation	5
Using the stove	5 - 6
Recommended fuels	7 - 8
Troubleshooting and maintenance	8
After-sales advice	9
Installation	10
Regulations / Health & safety / Preparation	10
Siting	11
Technical details	11
Chimneys / flues	12 - 13
Air supply	14
Fuel conversion	14
Commissioning	14
Servicing	15
Procedure	15
Spares	15

## **IMPORTANT USER NOTES**

### **CO Alarms:-**

**Building regulations require that whenever a new or replacement fixed solid fuel or wood/biomass appliance is installed in a dwelling a carbon monoxide alarm must be fitted in the same room as the appliance. Further guidance on the installation of the carbon monoxide alarm is available in BS EN 50292:2002 and from the alarm manufacturer's instructions. Provision of an alarm must not be considered a substitute for either installing the appliance correctly or ensuring regular servicing and maintenance of the appliance and chimney system.**

### **Warning Note**

Properly installed, operated and maintained this stove will not emit fumes into the dwelling. Occasional fumes from de-ashing and re-fuelling may occur. However, persistent fume emission is potentially dangerous and must not be tolerated. If the fume emission does persist, then the following immediate action should be taken:-

- a) Open doors and windows to ventilate the room and then leave the premises.
- b) Let the fire go out.
- c) Check for flue or chimney blockage and clean if required.
- d) Do not attempt to relight the fire until the cause of the fume emission has been identified and corrected. If necessary seek expert advice.

The most common cause of fume emission is flue way or chimney blockage. For your own safety these must be kept clean at all times.

Your installer should have fitted a CO alarm in the same room as the appliance. If the alarm sounds unexpectedly, follow the instructions given under "Warning Note" above.

Do not use aerosol sprays near the stove when it is alight.

### **Extractor Fans:-**

Do not fit an extractor fan in the same room as this stove as this may cause the stove to emit fumes into the room.

**Where the chimney is believed to have served an open fire installation it is possible that the higher flue gas temperature from a closed appliance may loosen deposits that were previously firmly adhered, with the consequent risk of flue blockage. It is therefore recommended that the chimney be swept a second time within a month of regular use after installation.**

## INTRODUCTION

The Newton Multi-fuel stove has been designed and constructed to give years of trouble-free domestic space heating. These instructions are provided to assist you in obtaining the best performance with the least trouble and cost.

To help us provide the highest levels of customer service, it is important that the registration card is completed in full and returned. To ensure you have a clear understanding of the appliance, please take the time to read these instructions.

The stove must be installed by a qualified engineer. Routine cleaning can be carried out by the end user, but the stove should be fully serviced, and the chimney swept, on an annual basis by an approved engineer. Keep all ventilation installed for use with the stove open and clear of obstructions.

Do not put combustible materials close to the stove. Its surface will become very hot during burning, so a suitable fireguard should be used. Some household items, such as photographs, paintings or television screens, may be susceptible to damage from rapidly-fluctuating air temperatures; as such, do not place them above the stove area, where high-temperature air will circulate.

Do not use third-party spares with the appliance, or make unauthorised modifications to its design. The stove must not share a chimney with another appliance.

## OPERATION

Before using the stove, check that the chimney is clear and has been confirmed for soundness. Operate the stove at low outputs for the first few days for glue and paint curing; some odours may be given off during this time, so keep the building well ventilated.

### Solid fuels

Ensure the stove is set to burn solid fuel. The bottom grate assembly, fire bricks, throat plate, front grate and ash pan must all be present (see **fig 6** for assembly).

Note: on cold days it may be necessary to warm the flue using two firelighters. Procedure:

- Place firelighters, or a liberal coating of kindling material (wood/paper, light paper) among a small quantity of fuel in the combustion chamber.
- After lighting, set the air regulator wheel to maximum and the air wash to about 50%. To prevent condensation build-up, leave the door partially open until the glass has warmed.
- With the fire established, open the fire door and fill the combustion chamber to the top of the front grate, sloping upwards to the rear of the chamber.

Close the fire door and ensure it is locked. For best efficiency, set the air wash to about 25% and control burning using the air regulator wheel.

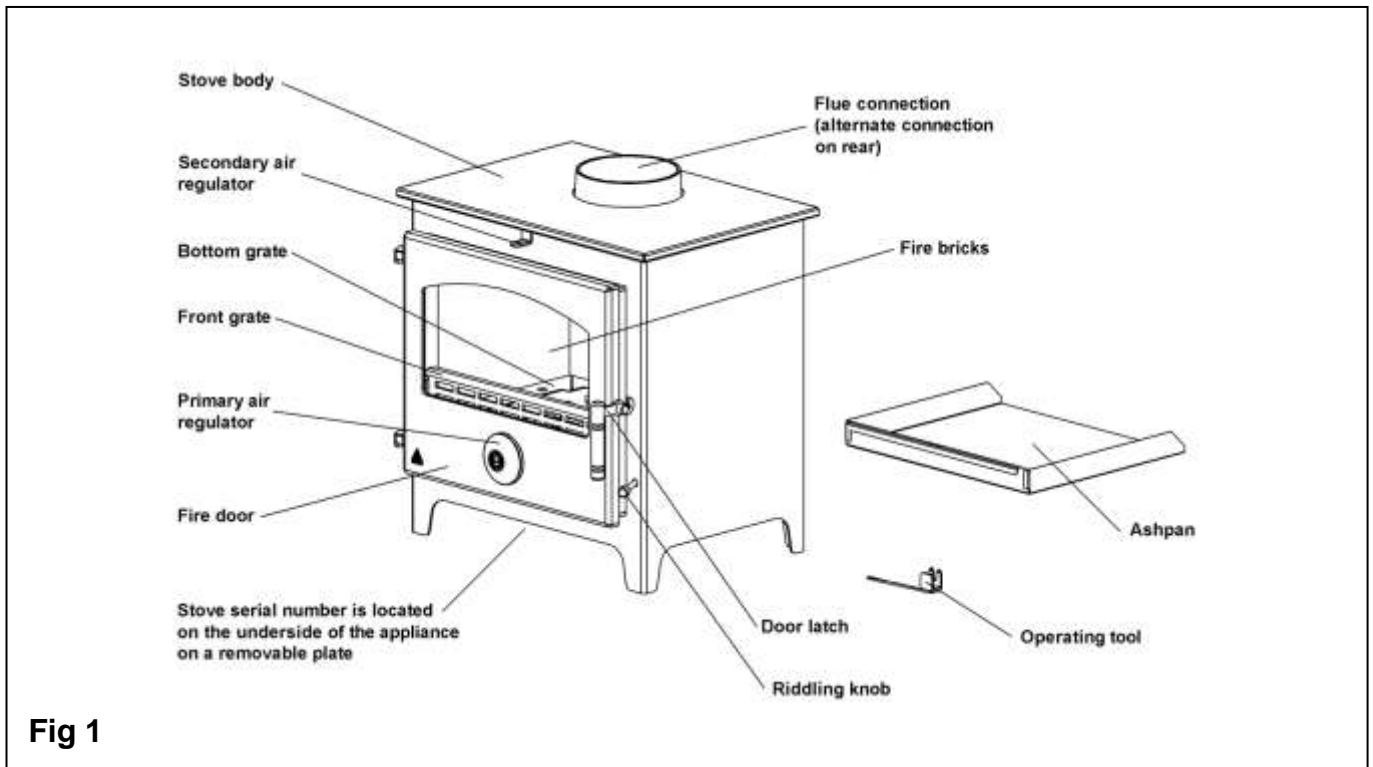

**Fig 1**

The highest burning rate is achieved by opening the air regulator wheel to maximum. Excess ash formation may indicate over firing.

- For overnight or daytime slow burning, set the air regulator wheel to be open by one full turn. Experience will determine the settings that produce best results.

Overnight burning can also be obtained by:

- a) Using smaller fuel
- b) De-ashing prior to refueling
- c) Position of damper if fitted
- d) condition of fire-bed before refuelling

When refueling, first de-ash the fire bed:

- Riddle the bottom grate by engaging the operating tool on the riddling knob. Pull and push sharply for about 10 strokes, after which the fire should be free of ash.
- Open the locked fire door with the operating tool and use the tool to remove the ash pan.
- Empty the ash-pan at regular intervals; do not allow ash to accumulate to the level of the bottom grate, as it may cause damage over time.
- The presence of shale, stone or clinker in the fire bed will reduce burning rates; to remove, rake the fire upwards with a poker to bring the material to the top, where it can be removed with tongs.

To add fuel:

- Turn the air regulator wheel to fully open; this will establish a bed of hot fuel, onto which new fuel can be placed.
- Allow the stove to burn at maximum output for a few minutes before setting the air regulator wheel to the desired position.

The stove should be allowed to burn at maximum output for around 30 minutes per day.

### **Bituminous fuel**

Follow the procedure set out for lighting solid fuels, plus:

- Always refuel to the maximum limit (i.e. to the top of the front grate, sloping upwards to the rear).
- The fire door must be left slightly ajar until the bed of fuel has flames passing through it.

- If the door is closed too early, small explosions can force smoke through the door seals or air inlet into the room being heated.
- Do not operate the stove for long periods, or leave it unattended, with the door open; doing so can damage the stove.
- When bituminous fuel is used, the fire door glass will have to be cleaned more frequently.

### **Wood**

Ensure the stove is set to burn wood. The bottom grate assembly, fire bricks, throat plate, front grate and ash pan must all be present (see **fig 6** for assembly).

- Add a liberal amount of paper and small pieces of wood kindling. Place two smaller logs on top and light the paper/kindling. Chemicals or fluids should not be used to start the fire.
- After lighting, set the air regulator wheel to maximum, and the air wash to about 25%. To prevent condensation build-up, leave the door partially open until the glass has warmed.
- With the fire established, open the fire door and fill the combustion chamber to the top of the front grate, sloping upwards to the rear of the chamber.
- Close the fire door fully and ensure it is locked. Allow the stove to burn at maximum output for a few minutes before setting the air.
- The highest burning rate is achieved by opening the air regulator wheel to maximum. For best efficiency, close the air regulator wheel and control the burning rate with the air wash.
- For daytime slow burning, set the air regulator wheel to be open by one full turn. Experience will determine the settings that produce best results.
- Firing the stove at very low outputs for long periods will increase creosote build-up and reduce the effectiveness of the air wash.

To add fuel:

- Open the locked fire door with the operating tool and rake the embers over the fire bed.
- Turn the air wash too fully open; this will establish a bed of hot fuel, onto which new logs can be placed.
- Allow the fire to burn for a few minutes before setting the air wash to the desired position.

The stove should be allowed to burn at maximum output for around 30 minutes per day; this will help prevent creosote build-up.

### **Disposal of ashes**

The periodic removal of ashes will be required; the time between de-ashings will be determined by the type of fuel used and how much the stove is used. Solid fuel ash will need to be removed more frequently than wood ash.

When burning solid fuel, allow the fire to burn low or go out before removing the ash pan using the tool provided.

When burning wood, allow the fire to go out and cool. Remove the front grate and remove the ash with a metal shovel. It is usually advisable to leave a 12.5 mm (½") layer of ash in the bottom of the combustion chamber for future lighting.

Ashes should be placed in a non-combustible container. Before the ashes are disposed of, ensure they have thoroughly cooled. Ashes may contain dormant coals, which can burn for several hours after a recognisable flame has disappeared. No other waste should be placed in the container. Use extreme caution when handling and disposing of ashes.

### **Safety advice**

Always use an approved fireguard in the presence of children, and old and/or infirm people. The fireguard should be manufactured in accordance with BS EN 8423:2002, Fireguards for use with solid fuel appliances.

Occasionally, fumes may be detected during refueling and de-ashing, but during normal running the stove should not emit fumes into the room being heated. See **page 7** for troubleshooting.

### **FUELS**

Manufactured and natural smokeless fuels are recommended for use with the stove. Outside smoke control areas, bituminous coal briquettes, wood logs and peat blocks may be used.

For a full list of suitable fuels, check with the official solid fuel approvals body, HETAS, or the Solid Fuel Association. Only use fuels approved for use with closed heating stoves. Refer problems about fuel quality or suitability to the fuel supplier.

Do not burn liquid fuels, driftwood, manufactured logs (e.g. compressed wood), varnished or plastic-coated wood, wood treated with preservatives, or household waste.

### **Smokeless fuel**

The stove is suitable for use with manufactured and natural smokeless fuels that have been approved for use

with closed heating stoves. Bituminous coal briquettes may be used, but petroleum coke must not.

### **Wood burning – types of wood**

Wood logs and peat blocks may be used, but only outside smoke control areas. The stove will burn most well-seasoned softwoods and hard woods. Softwoods are usually easier to light than hard woods, but the latter will produce less ash, soot and creosote residue, and will burn for longer. Types of hard wood include beech, ash and oak.

Ensure wood has been seasoned correctly. Seasoning can take up to 18 months, depending on the tree species, when it was felled, and the drying conditions. Logs can have their seasoning accelerated by being forced dried in a kiln.

The thermal value of wood depends on its moisture content. As the moisture content increases, the useful energy derived from its burning decreases. This is because energy is used to drive off the excess moisture. Ensure the wood has a moisture content of less than 20%. Assuming 20% moisture content, 1 kg of wood will have a thermal value of about 4 kWh.

Wood that has not been split and left for a period will contain more moisture. This will reduce the efficiency of the appliance and result in higher fuel consumption. Wood that contains too much moisture also produces more steam and may contribute to incomplete combustion. This can lead to an excess of creosote build-up.

### **Wood burning storage**

When wood has been cut to an appropriate length and split, it should be stored in a dry area. Stack the logs to expose both ends to the air, as more drying occurs from the ends than the sides. This holds even for wood that has been split. The woodpile should be under cover to prevent its absorbing moisture from rain or snow, but should still be open on the sides to be subject to the drying effect of sun and wind.

Do not store the wood within the installation clearances of the appliance, or within the space required for loading or ash removal.

To reduce the impact on the environment, select a local supplier as this reduces the energy required to transport the fuel. Where possible, ensure wood comes from a sustainable source. Buy logs by volume rather than weight, as the influence of moisture content is removed from the calculation.

## Wood burning creosote build-up

Wood combustion is never 100% complete, wood smoke always contains some unburned material. A little of this will condense on a cool surface, leaving a dark brown or black substance that has an acrid odour. This substance is commonly called creosote. If the exhaust gases condense on cool surfaces such as a cold chimney, they will retain large amounts of water. At higher temperatures, the condensed creosote will resemble tar.

Creosote generation is highest during low heat outputs common with long, smouldering burns. Creosote generation is lowest during high heat outputs common with intense fires. For best results against creosote build-up, it is recommended that a small, intense fire be used, even though refuelling may need to take place more often.

Creosote generation is also higher when burning wood with a high moisture content, such as green wood. The moisture in the wood absorbs heat from the fire, cooling it below the point at which the creosote can be consumed. The low-temperature smoke is then cooled further in the chimney.

To reduce the likelihood of creosote build-up during periods of low heat demand, it is recommended to fuel the boiler with lower quantities of smaller diameter logs. Matching fuel loads and heat requirements will result in cleaner combustion and higher efficiency.

## TROUBLESHOOTING

If a fire occurs in the chimney, immediately close the air regulator wheel and air wash to cut off the fire's oxygen supply. Evacuate the building and call the fire services; do not use the stove until it has been certified safe by a qualified HETAS engineer, any necessary repairs have been made, and the chimney has been swept.

If smoke collects inside the building, close the air regulator wheel and air wash. Open windows and doors to allow the smoke to escape. Do not use the stove until the source of the problem has been repaired.

### Fuel quality

Poor quality fuel can lead problems lighting the stove or maintaining a steady burning rate, poor flame with excess smoke, excess dirt build-up, or staining, on the glass and inside the combustion chamber, and reduced life spans for the internal components, such as fire bricks and bottom grate.

When burning wood, in addition to the above, wet fuel may cause excess creosote build-up in the flue and discoloured chimney smoke.

## Flue draught

The flue must operate under pressure that is, there should be a constant "pull" up the chimney to allow the hot flue gases to escape safely. The flue draught can be affected by structures that are too close to the flue termination, extreme winds extreme temperatures, incorrect combustion air, a blocked flue or incorrectly-sized flue. Ensure the required ventilation openings are kept permanently free of obstructions.

If fuel consumption is too high or overheating occurs, these may be caused by excessive flue draught. If the fire will not light or maintain a steady burning rate, if the heat output is too low, or smoke remains in the combustion chamber, these may be caused by inadequate flue draught.

### Blow-back

Blow-back small explosions that force air through the fire door seals or air controls is caused by inadequate combustion air; for example, if the door is closed too early or the air regulator wheel and air wash are not open wide enough after adding new fuel.

## MAINTENANCE

Before cleaning the stove, ensure it has fully cooled.

Routine maintenance can be carried out by the end user. The throat plate should be removed and cleaned monthly. The flue pipe can be cleaned by using a flexible brush. Only use a damp sponge for external surfaces. Over time, the fire door glass may become dirty; to clean, wipe with a damp cloth and polish with a dry one.

The stove should be fully serviced and the chimney swept on an annual basis by qualified engineers.

It may eventually become necessary to re-coat the matt black external surfaces of the stove; always use a paint or spray specifically designed to withstand high temperatures.

The ideal time for servicing is just after the end of the heating season, as the stove will not be in use. While dormant, the stove should be emptied of ash and fuel, and left with the air regulator wheel and air wash open; this will help prevent condensation build up, which can reduce the stove's life expectancy.

After a prolonged shutdown, the flue should be checked for blockages before use.

Do not modify the appliance; only use spares authorised by the manufacturer.



## AFTER-SALES SERVICE INFORMATION

A qualified field service engineer is available to attend a breakdown occurring during the stove's guarantee period.

The stove must be made available for attendance during normal working hours, Monday to Friday.

### How to report a fault

#### Step 1

Contact your installation or service engineer, who should assess the unit and works carried out on the appliance prior to requesting the attendance of an engineer from TR Engineering.

#### Step 2

**Please note that upon attendance by an engineer, a charge will be made where:**

- The engineer finds no fault with the stove.
- The cause of the breakdown is due to parts of the system not supplied by the manufacturer.
- The cause of the breakdown is due to incorrectly fitted spare parts, or third-party spares not designed for use with the stove.
- The appliance has not been installed and commissioned by a qualified engineer as described in these instructions.
- The stove has not been serviced annually since installation.
- The breakdown occurs outside the guarantee period.
- The appliance has not been maintained correctly.
- The breakdown occurs due to use of the appliance not sanctioned by these instructions.
- The breakdown occurs as a result of work on the appliance by an unauthorised third party.

### Important:

**Invoices for attendance and repair work by any third party will not be accepted unless authorised in advance by TR Engineering Ltd.**

### Technical Assistance

A team of trained technical advisors is available to discuss any problem with the appliance. In many cases, the problem may be solved over the telephone, eliminating the need for an engineer's visit.

Before making contact, please have the following information ready:

- The appliance serial number or your unique customer identification number (issued upon registration of the appliance). The serial number is located on the underside of the stove, at the front.
- A description of the fault and any unusual behaviour by the appliance before the failure occurred.
- The installation and commissioning dates, and the details of any annual services.

Appliance Serial No.: _____
Cust. ID No.: _____
Installation Date: ____/____/____

### Important note:

Over 50% of all service calls are found to have no appliance fault.

## Service Centre and Technical Support

Tel: 0114 257 2300

Fax: 0114 257 1419

### Hours of Business

Monday–Thursday: 8:30am – 17:00pm

Friday: 8:30am – 14:30pm

## INSTALLATION

### Regulations

The Newton Multi fuel must be installed by a competent person, preferably HETAS registered. Follow the requirements of all relevant Building Regulations. The installation must comply with all other local, national and European regulations and standards that may apply. Where the regulations conflict with information in this manual, follow the advice of the former.

The installation engineer should be aware of his or her responsibilities under the Health and Safety at Work Act and provide where necessary appropriate protection for all persons carrying out the installation.

### Preparation

Before assembling the stove, ensure all packaged parts have been removed from inside. Inspect the stove to ensure no damage has occurred during transit. Ensure all parts have been provided (see **fig 7, page 13**).

### Siting

Before installation, ensure the building has a load bearing rating sufficient for the stove's weight. Suitable measures (e.g. a load distributing plate) should be taken if inadequate. The stove should be placed on a non-combustible hearth that adheres to the clearances in **fig 2 & 3**.

The stove can be installed in a recess if the hearth is level and, with the adjacent walls, conforms to current Building Regulations. The size of the recess is determined by the types of material used.

Always leave access for future cleaning and servicing of the stove, flue socket and flue.

The stove, recess hearth and chimney installation should conform to relevant British Codes of Practice, BS 8303, BS EN 15287-1.

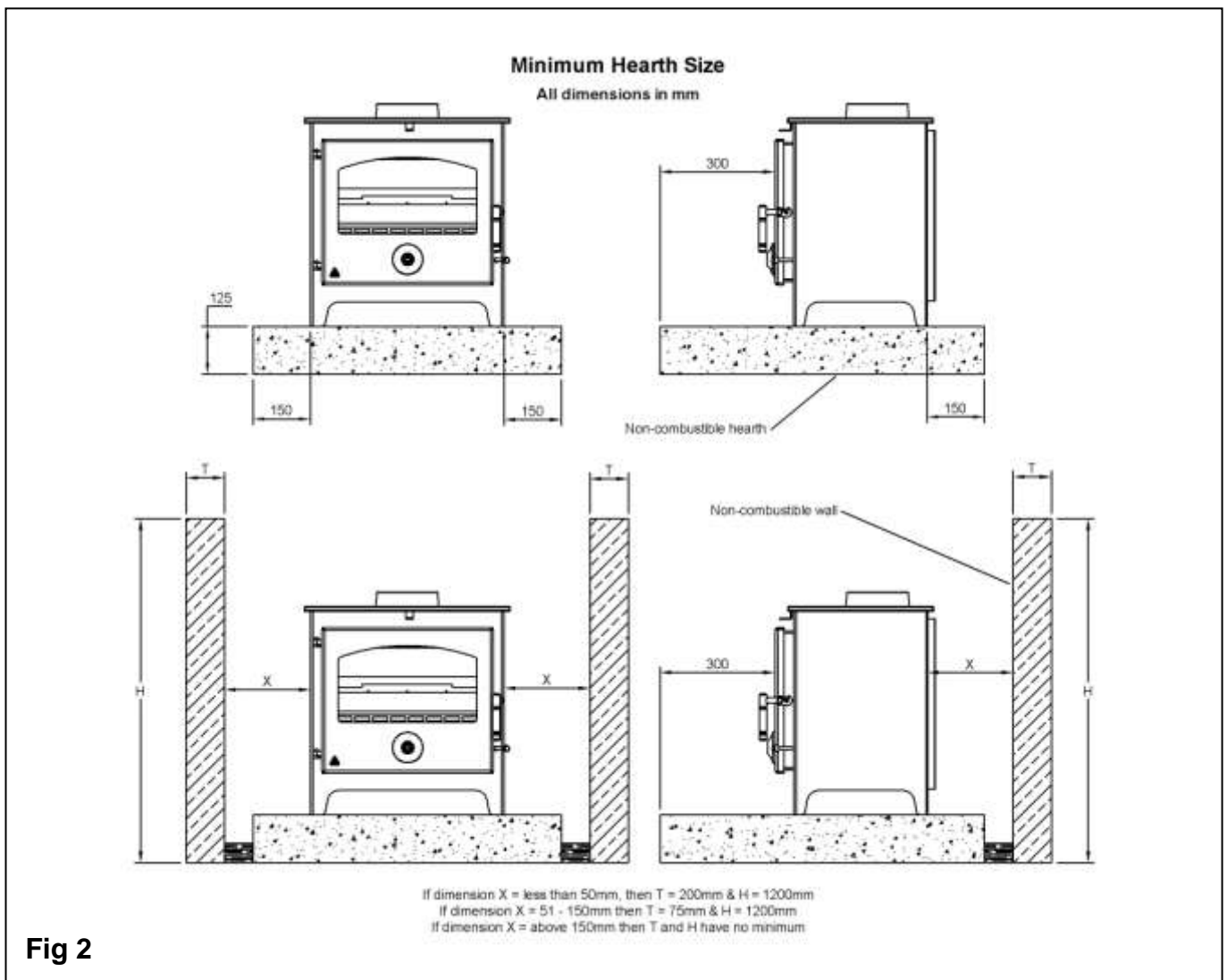

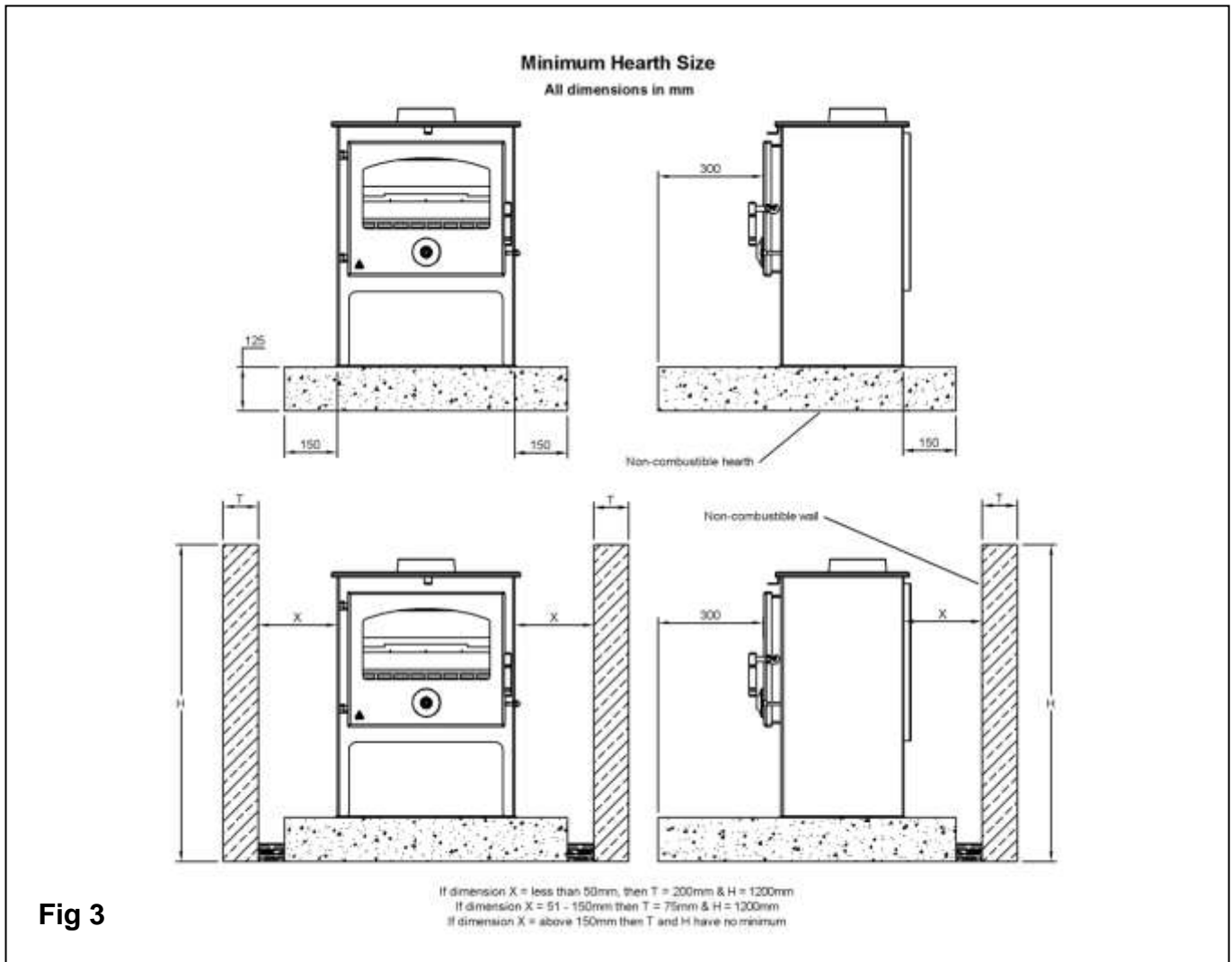

**Fig 3**

**TECHNICAL SPECIFICATION**

	Smokeless Fuel	Wood
Recommended Fuels	Smokeless solid fuel for closed appliances	Seasoned wood with <20% Moisture content
Recommended Refueling Interval	4 hours	1 hour
Nominal Output	7.7 kW	8.3 kW
Efficiency	66.9%	75.1%
Weight (empty)	93 kg	93 kg
Dimensions – Standard (H x W x D)	540 x 540 x 420	540 x 540 x 420
Dimensions – Pedestal (H x W x D)	780 x 540 x 420	780 x 540 x 420
Flue Socket	152.5mm (6")	152.5mm (6")
Flue Gas Temperature (at outlet)	382°C	309°C
Flue Draught Requirement	0.04-0.06 in WG	0.04-0.06 in WG
Flue draught (nominal output)	0.048 in WG	0.048 in WG
Flue gas mass flow	9.0 g/s	6.4 g/s
Hearth (W x D x T)	820 x 865 x 125	820 x 865 x 125
Minimum Distance To Combustibles	Rear 150mm Sides 800mm	Rear 150mm Sides 800mm

All dimensions in mm

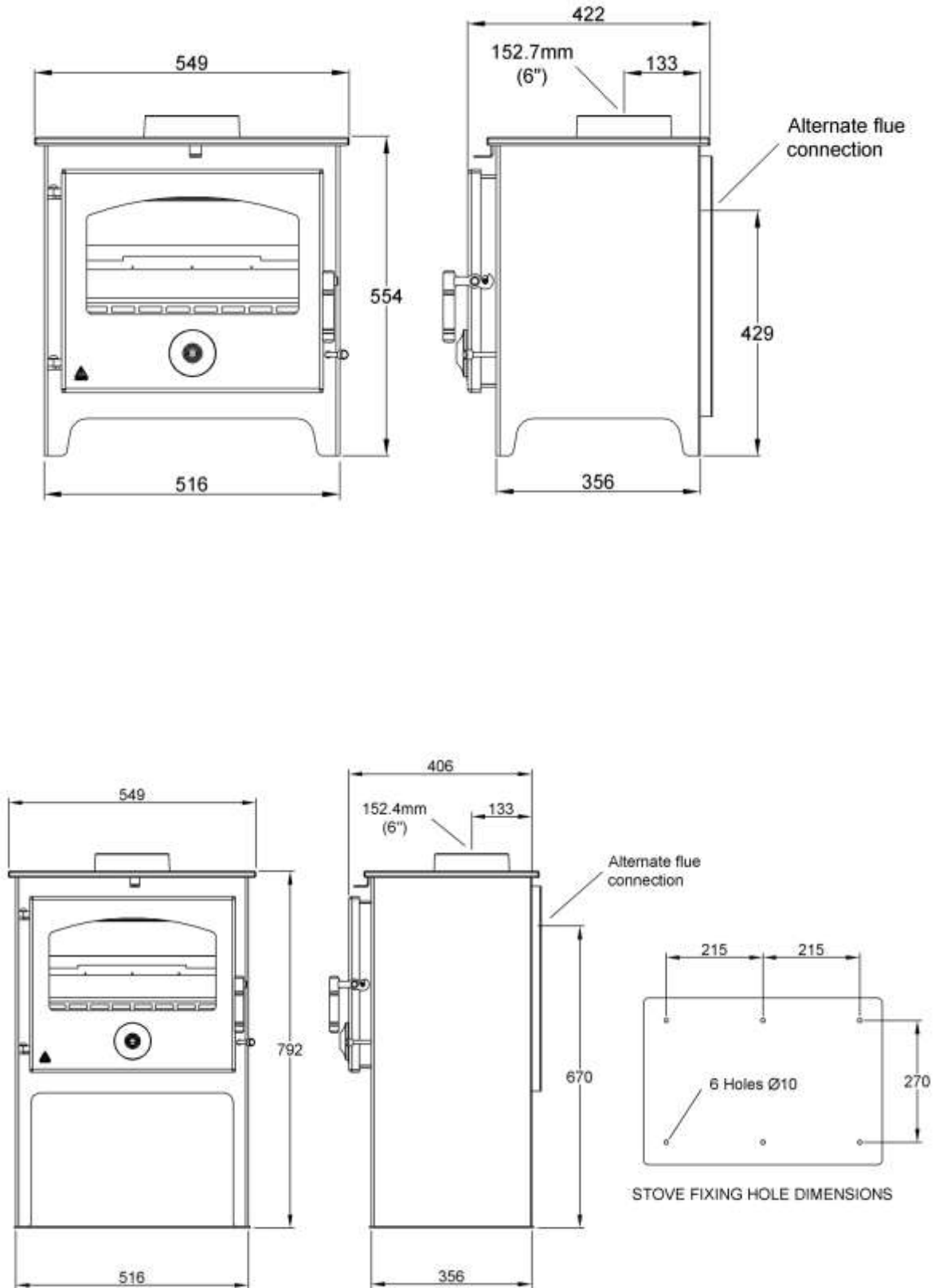

Fig 4

## Chimney

For correct operation of the stove, the height of the chimney from its base should not be less than 4.5m and it should terminate above the roof in accordance with current Building Regulations. All requirements as outlined in BS EN 15287-1:2007 design, installation and commissioning of chimneys should be observed. Failure to observe the recommended minimum sizes or methods of flue connection may lead to fume emission and reduce burning rates.

When fitting the stove to an existing chimney, its internal and external condition should be checked before the appliance is installed. The chimney must be swept before installation. The flue must be stable and free from all jointing compounds.

If the stove is fitted in place of an open fire then the chimney should be swept one month after installation to clear any soot falls which may have occurred due to the difference in combustion between the stove and the open fire.

Where the chimney is believed to have served an open fire installation it is possible that the higher flue gas temperature from the closed appliance may loosen deposits that were previously firmly adhered, with the consequent risk of flue blockage. It is therefore recommended that the chimney be swept a second time within a month of regular use after installation.

Ensure a new chimney is free of internal projections, such as jointing compounds, before installing the appliance. The stove must not share a chimney with another appliance.

When using a factory-made insulated chimney, it must comply with BS 1856-1. The chimney and connecting flue pipe must have a minimum diameter of

150mm and its dimension should not narrow to less than the size of the outlet socket of the stove at any point.

After deciding whether to use the top or rear exit on the stove, fit the flue socket plate and blanking plates in the required positions, ensuring a good seal is made with fire cement or similar. When using the rear exit, always use an appropriate tee; a 90° elbow should not be used.

Advise the end user to have the chimney thoroughly swept at least every twelve months. If bituminous coal or wood is used, the chimney may require more frequent sweeping.

### Flue layout

If the stove is installed in an existing recess directly below a chimney flue, the exhaust end of the flue pipe must extend into the throat of the chimney, at least 150mm into the overhanging brickwork. Any cavities or pockets above the throat plate should be filled.

If the stove is connected via flue pipe to an existing brick chimney, square bends and horizontal runs must not be used. A cleaning door must be included at every bend. See **fig 5** below for details.

Avoid extended horizontal flue runs. Whichever method of installation is used, air must not be allowed to enter the chimney, save through the stove; all joints must be airtight. If the chimney is unlined and there is doubt as to its condition, it should be lined in accordance with current Building Regulations.

Provision must always be made for sweeping the chimney. Cement pipes and fittings must not be used within 2m of the stove outlet. Plain pipe chimneys are not recommended, but propriety makes of insulated chimneys may be suitable; refer to manufacturers' guidance.

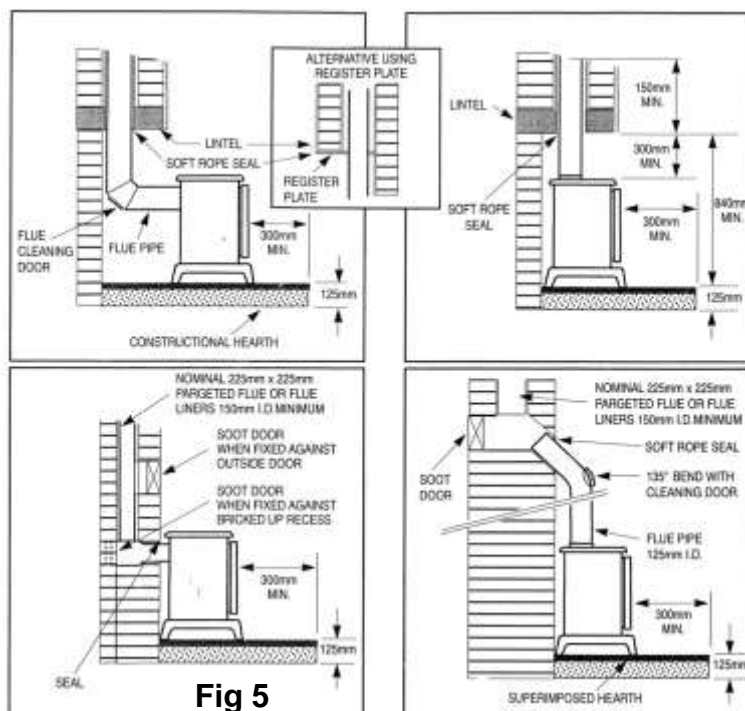

**Fig 5**

## Air supply

A permanent, unobstructed air vent is required. It must communicate directly with the outside or an adjacent room which itself has a permanent air vent. The vent must have a minimum effective area of 550mm<sup>2</sup> per kW of rated output above 5kW. Position the vent in a place not liable to accidental blockage.

## Extractor fans

If an extractor fan is located close by, it could affect the stove's performance. The supply of air should be such that the operation of the stove and chimney are unaffected when the extractor fan is running. A separate air supply may be required.

A flue draught interference test will determine whether the extractor fan is having an effect. Where the fan is in the same room as the appliance, close all windows and doors. Where the fan is in an adjacent room, close all external doors and windows, but leave the internal doors open. Set the extractor fan to full capacity; after the fan has established its normal airflow pattern, perform combustion analyses of the stove at minimum and maximum outputs. Perform similar tests while the fan is switched off.

Interference tests should also be carried out if there are other appliances close by that move air to the outside, such as tumble dryers.

## COMMISSIONING

- Ensure all parts are correctly fitted, and that the stove is set for the correct fuel.
- Check the operation of: the door catch (ensuring it holds the fire door tight); the bottom grate riddling mechanism (using the tool supplied); the air regulator wheel; and the air wash control.
- Test the flue draught. The minimum draught required is 0.04 in WG; the maximum allowed is 0.06 in WG.
- Light the stove and allow to reach a steady burn before checking for fume leakage into the room; open the door and carry out a spillage test.
- Demonstrate the methods of operation to the end user. Explain the need for an annual service and regular maintenance schedule. Record your details in the space provided at the rear of this manual.
- Ensure these instructions are left in the end user's possession.

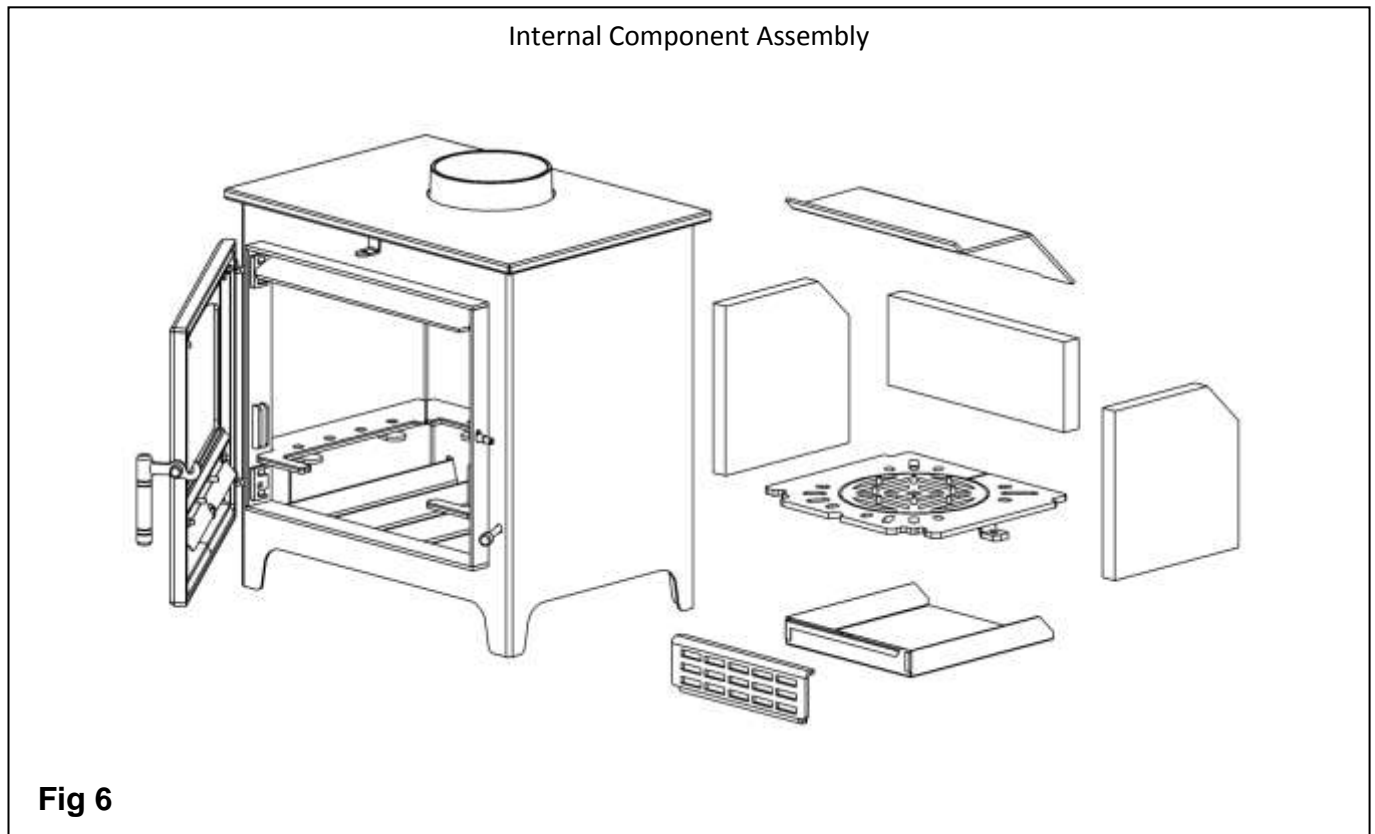

## SERVICING

Every year, the stove should be serviced and the chimney swept. Always use a qualified engineer. The best time is just after the end of the heating season, when the stove is not likely to be in use. Allow the stove to cool before the engineer attends. Procedure:

- Remove the front grate, fire bricks, throat plate, bottom grate and ash pan.
- Sweep the chimney thoroughly from an accessible position (see **fig 5, page 12**).
- Clear out any large deposits from inside the combustion chamber and vacuum that which remains. If necessary, scrape off deposits that have attached to the walls of the chamber.

- Clean the throat plate, bottom grate and front plate with a wire brush. Use a soft brush for the firebricks.
- Replace any damaged items and re-fit in the reverse order.
- Remove the door glass and clean with a damp cloth; wipe with a dry cloth. Inspect and replace the door seal if necessary.

Check operation of the door catch, ensuring a tight seal is made.

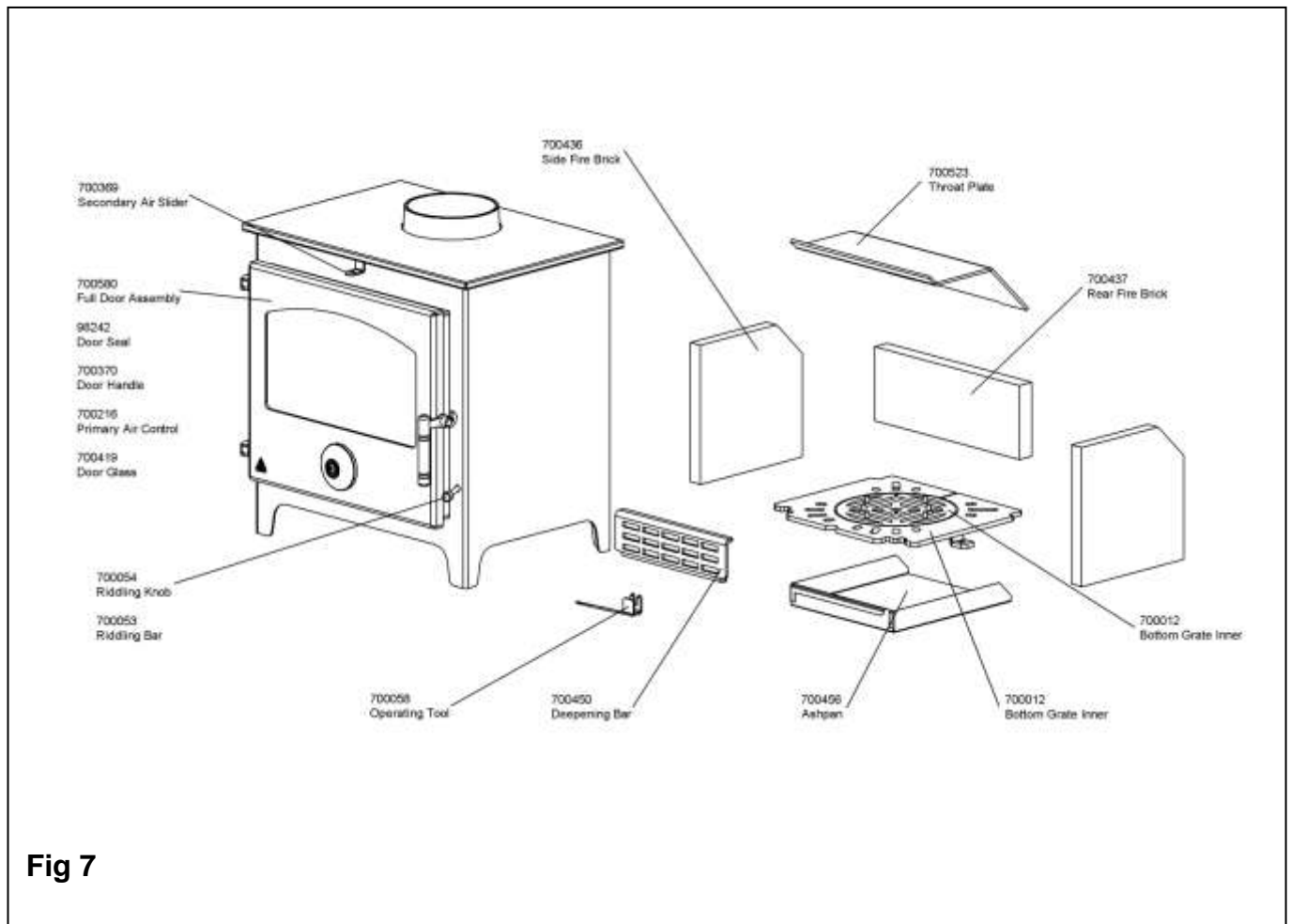

**The following information should be provided upon installation of the appliance for householder reference:**

**Installation Engineer:**

---

**Company:**

---

**Company Address:**

---

---

---

**Company Tel. No:**

---





**TR ENGINEERING LTD**  
**Thorncliffe, Chapeltown,**  
**Sheffield, S35 2PH.**  
**Tel: (0114) 2572300**  
**Fax: (0114) 2571419**  
[www.trianco.co.uk](http://www.trianco.co.uk)

Copyright in this brochure and the drawings and illustrations contained within are vested in TR Engineering Ltd and neither the brochure or any part thereof may be reproduced without prior written consent.

TR Engineering's policy is one of continuous research and development. This may necessitate alterations to this specification. Instructions correct at time of going to print.

August 2012

Item No. 700482 Iss. 3