

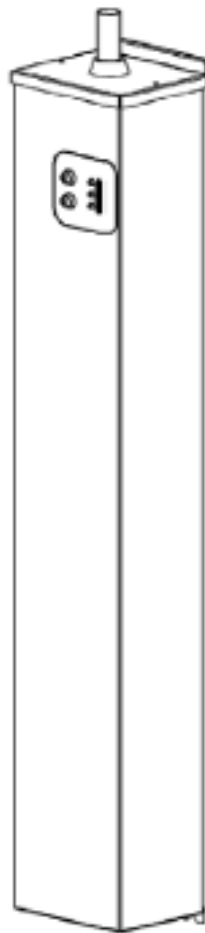

CLASSIC 2, 6, 9, 11 & 12KW BOILER



INSTALLATION, OPERATION AND SERVICING INSTRUCTIONS

**Please read these instructions carefully before installing and operating this
appliance**

CONTENTS

1. Health & Safety	3
2. Pre-Installation Notes	3
2.1 Ventilation and Siting	3
2.2 Power Supply and Wiring	3
2.3 System	3
3. After Sales Service Information	3-4
3.1 How to Report a Fault	3
3.2 Technical Assistance	4
4. Introduction	4
5. Users Instructions	5
6. Simple Fault Finding	6
7. Technical Specification	6-9
8. Installation Instructions	6
8.1 Regulations	6
8.2 Health & Safety at Work Act	6
8.3 Siting the Boiler	6
8.4 Unpacking the Boiler	6
8.5 Fixing to the Wall	6
8.6 Ventilation Requirements	7
8.7 Water Systems	7-9
9. Multiple Boiler Installations	9-10
10. Wiring Instructions	11
11. Servicing Instructions	17
11.1 Parts Replacement	17
11.2 Casing Removal	17
11.3 PCB Assembly Replacement	17
11.4 High Limit Thermostat Replacement	17
11.5 Thermistor Replacement	17
11.6 Element Replacement	18
12. Fault Finding	18
13. Spares List	23-24

Important:

General Information:

To keep your boiler running efficiently DO NOT OBSTRUCT OR COVER any ventilation air inlet on the appliance or the compartment where it is installed.

To keep the casing clean, switch 'OFF' the boiler at the electrical supply and simply wipe with a damp cloth. DO NOT use abrasive cleaning fluids as this may damage the stove enamel paintwork.

Important

The electrical supply requirements:-

The 2kW boilers and 6kW boilers meet the requirements of EN 61000-3.3.

The 9kW and 11kW boilers must be installed in premises having a service of $\geq 100A$ per phase.

The 12kW boiler must be installed in premises having a system impedance of not more than $0.1939 + 0.1939\Omega$.

1. Health & Safety

Information for the Installer and Service Engineers

Under the Consumer Protection Act 1987 and the Health & Safety at Work Act 1974, it is a requirement to provide information on substances hazardous to health (COSHH Regulations 1988).

The company takes every reasonable care to ensure that these products are designed and constructed to meet these general safety requirements, when properly used and installed.

To fulfil this requirement products are comprehensively tested and examined before despatch.

When working on the appliance it is the Users/Engineers responsibility to ensure that any necessary personal protective clothing or equipment is worn appropriate to parts that could be considered as being hazardous to health and safety.

This appliance may contain some of the items below:

INSULATION AND SEALS

Mineral fibre, insulation.
May be harmful if inhaled. May be irritating to the skin, eyes, nose or throat. When handling avoid inhalation and contact with eyes. Use (disposable) gloves, face masks and eye protection.

After handling wash hands and other exposed parts. When disposing, reduce dust with water spray, ensure parts are securely wrapped.

GLUES, SEALANTS & PAINT

Glues, sealants and paints are used in the product and present no known hazards when used in the manner for which they are intended.

Notes:	
a)	Electrical safety checks should be carried out by a competent person.
b)	It is a requirement of the guarantee and any extended warranty that an annual service is carried out by a competent person.
Installation Engineers Signature	_____
Company Name (if applicable)	_____
Company Address	_____

Company Tel. No.	_____

2. Pre-Installation Notes

Before installation, it is imperative that the following guidelines are heeded to ensure the trouble-free and efficient operation of the boiler.

2.1 Ventilation and Siting

When siting the boiler in a confined space it is essential that adequate ventilation be provided. This will ensure that air is allowed to circulate freely around the appliance keeping down the ambient

temperatures. Refer to Ventilation Requirements (Page 7) for further details.

Ensure that the area surrounding the boiler is kept free of items which would impede the good ventilation of the appliance (e.g. towels, linen, etc.).

When siting the boiler, take into account the potential requirement for future servicing. Enough space should be provided at the front of the boiler to enable an engineer to adequately service and/or replace items such as the PCB or heat exchanger. Space should also be available for the removal of the front casing panel. Please refer to siting information (Page 6) for clearance dimensions.

2.2 Power Supply and Wiring

The power supply to the boiler must meet the minimum requirements of the unit being installed, with special attention paid to the supply current, cable size and RCD recommendation. The supply voltage to the appliance must never drop below **207 volts**.

When fitting external controls, such as a room thermostat or programmer, particular consideration should be given to the wiring of these secondary items into the appliance. Please refer to the wiring instructions (Pages 11) for full details. Any breakdown attended to by T R Engineering Ltd which is found to be caused by an incorrectly wired appliance will be chargeable.

It is important that the pump is wired back to the boiler as shown in the wiring diagram.

2.3 System

Isolation valves must be fitted on both the flow and return pipe work of each boiler to be installed. These are useful as from time to time the boiler may require draining of water and the lengthy drawing-off process can be avoided by the astute placement of these valves. Please refer to Page 8 for further details.

Ensure that any isolation valves are open before first use and that the system is full of water.

The boiler can be fitted only in an upright position, with the flow connection to the top of the boiler.

3. After Sales Service Information

A qualified field service engineer is available to attend a breakdown occurring during the boiler's guarantee period.

The boiler must be made for attendance during normal working hours, Monday to Friday.

3.1 How to Report a Fault

Step 1

Contact your installation or service engineer, who should assess the unit and works carried out on the appliance prior to requesting the attendance of an engineer from T R Engineering Ltd.

Step 2

Please note that upon attendance by a T R Engineering Ltd engineer, a charge will be made where:

- The engineer finds no fault with the boiler.
- The cause of the breakdown is due to parts of the system not manufactured or supplied T R Engineering Ltd.

Aztec Classic Electric Boilers

- The boiler has not been installed in accordance with these instructions.
- The boiler has not been commissioned by a qualified engineer.
- The boiler has not been serviced annually since installation.
- The breakdown occurs outside the guarantee period.
- The appliance has not been maintained correctly.
- The breakdown occurs due to use of the boiler not sanctioned by these instructions.
- The breakdown occurs as a result of work on the appliance by an unauthorised third-party.

Important:

Invoices for attendance and repair work by any third-party will not be accepted unless authorised in advance by T R Engineering Ltd.

3.2 Technical Assistance

A team of trained technical advisors are available to discuss any problem with the appliance. In many cases, the problem may be solved over the telephone, eliminating the need for an engineer's visit.

Before making contact, please have the following information ready:

- The appliance serial number or your unique customer identification number (issued upon registration of the appliance with T R Engineering Ltd).
- A description of the fault and any unusual behaviour by the boiler before the failure occurred.
- The installation and commissioning dates and the details of any annual services.

Appliance Serial No: _____ Cust. ID No: _____ Installation Date: __/__/__

Service Centre and Technical Support

Tel: 0114 257 2300 Fax: 0114 257 1419

Hours of Business

Monday-Thursday 8:30am – 17:30pm

Friday: 8:30am – 14:30pm

4. Introduction

The Aztec electric boiler is a wall mounted electric central heating boiler designed with smaller properties in mind. Fitted vertically only and requiring access to the front and the right hand side of the boiler FOR SERVICING. Once the boiler is switched on it is fully controlled by an automatic management system which monitors the safety and running functions of the boiler. Designed to work on a fully pumped wet system only. The boiler produces hot water by passing water over electric heating elements housed in an insulated stainless steel heat exchanger.

There are five boilers in the range with outputs ranging from 2kW (6825 Btu/hr) to 12 kW (41,000 Btu/hr).

IMPORTANT SAFETY NOTES

Read these instructions before installing your boiler.

The heating system must comply with the latest editions of British Standards 5449 and The Building Regulations and Electrical Wiring Regulations BS 7671.

1. Always switch OFF the electrical supply before removing the cover.
2. If any part of the boiler is modified, then the guarantee/warranty will be invalidated.

We recommend that you keep these instructions in a place near your appliance for easy reference.

The Trianco Aztec wall mounted boiler has been designed to conform to European Directive/Standards.

EN 60335-1:1994/A16:2001, EN 60335-2-35:1998/A1:2000, EN 55014-1:2000, EN 55014-2:1997, EN 61000-3-2:2000 and EN 61000-3-3:1995.

THE PERSON(S) WHO INSTALLS THIS APPLIANCE SERVICES OR CARRIES OUT ANY REMEDIAL WORK, I>E> ELECTRICAL FAULT FINDING, MUST HAVE SUITABLE ENGINEERING QUALIFICATIONS.

WARNING: DO NOT SWITCH ON THIS APPLIANCE IF THERE IS ANY POSSIBILITY THAT THE WATER HEAT EXCHANGER IS FROZEN.
--

THE INSTALLATION OF THIS APPLIANCE MUST MEET THE REQUIREMENTS OF THE CURRENT ISSUES FOR ELECTRICAL INSTALLATIONS IEE WIRING REGULATIONS.

5. User Instructions

The Trianco Aztec boiler has been designed and constructed to give years of trouble free service and these instructions are provided to assist you in obtaining the best performance with the least trouble and cost.

The boiler is fully automatic in operation and requires little attention other than the setting of the thermostat and any external system controls such as a room thermostat and time switch.

IMPORTANT:

DO NOT COVER OR BOX IN YOUR BOILER, ALLOW AIR TO CIRCULATE FREELY AROUND THE APPLIANCE.

WARNING: DO NOT ATTEMPT TO SWITCH ON THE BOILER IF THERE IS ANY POSSIBILITY THAT THE WATER HEAT EXCHANGER IS FROZEN.

Before firing the boiler, ensure the system is full of water and any valves fitted to the system are open.

- Check that the time switch/programmer (if fitted) is ON and the room thermostat is calling for heat.
- Switch on the electrical supply to the boiler and after a few seconds the boiler's green and amber light should illuminate.
- Set the boiler thermostat to the required temperature using the control buttons.

Aztec Classic Electric Boilers

- Set the time switch/programmer (if fitted) to the times and programs required.
- The boiler will now operate automatically, cutting in and out according to the heat demand.

To Turn Off the Boiler

- Switch off the boiler at the time switch/programmer (if fitted).
- If the boiler is to be switched off for any length of time it is recommended that the mains supply to the boiler is switched OFF.

Boiler Control Thermostat

The boiler control thermostat enables you to select the temperature of the water leaving the boiler. It is calibrated between 35°C and 75°C.

Using a small screwdriver set the temperature by turning the knob to the required setting or when the case is fitted use the buttons to switch between low and high (35°C and 75°C in 5 degree increments).

Boiler Indicator Lights

There are twelve LED indicator lights on the boiler fascia panel these are:

- LED 1 – **GREEN** – Power to the boiler
- LED 2 – **AMBER** – Illuminated – In run mode
Flashing – Temperature satisfied
- LED 3 – **RED** – Boiler fault
- LED 4-12 – **RED** – Temperature lights 35°C – 75°C

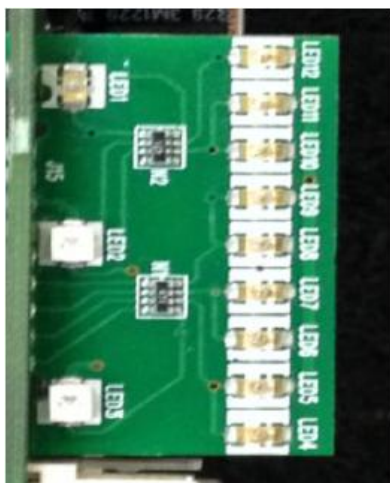

If the red LED light flashes, this means a fault has occurred. This

would result in the boiler continuing to operate at a reduced output. If the red LED is permanently on, this indicates a fault has occurred (see simple fault finding chart on **Page 5**).

Room Thermostat

The room thermostat should not be positioned near a source of heat such as a radiator or exposed to the sun as this will cause the central heating to switch off before the room is up to temperature. Follow the manufacturer's instructions for best siting position for the thermostat.

Frost Protection

If the boiler and central heating is shut down for many hours during cold weather, the water may be in danger of freezing. The boiler incorporates a frost thermostat.

If the system is shut down for a long period during very cold weather, it is advisable to completely drain the system. However, frequent draining should be avoided, especially in hard water areas, as this could lead to scaling of the boiler waterways.

WARNING: DO NOT SWITCH ON THIS APPLIANCE IF THERE IS ANY POSSIBILITY THAT THE WATER HEAT EXCHANGER IS FROZEN.

Boiler Pump Overrun

The pump will overrun for a short period of time after the boiler turns off.

Time Switch/Programmer

When choosing the operating times for your boiler, it is useful to remember that central heating usually takes between half an hour to an hour before it becomes effective. It is suggested that the time switch/programmer is set to bring on the heating about an hour after boiler shutdown. The timer can therefore be switched off earlier as an economy measure.

Cleaning Casings

Use hot soapy water applied with a damp dry cloth for the enamel, then dry with a soft dry cloth.

Simple Maintenance

Ensure that the natural ventilation around the boiler is not obstructed. If fitted in a compartment ensure all ventilation grilles are clear.

6. Simple Fault Finding

If the boiler fails to start for no apparent reason make the following checks before calling your service engineer.

1. Is the green LED illuminated?
NO
2. If the red LED is permanently illuminated contact your service engineer.
3. Flashing red LED indicates an open circuit. The boiler can still be operated. Service engineer should be contacted.
4. Check to see if all external controls i.e. programmer or room thermostat is calling for heat.

Resetting the Boiler

If a fault has occurred and the red LED is illuminated but the pump continues to run, then switching the power off for 30 seconds and then on again should reset the light. This may be caused by the ambient temperature around the boiler being too high. Check to ensure that any boiler ventilation is not obstructed. If the fault reoccurs contact your engineer.

IMPORTANT: Electrical safety checks should be carried out by a qualified electrical engineer.

7. Technical Specification

MODEL	Aztec 2kW	Aztec 6kW	Aztec 9kW	Aztec 11kW	Aztec 12kW
Electrical Input	2kW	6kW	9kW	11kW	12kW
Supply Current (amp)	8.5A	25A	39A	45A	51A
RCD Rating (amp)	13A	32A	40A	50A	63A
Minimum Cable Size (mm)	1	4	6	10	16
Weight (kg)	7.0	8.1	10.6	10.8	10.8
Water Content (litres)	1.0	2.1	3.2	3.2	3.2
Width (mm)	164	164	164	164	164
Depth (mm)	130	130	130	130	130
Height (mm)	550	823	1073	1073	1073
Mains Supply	230V 50Hz				
Max Operating Pressure	3 bar 43.5 psi				
Test Pressure	6 bar 87 psi				
Boiler Flow Temperature	Adjustable between 35°C and 75°C, located on the front casing				
Limit Thermostat	Factory set at 100°C				
Casing Finish	Stove enamelled white				

8. Installation Instructions

8.1 Regulations

Installation of the boiler must comply with the following British Standards and Regulations:

BS 5449 – Forced Circulation Hot Water Central Heating Systems.

BS 7074 – Part 1 – Code of Practice for Sealed Water Systems.

The Building Regulations

Current I.E.E Regulations

Local water undertaking By-Laws

8.2 Health & Safety at Work Act

The installer should be aware of his responsibilities under the Act and provide where necessary, appropriate protection for persons carrying out the installation. In the interests of safety a competent engineer should install the boiler and all wiring must be carried out in accordance with current IEE wiring regulations.

IMPORTANT:

ALL ELECTRICAL WORK MUST BE CARRIED OUT BY A QUALIFIED ELECTRICAL ENGINEER TO CURRENT IEE WIRING REGULATIONS.

8.3 Siting the Boiler

IMPORTANT: NOT TO BE INSTALLED IN A SHOWER COMPARTMENT OR BATHROOM.

The boiler is designed to be fitted in an **upright position only**. Ensure adequate clearance is allowed for making water connections as the boiler can be fully serviced from the front. The boiler must also be fitted in a dry well ventilated position, which is not subject to adverse temperature conditions (see Ventilation requirements).

Care should be taken when siting the appliance to make sure adequate access is available for future servicing of the appliance. Please note the PCB and heat exchanger assembly may require removal during such times.

When installed in a compartment with a hot water cylinder (see Fig. 1), we recommend that the boiler is fitted in position 1; if fitted in position 2, provision should be made at the front of the boiler to

enable the removal of the front casing. In both cases, where any additional equipment like a hot water cylinder or system controls are to be fitted after the boiler has been installed, attention should be given to ensure that they do not restrict access to the boiler for servicing.

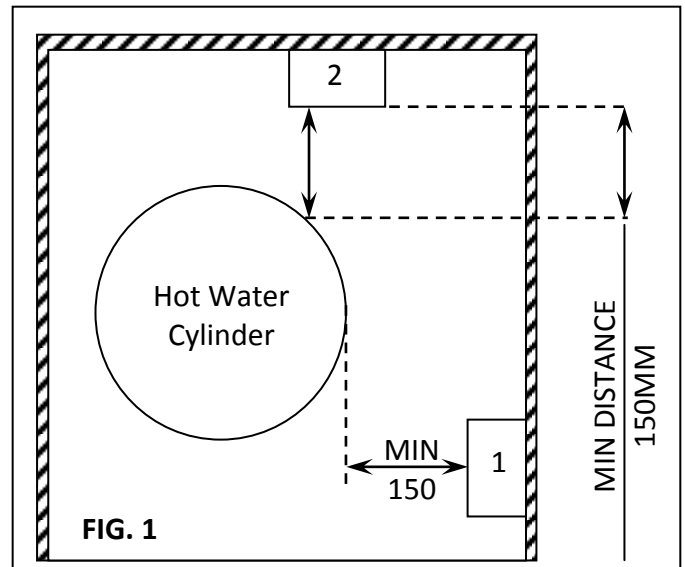

8.4 Unpacking the Boiler

Carefully open the boiler carton, remove boiler and place in a safe place until required.

NOTE – ALWAYS STORE THE BOILER IN A DRY PLACE PRIOR TO FITTING. DO NOT ALLOW THE BOILER TO BE STORED WITH THE CASING REMOVED.

8.5 Fixing Boiler to the Wall

Important:

DO NOT CUT FLOW AND RETURN PIPES

1. The boiler should be fitted to a suitable wall in an upright position. Flow tapping must be at the top of the boiler.
2. Using fixing dimensions supplied work out position of boiler, mark four mounting holes and drill 6mm diameter to a depth of 38mm.
3. Fit plastic wall plugs into holes and fit bottom two mounting screws.
4. Hang on bottom two screws and push the boiler back towards the wall and secure in position with top two fixing screws. The flow tapping must be at top of the boiler (continued on Page 7).

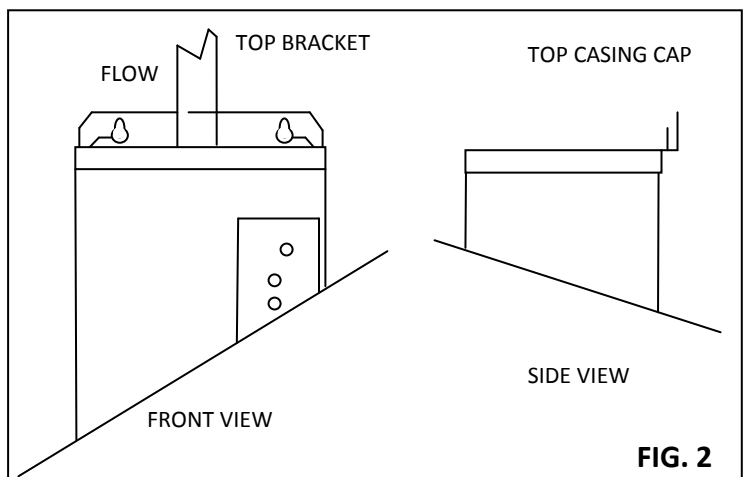

Aztec Classic Electric Boilers

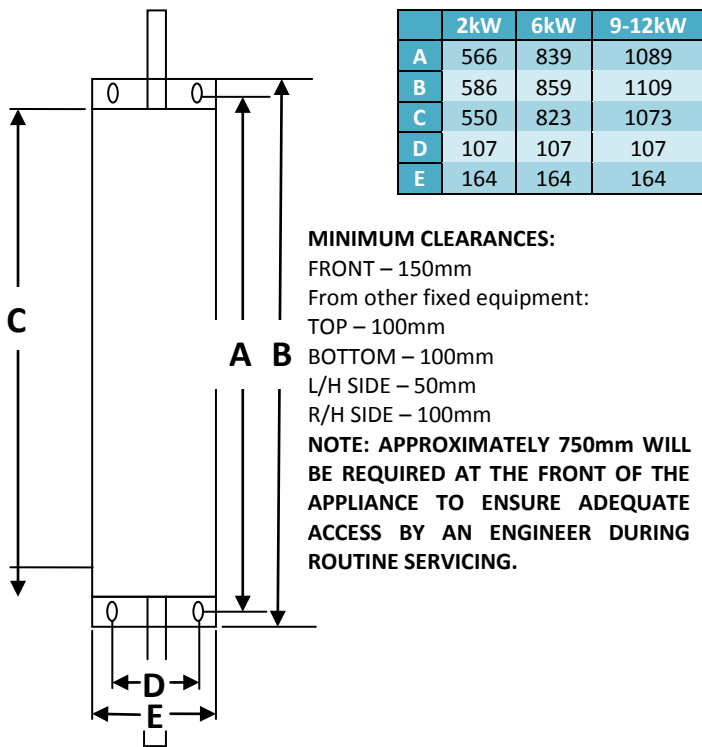

FIG 3

5. Removing four casing screws and washers will allow casing to be removed.
6. Slide top casing cap upwards this will allow front casing to slide forward.
7. With the front casing removed fit three strain relief bushes into base of back panel.
8. Fit pipe sealing grommet into top casing panel and cut off end to allow pipe to slide through (See Fig. 4).

IMPORTANT: TOP CASING PANEL WITH GROMMET MUST BE RE-FITTED BACK IN POSITION BEFORE MAKING TOP PIPE CONNECTION. ALTERATION OR FAILURE TO COMPLY WILL INVALIDATE THE WARRANTY.

9. When re-fitting casings slide front casing back into position ensure small temperature adjuster on PCB passes through the hole on the control panel. Slide the top-casing panel down into position and secure panels into position using the four screws.

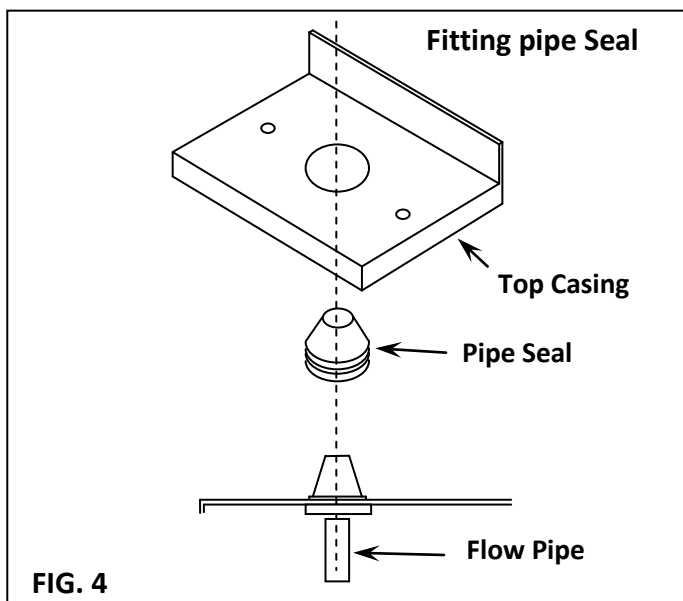

FIG. 4

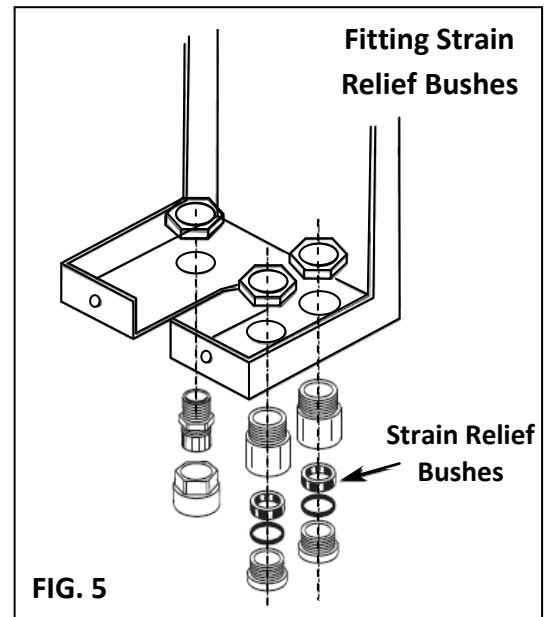

FIG. 5

8.6 Ventilation Requirements

If the appliance is to be fitted in a confined space or compartment with a potential ambient temperature of 60°C or above, it is strongly recommended that adequate ventilation is provided to prevent the overheating of the boiler controls. Aeration of 100cm² will be required to the compartment, in both high and low level positions.

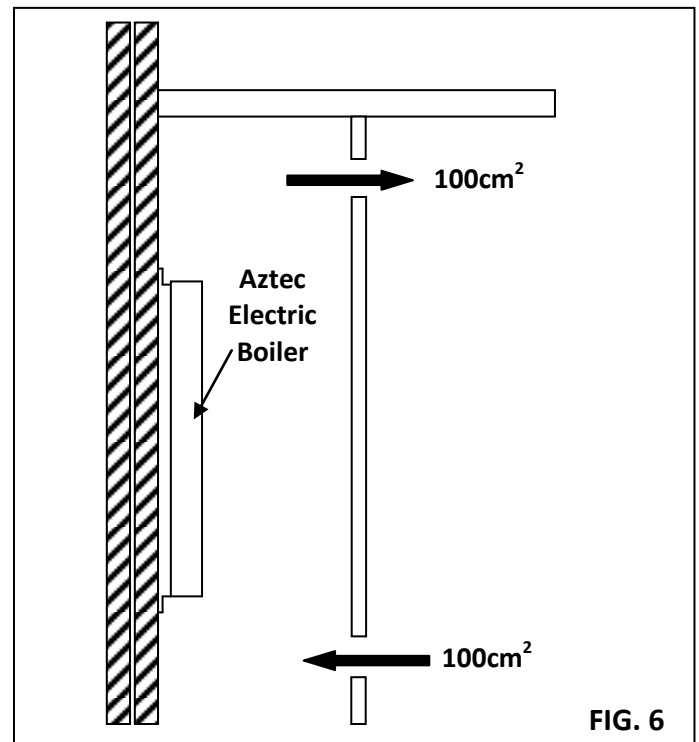

FIG. 6

8.7 Water Systems

IMPORTANT: USE ONLY COMPRESSION FITTINGS WHEN CONNECTING THE BOILER TO THE CENTRAL HEATING SYSTEM.

The installation must comply with the requirements of the following codes of practice.

BS 5449 Part 1 Forced Circulation Hot Water Systems.

BS 7074 Part 1 Code of Practice for Sealed Water Systems.

BS 7593 Treatment of Water in Domestic Hot Water Central Heating Systems.

Aztec Classic Electric Boilers

The water system must be thoroughly flushed out with cold water without the pump in position. Refit the pump and fill the system. Vent all air from the system. Clear any air locks and examine the system for water leaks.

IMPORTANT: ENSURE ALL SERVICE VALVES ARE IN OPEN POSITION. Ensure boiler is fitted with flow pipe at the top and return pipe at the bottom.

The boiler is supplied with 22mm tail pipes top and bottom for connection to the system.

The boiler must be installed using 22mm compression fittings both top and bottom.

The AZTEC ranges of boilers are low water content boilers so require a good flow rate at all times (see below chart).

Model	Min Flow Rate/Min
Aztec 2kW	4 Litres
Aztec 6kW	8 Litres
Aztec 9kW	10 Litres
Aztec 11kW	11 Litres
Aztec 12kW	12 Litres

Aztec boilers are approved for use on fully pumped open vented systems and sealed systems. When fitting on a sealed system a 3 bar safety valve **must be fitted** to the system, where thermostatic radiator valves are fitted it will be necessary to fit a bypass to obtain minimum flow rates.

IMPORTANT: IF MIN FLOW RATES ARE NOT OBTAINED THE BOILER MAY GO TO LOCK OUT ON HIGH LIMIT THERMOSTAT.

Where more than 1 boiler is fitted refer to multiple boiler installations.

System must be flushed out before adding inhibitor to BS 7593:1992 Treatment of Water in Central Heating Boiler.

IMPORTANT: THIS BOILER IS TO BE FITTED ON FULLY PUMPED SYSTEMS ONLY.

Sealed Water System Requirements

The installation must comply with the appropriate requirements of the current issue of BS 4814, BS 5449, BS 6798 and BS 7074 Part 1 and 2.

THE INSTALLATION ENGINEER MUST BE REGISTERED AS A COMPETENT UDHWS INSTALLER.

Safety Valve

A safety valve set at 3 bar must be fitted with the drain routed to the outside of the building. The drain must not discharge above an entrance or a window or any public access area, be clear of any electrical fittings and positioned so that any discharge can be seen.

Expansions Vessel Capacity

A diaphragm type expansion vessel, conforming to the current issue of BS 4814. The expansion vessel must be connected to the systems at a point close to the inlet side of the circulating pump. The expansion vessel volume depends on the total water system volume and the initial system design pressure. For any system an accurate calculation of vessel size is given in the current issue of BS 5449 and BS 7074 Part 1.

The water content of the boiler is given in the Technical Specification. **Note:** A higher initial design pressure requires a larger volume expansion vessel.

The charge pressure must not be less than the static head of the system that is the highest point of the system above the expansion vessel.

Capacity of Expansion Vessel

Where design information is not complete the following chart (Page 9) can be used for selecting the size of the vessel, it should be noted that the size given in the table account of fault conditions.

System Temperature

The normal running temperature of the system is 75°C, if a fault was to occur then the safety device would allow the system temperature to rise to 100°C. It is recommended that this figure be used in the calculations of vessel size.

Connection of the Expansion Vessel

The expansion vessel should be connected in the neutral part of the system this being the return pipe work close to the boiler, refer to sealed system pipe work layout drawing (Fig 11).

Pressure Gauge

A pressure gauge must be permanently fitted in the system covering a range from 0 to 4 bar. Position where it can be seen when filling the system.

Inhibitor

If using an existing system, take care to drain down the entire system including the radiators then thoroughly clean out before fitting the boiler. Attention is drawn to the current issue of BS 5449 and BS 7593 on the use of inhibitors in central heating systems.

Drain Tapping

A drain tapping must be provided at the lowest point of the system, which will allow the entire system to be drained.

Note: Failure to ensure the correct vessel size could result in premature failure of the expansion vessel which in turn may adversely affect other components in the system i.e. circulating pump and diverter valve.

System Make-Up

Water loss from the system should be replaced from a make-up vessel connected to the system. This vessel should be higher than the top of the system. Alternatively provision can be made by pre-pressurisation of the system via a temporary hose connection and through a double check valve (non-return) and stop valve. There must be no permanent connection to the mains water supply even through a non-return valve.

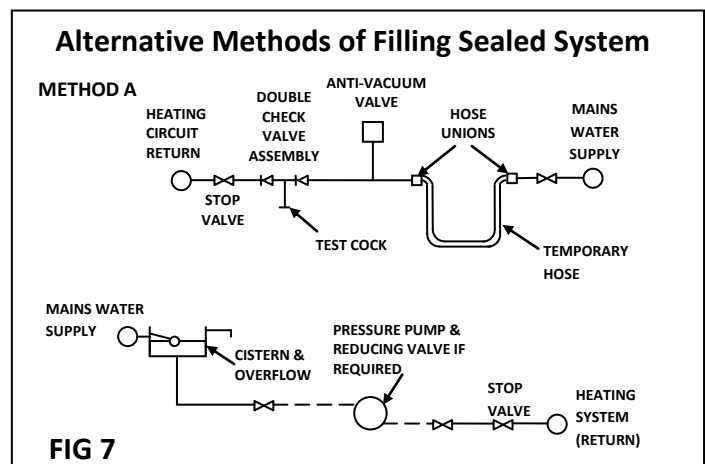

Aztec Classic Electric Boilers

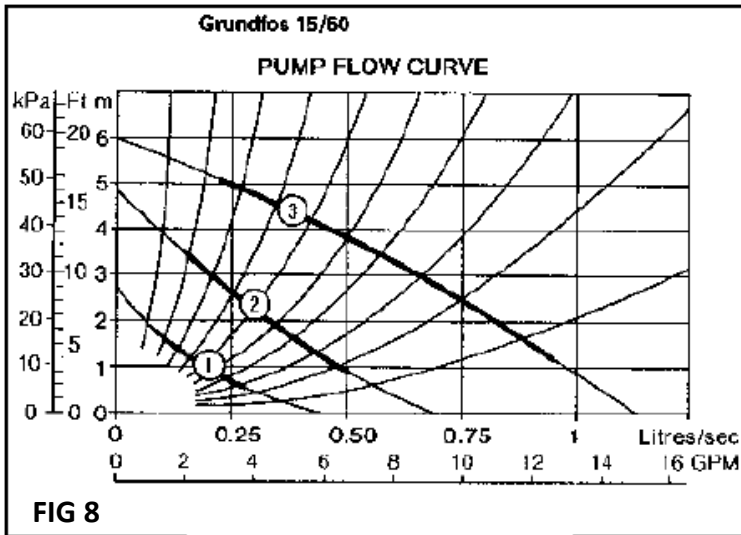

Safety valve setting (bar gauge)	3 bar		
Vessel charge and initial system pressure (bar gauge)	0.5	1.0	1.5
Total water content of system	Vessel volume		
Litre	Litre	Litre	Litre
25	2.3	3.3	5.9
50	4.4	6.7	11.8
75	7.0	10.0	17.7
100	9.4	13.4	23.7
125	11.7	16.7	29.6
150	14.1	20.1	35.5
175	16.4	23.4	41.4
200	18.8	26.8	47.4

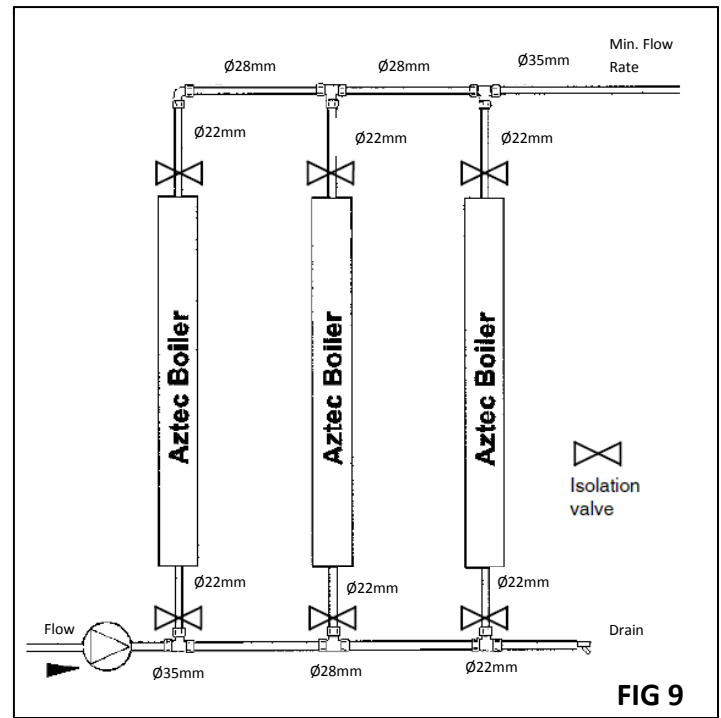

9. Multiple Boiler Installations

Important

Where a greater output is required, more than one boiler can be used in the same system. However, if installing a circulating pump with a higher power demand, the PCB circuit protection fuse may not be adequate. The pump could be wired using a relay. See wiring instructions (**Page 12, Fig 13-15**) for further details.

The boilers must be fitted side by side using common flow and returns. For each additional boiler fitted, it is recommended that the pipe work is increased in size and the pump set to deliver the combined flow rates. The circulating pump will be connected to one of the boilers or via the relay.

We strongly recommend the positioning of isolation valves on the flow and return pipe work of each boiler, as there may be a need to isolate one or more during servicing (**see Fig.9**).

Please contact the Technical Support team for further information.

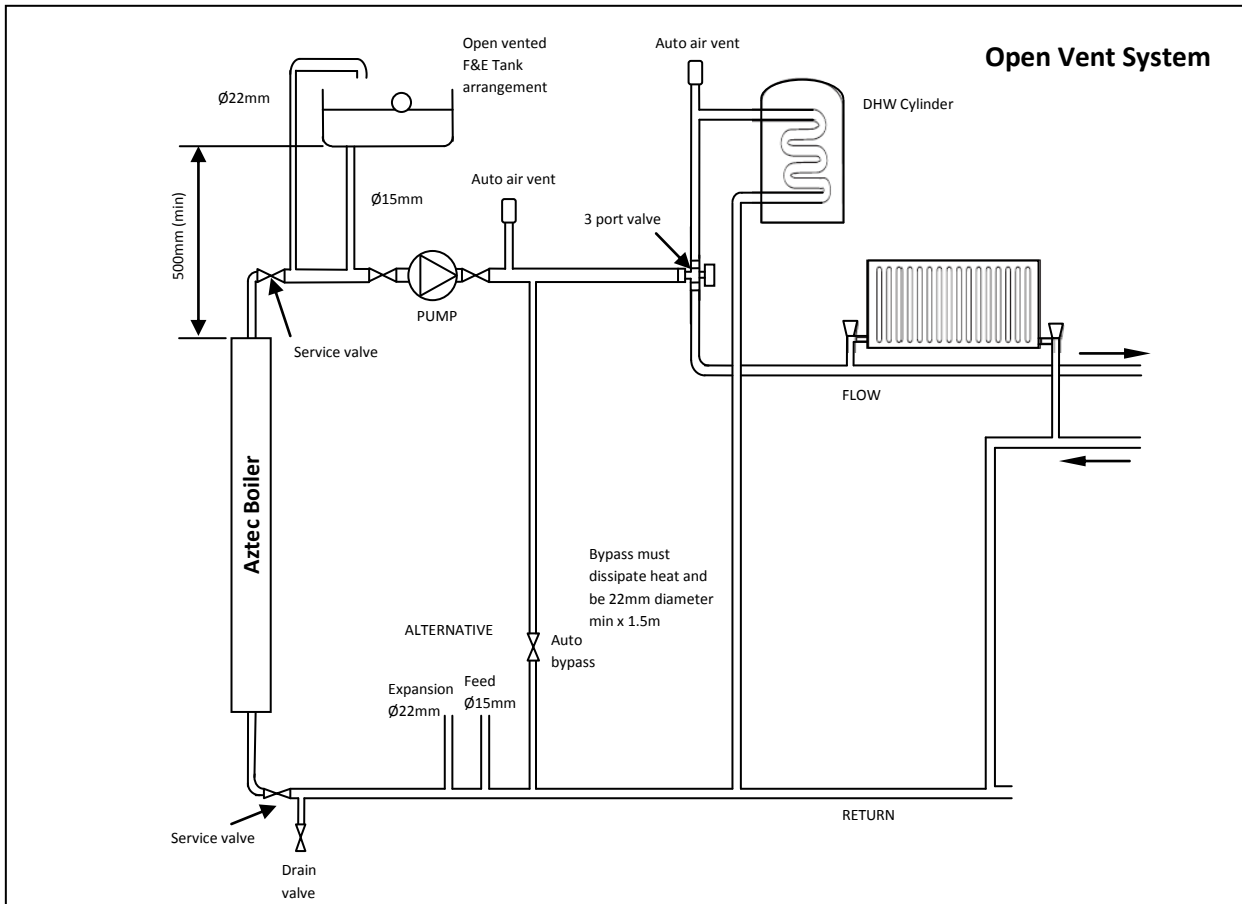

FIG 10

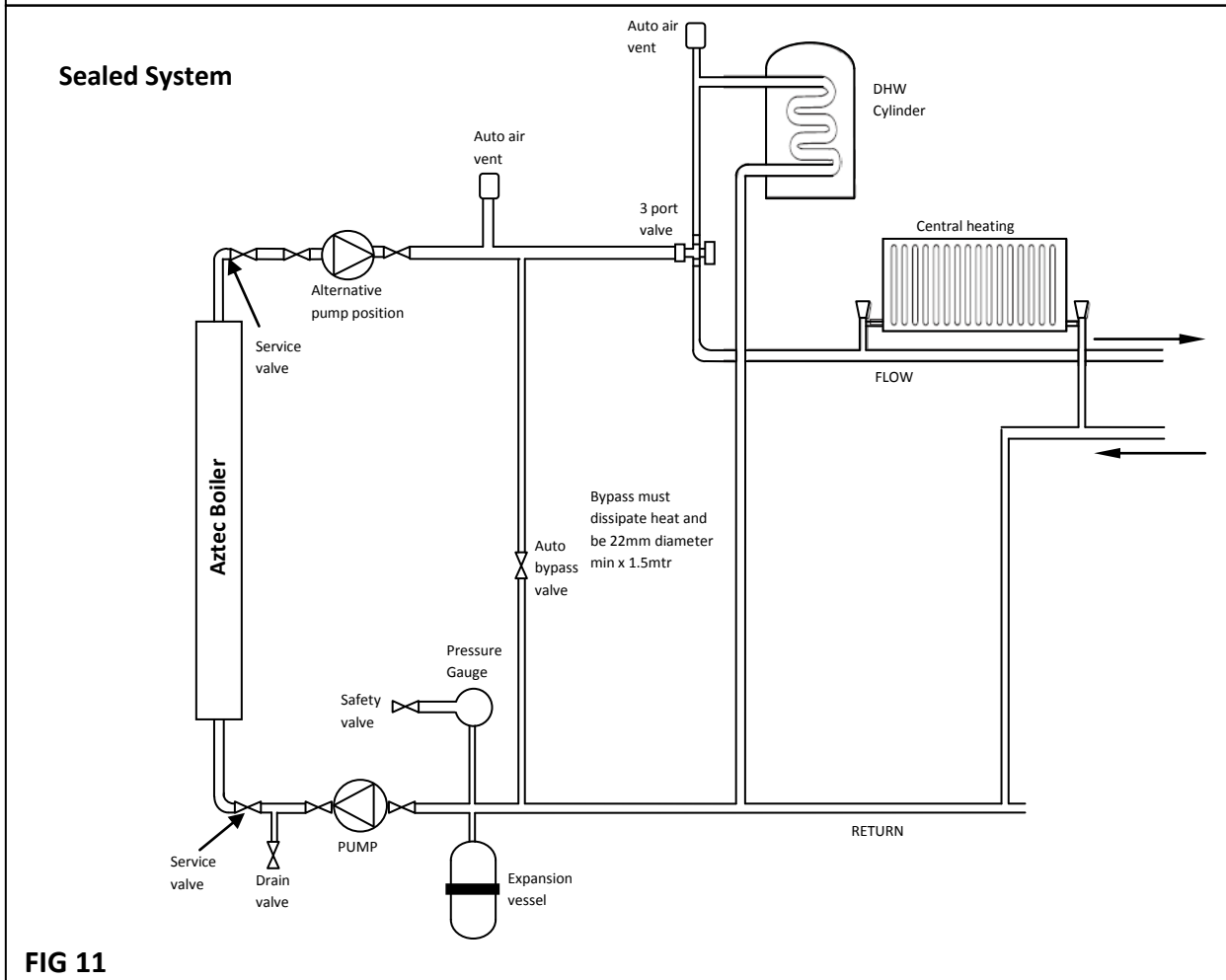

FIG 11

10. Wiring Instructions

ALL ELECTRICAL WORK MUST BE CARRIED OUT IN ACCORDANCE WITH CURRENT IEE WIRING REGULATIONS.

BEFORE COMMENCING INSTALLATION CHECK POWER SUPPLY TO THE PROPERTY TO ENSURE THAT THERE IS SUFFICIENT CURRENT AND VOLTAGE AVAILABLE FOR SIZE OF BOILER BEING FITTED. TAKE INTO ACCOUNT REQUIREMENTS OF OTHER ELECTRICAL APPLIANCES. THE BOILER MUST BE CONNECTED TO THE MAINS SUPPLY BY MEANS OF A DOUBLE POLE LINKED SWITCH WITH 3mm CONTACT GAP IN BOTH POLES.

IMPORTANT: After completing electrical installation work preliminary safety checks should be carried out as described in BS 7671:2001.

Important:

The electrical supply requirements:-

The 2kW boilers and 6kW boiler supplies should meet the requirements of EN 61000-3.3.

The 9kW and 11kW boilers must be installed in premises having a service supply of $\geq 100A$ per phase and meet the requirements of IEC 60417-5855.

The 12kW boiler must be installed in premises having a system impedance of not more than $0.1939 + j0.1939\Omega$.

A double pole RCD with trip level sensitivity of 30mA can be used capable of breaking full load current to BS EN 61008:1994.

Note: RCD UNIT can be used as the isolating switch if mounted close enough to the boiler.

Miniature circuit breakers (MCB) **MUST** be fitted between RCD unit and boiler and RCD and any external controls. Refer to technical specification. For MCB ratings refer to wiring diagram.

It is important the correct size MCB is used in the supply from the RCD to the boiler. An additional MCB rated 6A will be required to supply the external controls.

Electrical Connections

WARNING: THIS APPLIANCE MUST BE EARTHED.

The mains connection block is located inside the boiler on a bracket at the top left hand side of the boiler which can be directly wired to the boiler MCB. Use the correctly rated cable.

Where the pump is wired directly back to the boiler both live and neutral connections must be used with the earth being wired back to the earth post. This is important as the pump is controlled by a switched neutral. This also applies to pumps being controlled by a relay.

IMPORTANT: CORRECT POLARITY MUST BE OBSERVED WHEN BRINGING THE MAINS SUPPLY INTO THE BOILER.

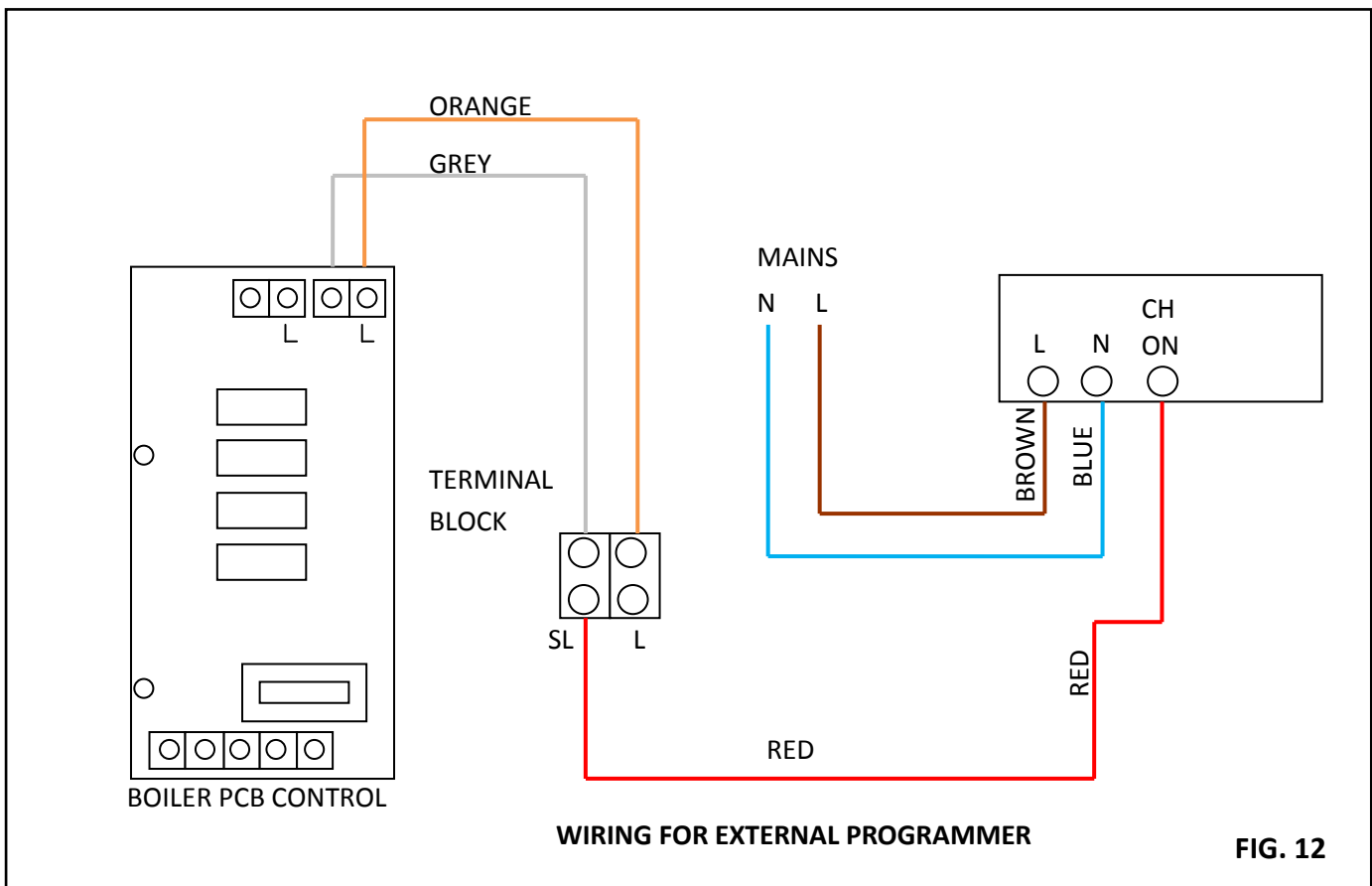

Wiring Instructions (continued)

3 Phase Supply Connections for 2 or more Boilers

MAINS SUPPLY CABLES

Connect each boiler to each phase.

CONTROL SIGNAL

Wire as shown in wiring diagram.

PUMP CONNECTIONS

The pump to be connected to one boiler only.

See wiring diagram.

IMPORTANT: ALL ELECTRICAL CONNECTIONS SHOULD BE CHECKED, LOOSE CONNECTIONS CAN CAUSE PROBLEMS.

WARNING: THIS APPLIANCE MUST BE EARTHED.

1. Any exposed pipe work must be earthed in accordance with IEE regulations.
2. On completion of installation all electrical work must be tested to IEE regulations and NICEIC inspection and completion certificate must be issued.

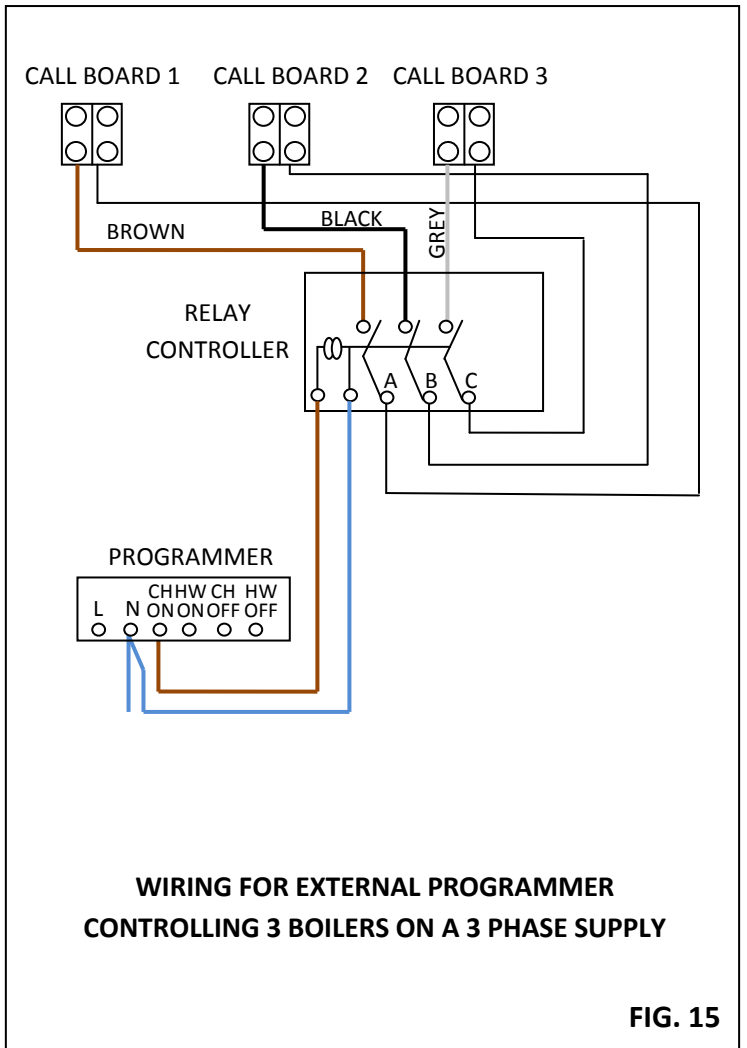
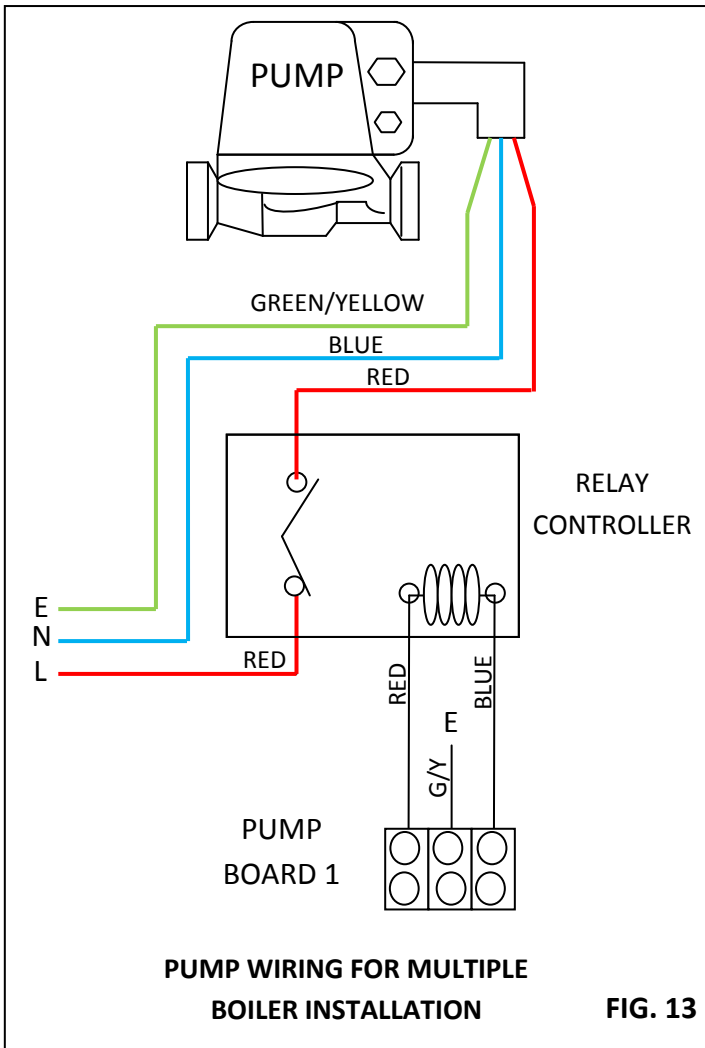
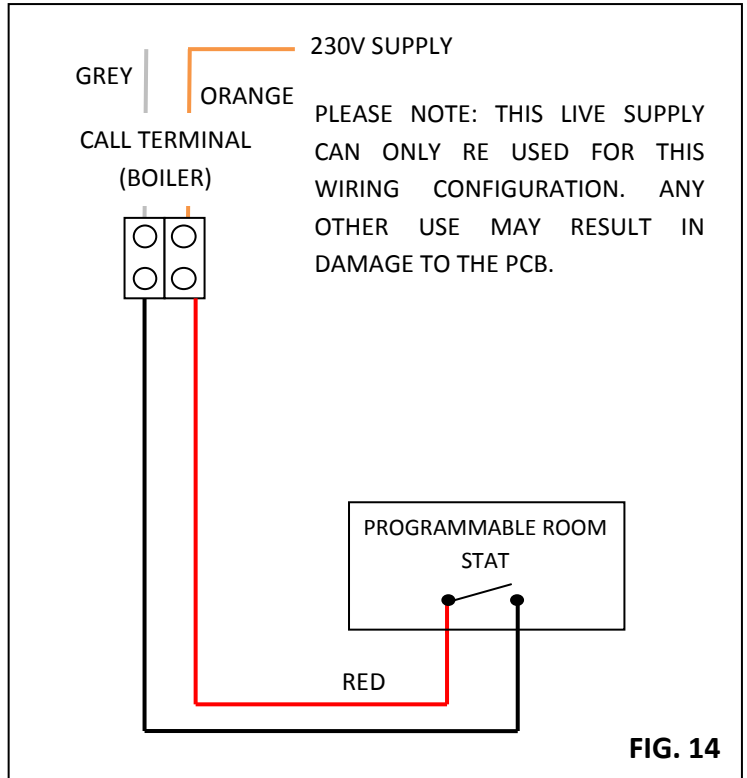

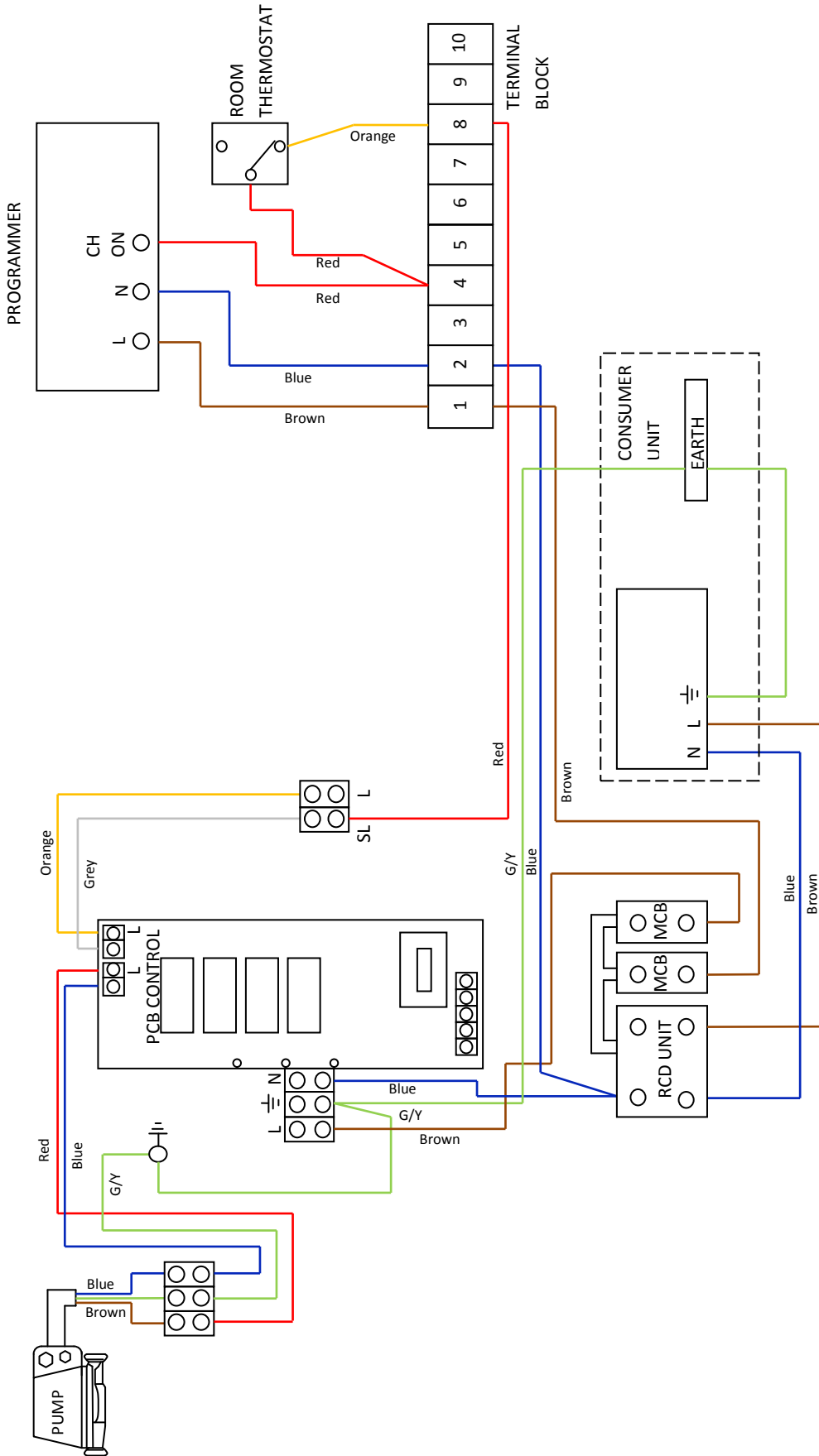

WIRING DIAGRAM FOR HEATING ONLY

FIG. 16

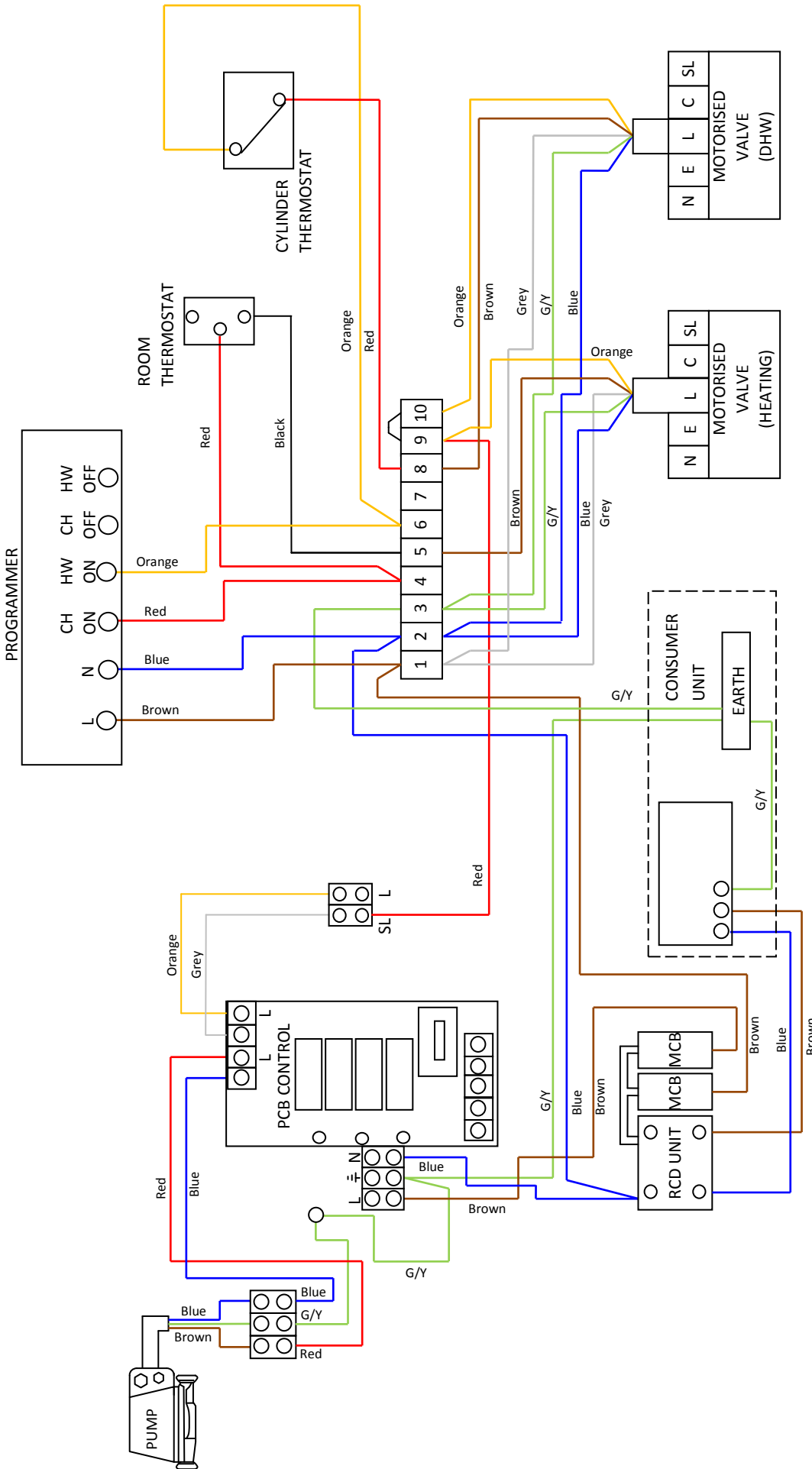

WIRING DIAGRAM FOR S PLAN CONTROL SYSTEM

FIG. 17

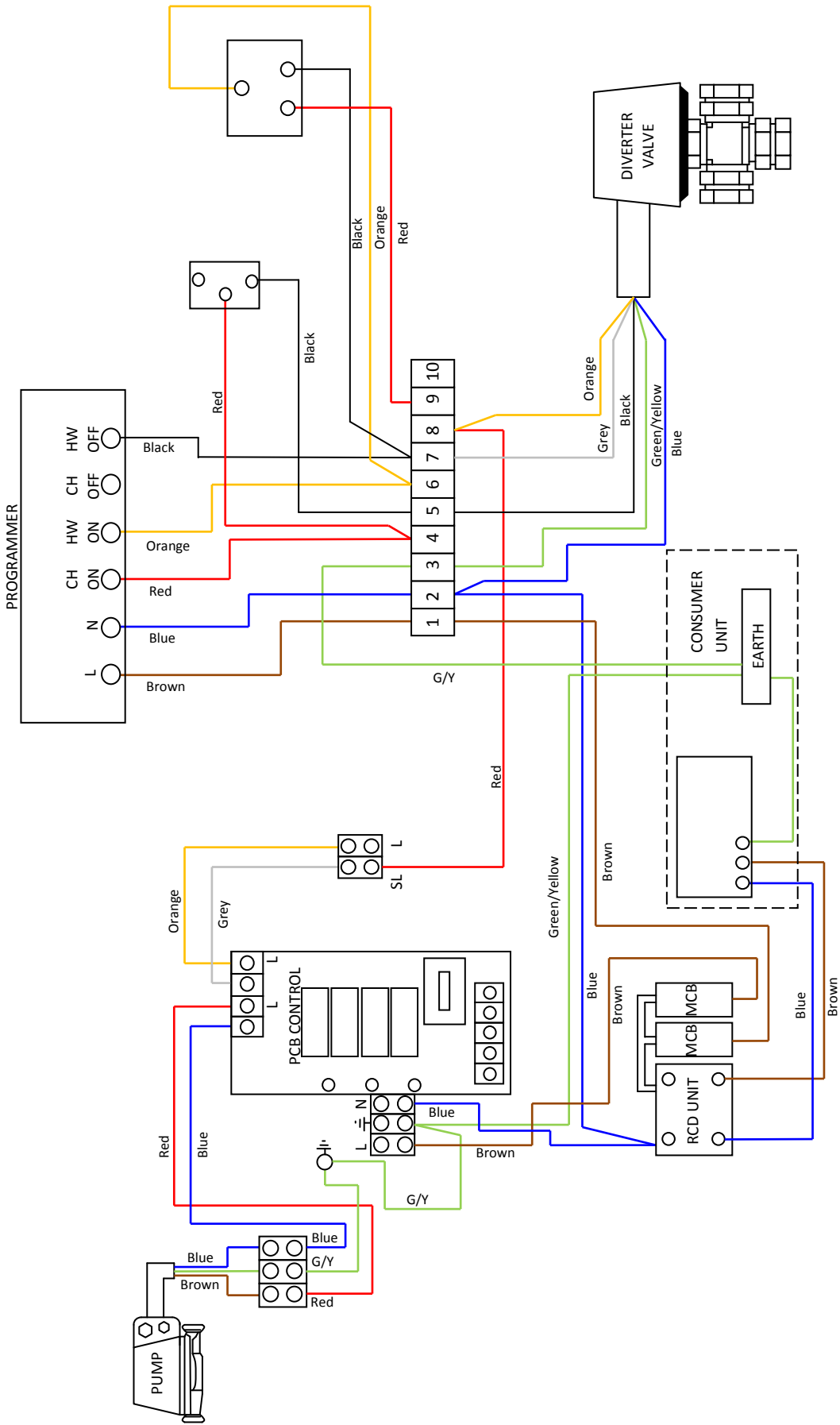

WIRING DIAGRAM FOR Y PLAN CONTROL SYSTEM

FIG. 18

This link needs to be left connected on installation.

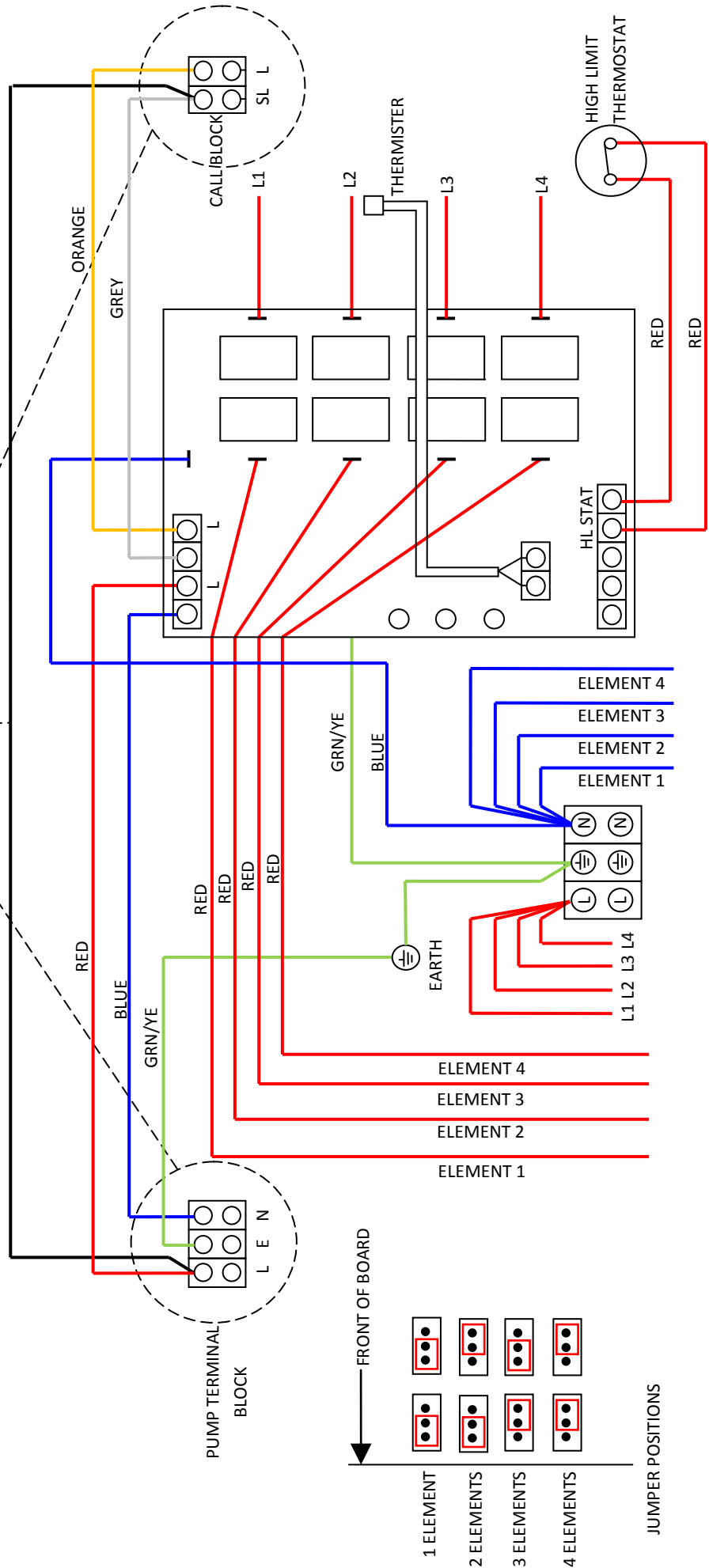
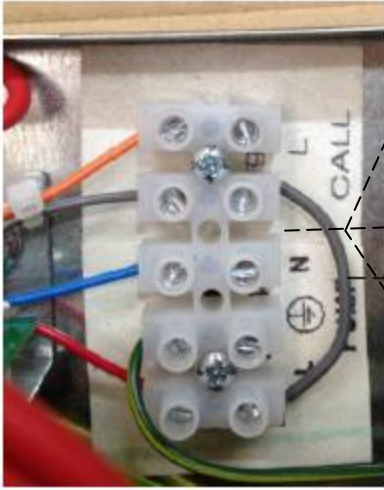

FIG. 19

11. Servicing Instructions

To ensure reliable operation of your Aztec electric boiler, it is recommended that you have your boiler serviced once a year.

The person(s), who services or carries out any remedial work, i.e. electrical fault finding, must have suitable engineering qualifications.

Isolate the mains supply before carrying out any service work.

1. Check all electrical connections on PCB and electric elements to ensure they are secure and clean.
2. Check electrical insulation on wiring.
3. Ensure all air grilles are clean and free from obstructions.
4. Inspects seals around elements and also the heat exchanger top and bottom flanges.

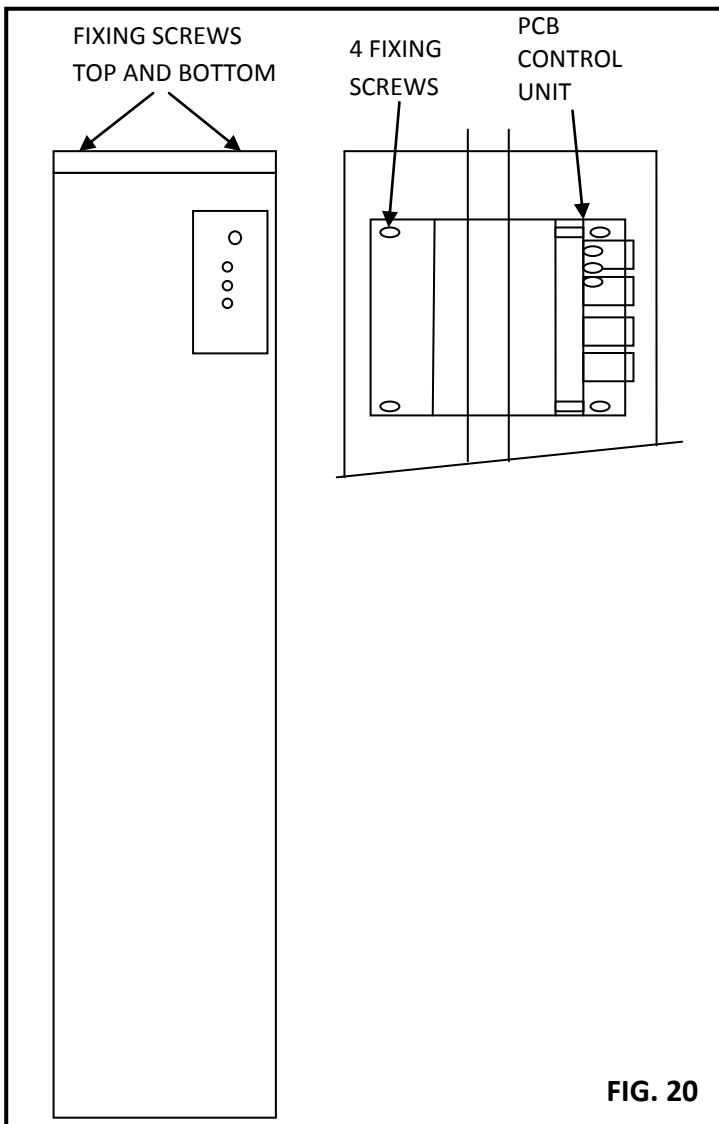

FIG. 20

12. Parts Replacement

11.1 Casing Removal

IMPORTANT

Isolate the mains electrical supply to the boiler before carrying out any maintenance work.

1. Isolate electrical supply to the boiler.

2. Remove 4 fixing screws securing front casing in position.
3. Slide top casing upwards this will allow front casing to slide forward.

IMPORTANT: All electrical connections should be checked. Loose connections can cause problems.

This boiler is fitted with a manual reset high limit thermostat. Before replacing any part, ensure that the thermostat does not require re-setting.

11.2 PCB Assembly Replacement

1. Ensure electrical supply is isolated to the boiler.
2. Remove the 4 fixing screws and washers (2 at top and 2 at bottom), lift up the top-plate and carefully slide off the front casing panel.
3. Disconnect the pump + call plug, the thermistor plug and the high limit stat plug.
4. Disconnect all element cables apart from the rear element. N.B. Take note of wiring arrangement before disconnecting.
5. Now remove the grey pipe insulation, it is now possible to disconnect the remaining element.
6. With all elements disconnected, again taking note of wiring arrangement, carefully disconnect and remove the element cables from the PCB.
7. **IMPORTANT: Care MUST be taken when handling the PCB.**
8. For ease of access disconnect from the main terminal block both the red + black cables and also the power input cables, leaving the earth cable connected.
9. Free both the pump and call terminal blocks by removing the terminal block fixing screws.
10. Finally remove the 4 fixing screws holding the PCB to the bracket.

11.3 High Limit Thermostat Replacement

1. Ensure electrical supply is isolated to the boiler.
2. The high limit thermostat can be found fixed to top front face of boiler.
3. Remove 2 terminal connectors from high limit thermostat, loosen retaining straps and slide thermostat out from behind.
4. **IMPORTANT: When replacing the thermostat ensure a heat sink compound is used between back of thermostat and face of the boiler (See Fig. 21 for positioning).**
5. Inspect retaining straps and replace where necessary.

11.4 Thermostat Replacement

1. Isolate the electrical supply to the boiler.
2. Thermistor is located fixed to the top front of the boiler above the high limit thermostat.
3. Disconnect from the PCB and slide out from behind the retaining strap.
4. **IMPORTANT: When replacing the thermistor ensure a heat sink compound is used between the thermistor and boiler body (See Fig 21 for positioning).**
5. Inspect retaining strap and replace where the necessary.
6. When replacing the front casing, ensure the thermostat control shaft passes through the hole in the front control panel.

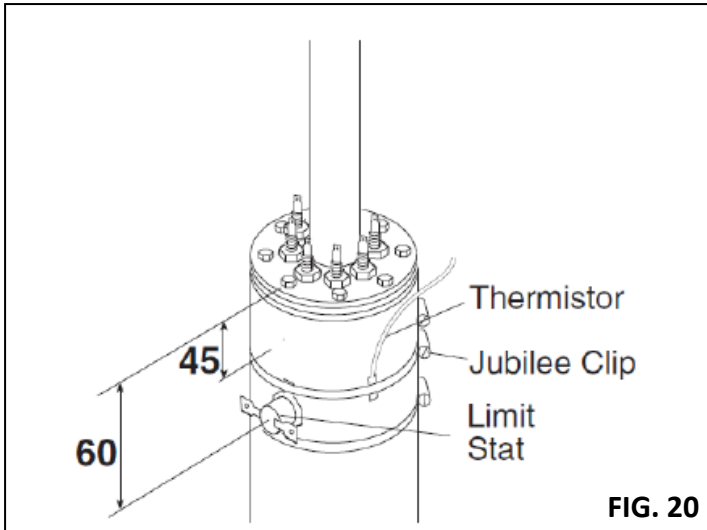

FIG. 20

11.5 Element Replacement

1. Isolate electrical supply to the boiler.
2. Drain down the system.
3. Disconnect the terminal connectors from the high limit thermostat.
4. Remove thermistor from behind the retaining strap.
5. Disconnect electrical elements and earth wire.
6. Disconnect compression fitting top and bottom of boiler.
7. Remove securing bracket on bottom of the boiler then carefully remove the top bracket.
8. Boiler unit can now be carefully removed.
9. Remove eight fixing screws on top flange and withdraw element assembly.
10. Remove bottom element positioning bracket.
11. Remove damaged element.
12. Refit in reverse order, ensure element seals are fitted.
13. Check for continuity through two terminals on each element.

IMPORTANT

Inspect all seals and change where necessary.

11. Fault Finding

Red LED permanently illuminated indicates one of the following faults.

High limit thermostat has operated or faulty electrical connections.

The high limit thermostat is fitted to the front top of the copper heat exchanger and secured in position with 2 retaining clamps. Check electrical connections on thermostat and PCB to check thermostat has not failed using a multi meter to check the continuity across the terminals of the thermostat. To reset press red button in the centre of the thermostat. Thermostat may have tripped due to one of the following:-

1. Faulty circulation pump.
2. Isolation valve on system closed.
3. Air trapped in system.
4. Out of calibration limit thermostat.
5. Temperature settings on PCB incorrect.
6. No water in system.

Thermistor

The thermistor is fitted to the front top of the heat exchanger and secured in position with a clamp; the other end terminates with a white connector that plugs on to the PCB. Check the connections on the board to make sure it is correctly fitted; also inspect the thermistor for any broken wires.

Mains Inlet Wiring

If the mains supply to the boiler is wired incorrectly on the inlet terminal block. Check polarity.

PCB Damage

Inspect the LED lights and the boiler temperature control adjuster for any damage to connections to the PCB controller.

Voltage Drop

If the voltage drops below 207 volts.

Red LED flashes indicates one of the following faults

Poor Electrical connection

Check the electrical connections to the elements and the PCB controller, a poor connection would show up as a fault.

Element Failure

To check elements for failure, disconnect each individual element and check continuity through the element, if there is continuity between the two terminals the element is ok. Check each element individually replacing the electrical connectors after testing.

Element Cables

If there is a break in the element cable, this would show up as a fault. Check all element cables and connections.

Jumpers

Are the jumpers set correctly (see Fig. 19).

Green LED

If the green LED is illuminated but the boiler is not functioning, check that any external controls fitted are calling for heat.

Blown fuse on Board

If there is power to the boiler but no LED illuminated then the fuse on the PCB may have blown. The fuse is located at the top edge of the PCB. (Fuse type 20mm 1A anti-surge Bessman type S560). The fuse may have blown due to one of the following:-

1. When multiple boilers are fitted and a larger pump is used.
2. If the call terminal block is used to supply power to any ancillary controls.

RCD Unit Trips

Check that the RCD unit is correctly rated for the boiler size. If under sized then change.

Inspect the mains terminal block for earth continuity, if the element is found to be faulty then fit a new element.

Thermistor Values

Temperature	Resistor Value
0	32554
5	25339
10	19872.2
15	15698.5
20	12487.7
25	10000
30	8069.1
35	6534.7
40	5329.9
45	4371.7
50	3605.3
55	2988.7
60	2490
65	2084.4
70	1753
75	1480.9

NO HEAT – PERMANENT GREEN LIGHT

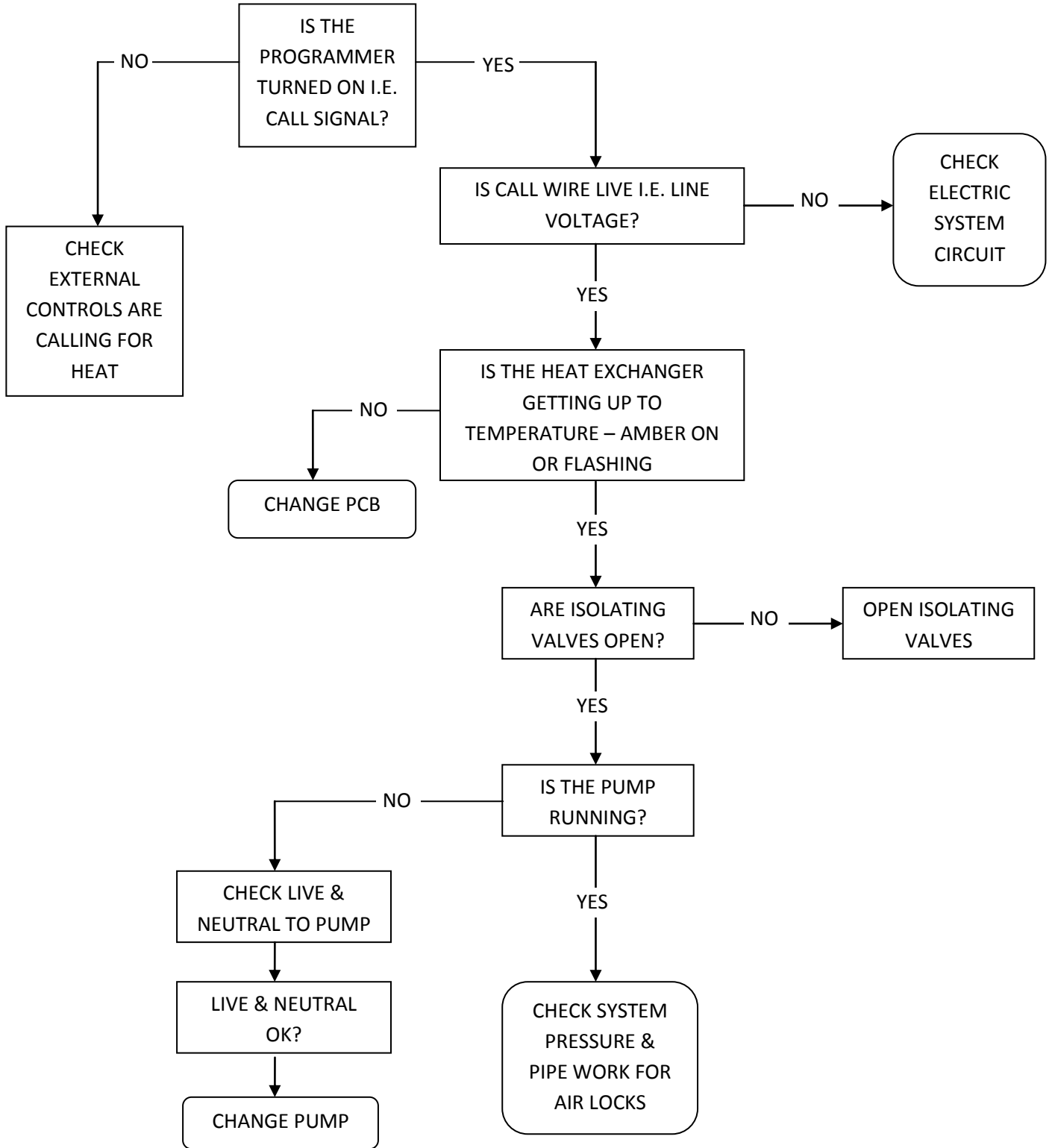

FLASHING RED LIGHT

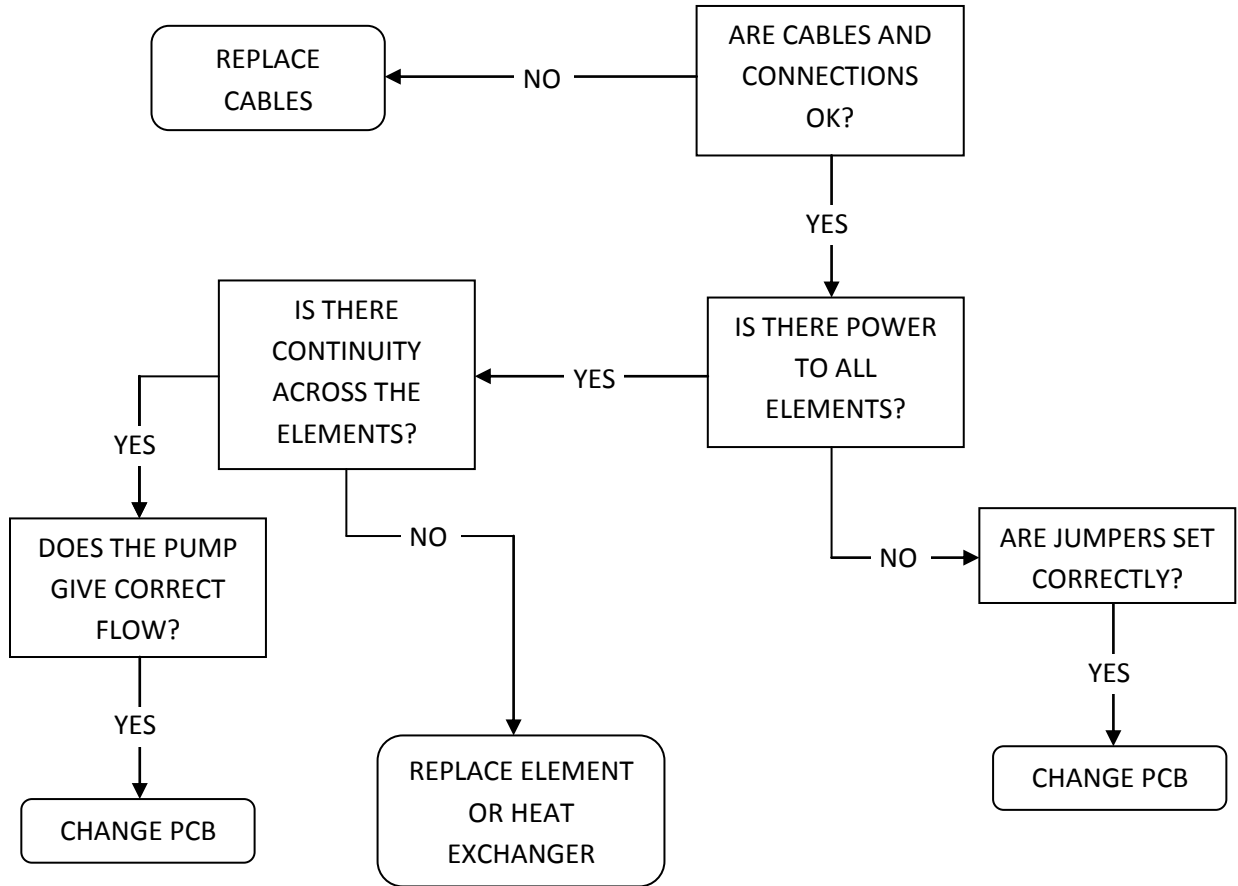

PERMANENT RED LIGHT

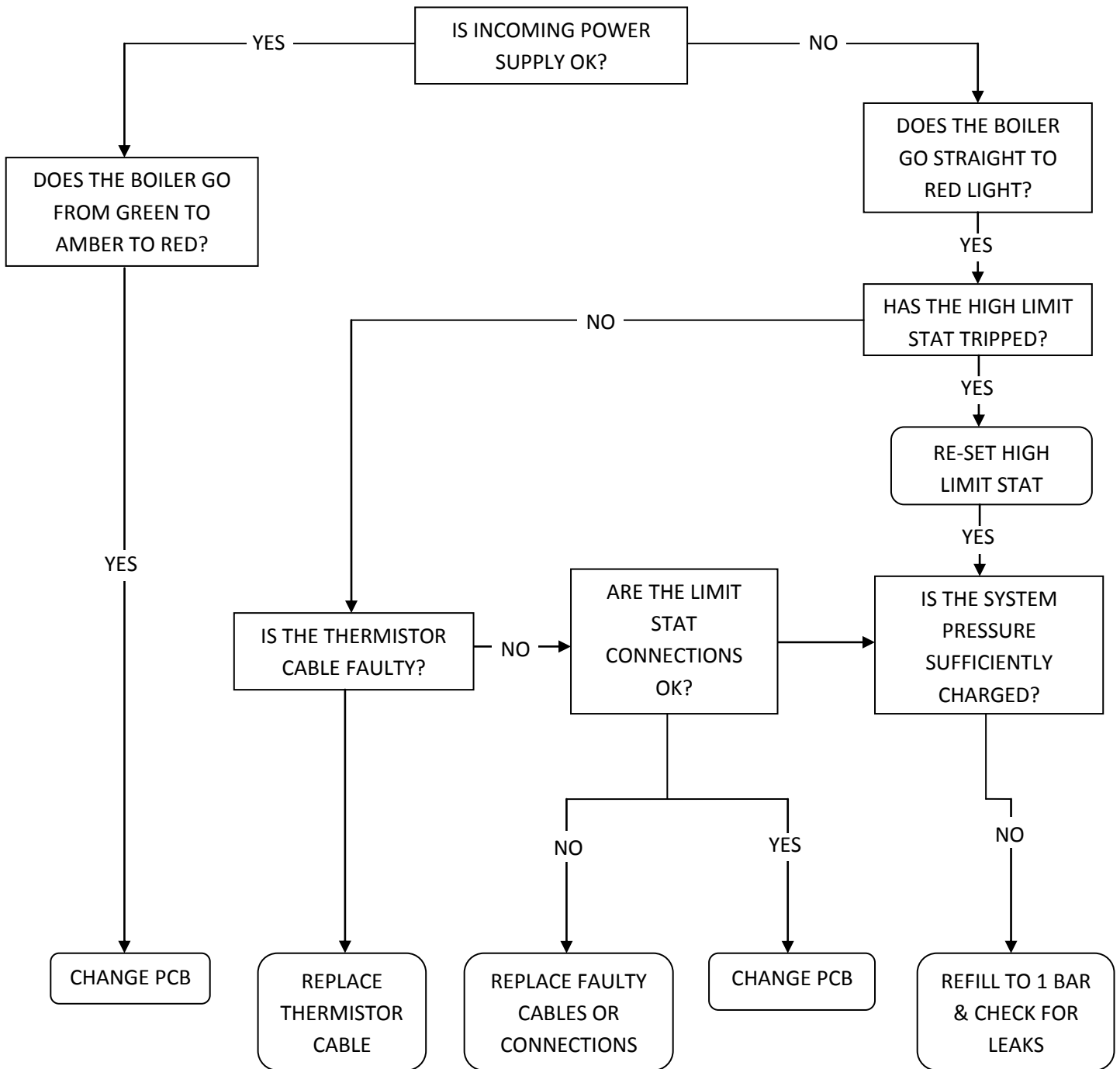

NO GREEN LIGHT

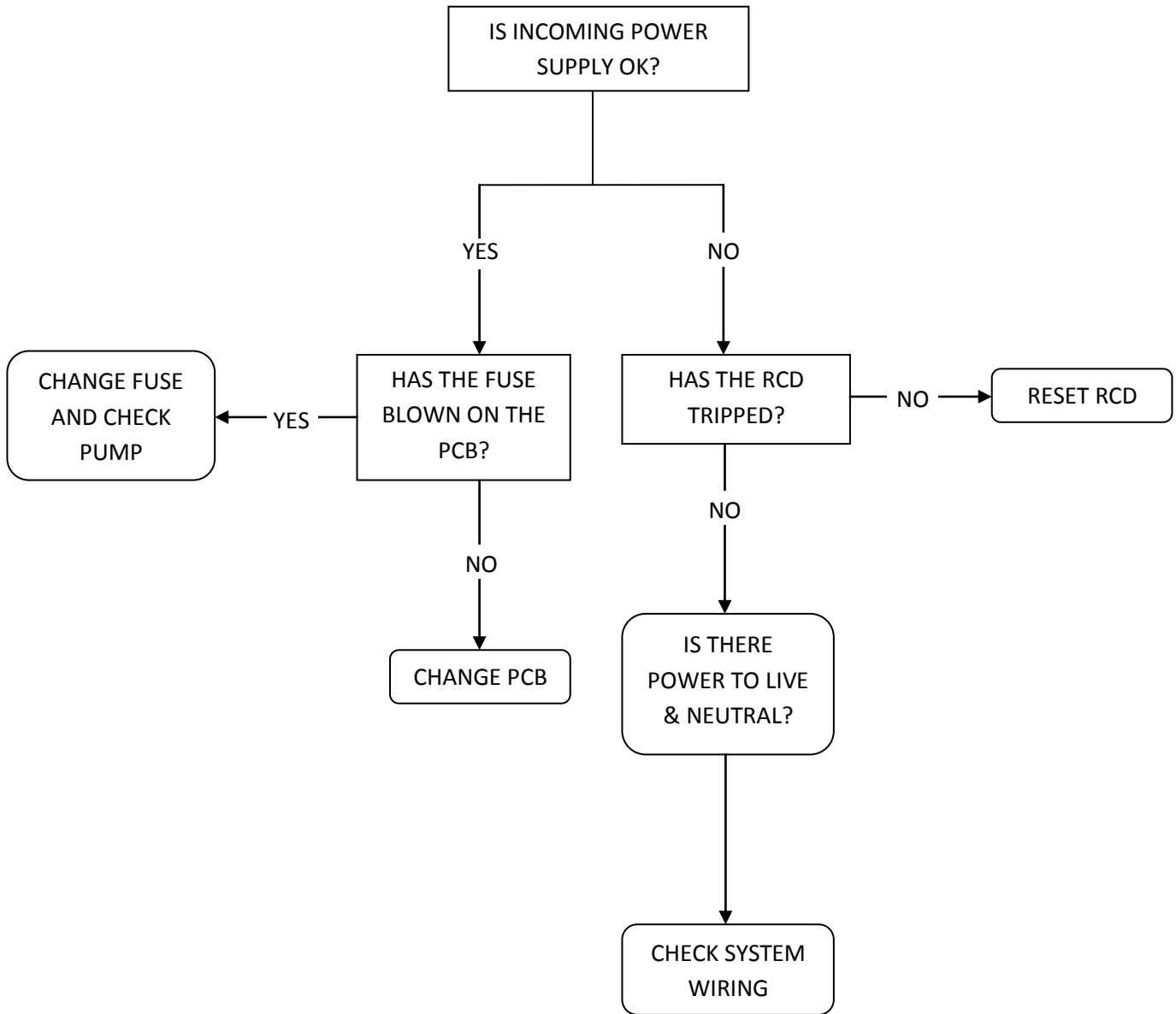

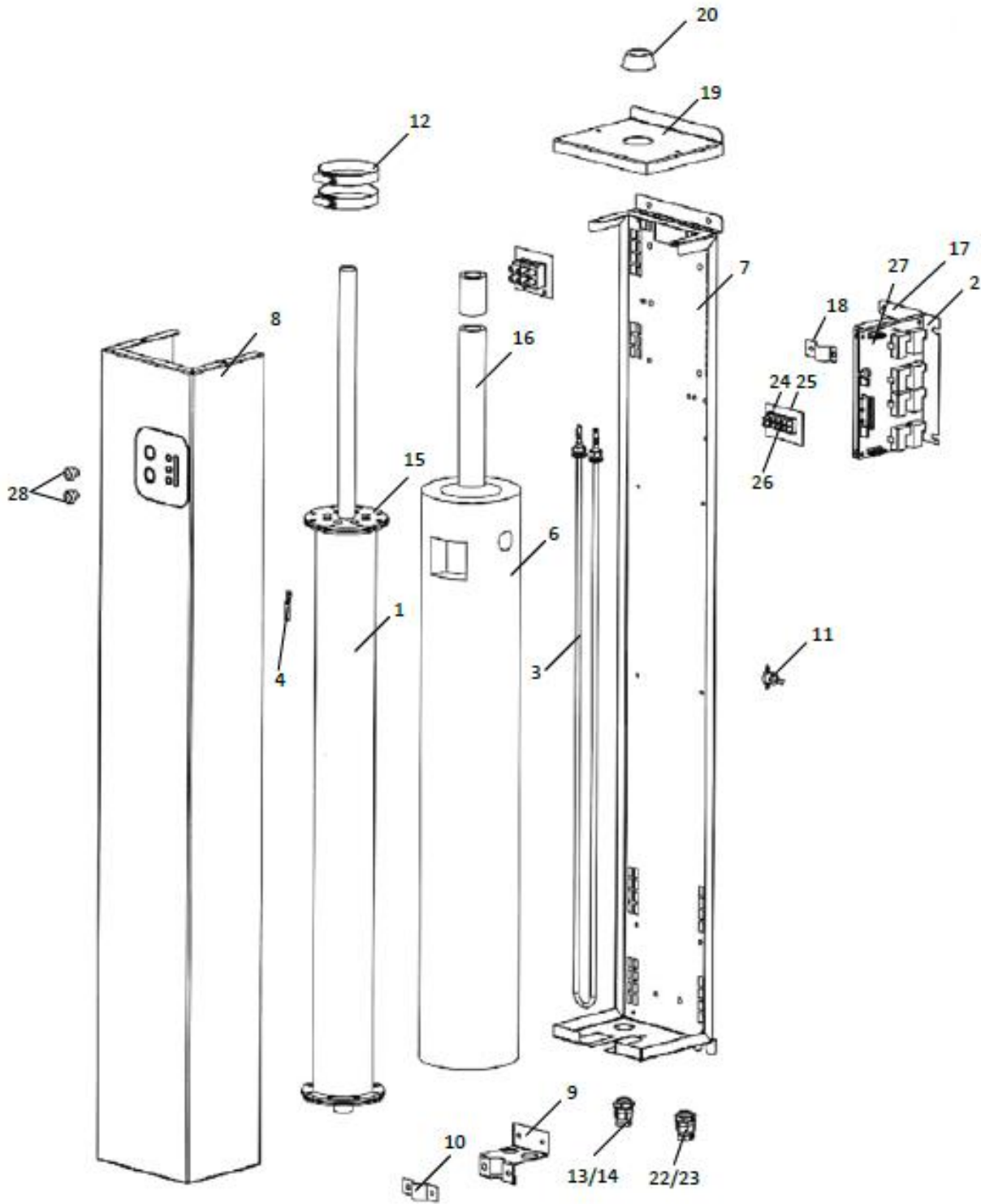

ITEM	DESCRIPTION	QTY	2kW	6kW	9kW	11kW	12kW
1	Heat Exchanger Assembly	1	221881	221882	221883	221884	221880
2	PCB Assembly	1	211559	211559	211559	211559	211559
3	Element	1	222641	-	-	-	-
		3	-	221802	-	-	-
		3	-	-	221850	-	-
		3	-	-	-	221850	-
		1	-	-	-	221802	-
		4	-	-	-	-	221850
4	Thermistor	1	221824	221824	221824	221824	221824
6	Tube Insulation	1	221863	221826	221843	221843	221843
7	Back Casing Assembly	1	221865	221830	221845	221845	221845
8	Front Casing Assembly	1	221867	221821	221847	221847	221847
9	Bottom Pipe Bracket	1	221815	221815	221815	222093	222093
10	Pipe Bracket	1	221814	221814	221814	221814	221814
11	High Limit Thermostat	1	221825	221825	221825	221825	221825
12	Jubilee Clip	2	95256	95256	95256	95256	95256
13	Cable Gland	1	210796	210796	210796	210796	210796
14	Locknut	1	210797	210797	210797	210797	210797
15	Gasket	1	221807	221807	221807	221807	221807
16	22mm Pipe Insulation	1	99285	99285	99285	99285	99285
17	Duct Top	1	221793	221793	221793	221793	221793
18	Top Pipe Bracket	1	221796	221796	221796	221796	221796
19	Top Cap	1	221791	221791	221791	221791	221791
20	Snap In Protection Grommet	1	221787	221787	221787	221787	221787
22	Cable Gland	1	210796	221825	221887	221887	221887
23	Locknut	1	210797	221825	221887	221887	221887
24	Label Call	1	221965	221965	221965	221965	221965
25	Label Pump	1	221964	221964	221964	221964	221964
26	Terminal Block	1	96278	96278	96278	96278	96278
27	Fuse 1A	1	211563	211563	211563	211563	211563
28	Switch Assembly	1	211562	211562	211562	211562	211562
	Wiring Harness	1	-	221798	221798	221799	221799





TRIANCO

T R Engineering Ltd
Unit 7, Newton Chambers Way
Thornccliffe Industrial Estate
Chapelton
Sheffield
S35 2PH

Tel: 0114 257 2300

Fax: 0114 257 1419

E-mail: info@trianco.co.uk

Web: www.trianco.co.uk

© T R Engineering Ltd

Copyright in this brochure and the drawings and illustrations contained in it is vested in T R Engineering Ltd and neither the brochure nor any part thereof may be reproduced without prior written consent.

T R Engineering Ltd's policy is one of continuous research and development. This may necessitate alterations to this specification.

221827 May 2014