



TRIANCO

BRINGING HEAT TO LIFE



Activair Pro

Air Source Heat Pump

Installation Operation and Service Manual

**PLEASE READ THESE INSTRUCTIONS CAREFULLY BEFORE INSTALLING
AND OPERATING THIS APPLIANCE**

TO BE RETAINED BY HOUSEHOLDER

Contents

Introduction	3
Health and Safety	3
Safety Precautions	4-5
After Sales Service Information	6
Choosing the Correct Size Unit	7-9
Unpacking	10
Dimensions	10
Installation Space and Clearances	11
Siting the Unit	11
Panel Removal	12
Electrical Wiring Diagram	13
Power Supply Connection	14
Electrical Connections	14
User Interface and DTU connection	15
System Requirements	16
Expansion Vessel Capacity	17
System Schematics	18-21
Inspection before operation	22
Commissioning	23-24
Warm Link App Control	24
User Interface	25-32
Weather Compensation	33
Maintenance	34-35
Refrigerant Charge	36
Fault Diagnosis	37
Information Codes	38-41
Technical Details	42
Commissioning Checklist	43-44
Notes	45-47

INTRODUCTION

This manual includes the necessary information about the unit. Please read this manual carefully before you install, operate, and maintain the unit. This manual is intended for professional installers.

By Fitting this Activair Pro High Temperature Air Source Heat Pump, you agree:

- **The unit has been received in good condition.**
- **You have carried out a heat loss calculation, consulted the heat pumps data and are sure that this heat pump is suitable for your domestic installation.**
- **You have carried out a load and voltage test to determine the correct size of breaker to be used.**
- **You meet the requirements of the appropriate Building Regulations.**

HEALTH AND SAFETY

INFORMATION FOR THE USER, INSTALLER AND SERVICE ENGINEER

Under the Consumer Protection Act 1987 and the Health and Safety at Work Act 1974, it is a requirement to provide information on substances hazardous to health (COSHH Regulations 1998).

TR Engineering takes every reasonable care to ensure that its products are designed and constructed to meet these safety requirements when the products are professionally installed and used. To fulfil the requirements, products are comprehensively tested and examined before despatch.

When working on the appliance, it is the responsibility of the user or engineer to ensure that personal protective clothing or equipment appropriate to parts that could be considered hazardous or harmful is worn.

This appliance may contain some of the items below:

Glass rope, mineral wool, insulation pads, ceramic fibre, and glass insulation.

When handling, avoid inhalation and contact with eyes. These may be harmful and cause irritation to the skin, eyes, nose, or throat. Use disposable gloves, face masks and eye protection.

After handling, wash hands and other exposed areas. When disposing of materials, limit dust and the risk of inhalation by using water spray. Ensure materials are securely wrapped.

Seek urgent medical attention if inhaled or ingested. Exposure to eyes and skin should be followed by immediate cleansing of the affected areas and medical attention if necessary.

Glues, Sealants and Paints

The glues, sealants and paints used present no known hazards when the appliance is used in the manner for which it is intended.

This Activair High Temperature Heat Pump uses R290 refrigerant.

Precautions should be taken when installing and working on appliances that contain R290 refrigerant.

SAFETY PRECAUTIONS

To Prevent Injury to the user, other people, or property damage the following instructions must be followed.

Incorrect operation due to ignoring of instructions may cause harm or damage.

Install the unit only when it complies with local regulations, by-laws, and standards. Check the mains voltage and frequency. This unit is only suitable for earthed supplies.

The following safety precautions should always be considered:

- Be sure to read the following WARNING before installing the unit.
- Be sure to observe the cautions specified here as they include important items related to safety.
- After reading these instructions, be sure to keep it together with the manual in a handy place for future reference.

WARNING

Only to be installed by a professional person.

Incorrect installation could cause injury due to fire, electric shock, the unit falling or leakage of water. Consult the dealer from whom you purchased the unit or a specialized installer.

Install the unit securely in place.

When insufficiently installed, the unit could fall causing injury.

Use the specified electrical wires and attach the wires firmly to the terminal board (connection in such a way that the stress of the wires is not applied to the terminals).

Incorrect connection and fixing could cause a fire.

Be sure to use the provided or specified parts for the installation work.

The use of defective parts could cause an injury due to fire, electric shocks, the unit falling etc.

Perform the installation securely and please refer to the installation instructions.

Incorrect installation could cause an injury due to fire, electric shocks, the unit falling, leakage of water etc.

Perform electrical work according to the installation manual.

If the capacity of the power circuit is insufficient or there is an incomplete electrical circuit, it could result in a fire or an electric shock.

The unit must always have an earthed connection.

If the power supply is not earthed, you may not connect the unit.

Never use an extension cable to connect the unit to the electric power supply.

If there is no suitable, earthed supply available, have one installed by a qualified electrician.

Do not move/repair the unit yourself.

Improper movement or repair on the unit could lead to water leakage, electrical shock, injury, or fire. Have any repairs and/or maintenance only carried out by a recognized service engineer.

Do not plug or unplug the power supply during operation.

Risk of fire or an electric shock.

Do not touch/operate the unit with wet hands.

Risk of fire or an electric shock.

Do not place a heater or other appliances near the power cable.

Risk of fire or an electric shock.

Be cautious that water could not be poured into the product directly, do not allow water to run into electric parts.

Risk of fire or an electric shock.

If the supply cable is damaged, it must be replaced by qualified person to avoid a hazard.

This appliance has not been designed for use by persons (including children) with reduced physical, sensorial, or mental faculties or by persons without any experience or knowledge of heating systems, unless they act under the safety and supervision of a responsible person or have received prior training concerning the use of the appliance.

Children should be supervised to ensure that they do not play with the appliance.



IF THE PRODUCT IS NOT TO BE USED FOR AN EXTENDED PERIOD OF TIME, WE STRONGLY RECOMMEND NOT TO SWITCH 'OFF' THE POWER SUPPLY OF THE UNIT.



IF THE POWER IS NOT SUPPLIED, THE ANTI-FREEZE FUNCTION WILL NOT BE PERFORMED.



CAUTION

Do not install the unit in a place where there is a chance of flammable gas leaks.

If there is a gas leak and gas accumulates in the area surrounding the unit, it could cause an explosion.

Perform the drainage/piping work according to the installation instruction.

Do not clean the unit when the power is 'on.'

Always shut 'off' the power when cleaning or servicing the unit. If not, it could cause electrical shock.

Do not continue to run the unit when there is a suspected fault.

The power supply needs to be shut 'off' to stop the unit; otherwise, this may cause an electrical shock or fire.

Be cautious when unpacking and installing the product.

Sharp edges could cause injury. Especially watch the edges and the fins on the heat exchanger of the product.

Always check for gas (refrigerant) leakage after installation or repair of product.

Low refrigerant levels may cause failure of the product.

Keep level even when installing the product.

Do not place hands or fingers into the fan, or evaporator.

The ventilator runs at high speed; this could cause significant injury.

Keep the unit upright, even when transporting and installing the product.

TR ENGINEERING LTD CUSTOMER AFTER SALES SERVICE INFORMATION

The Heat Pump comes with a 5 Year warranty, providing the Heat Pump is registered within 30 days from the date of installation. 3 Years Parts and Labour, Years 4 and 5, Parts only. Register online at:

<https://trianco.co.uk/information/product-registration>

Terms and Conditions apply, please see Trianco web site for details.

The Heat Pump must be serviced annually by a suitably qualified MCS registered Heat Pump Engineer to qualify for warranty after the first year.

Please note you will require the full Heat Pump serial number to be able to register the unit. The serial number is located on the right-hand side of the Heat Pump and can also be found on the box the Heat Pump came in.

A step-by-step guide to reporting a fault with your appliance.

A qualified field SERVICE ENGINEER is available to attend a breakdown or manufacturing fault occurring whilst the appliance is under warranty.

The appliance must be made available for service during normal working hours, Monday to Friday (no weekend work or bank holidays accepted).

A charge will be made where:

- Our Field Service Engineer finds no fault with the appliance.
- The cause of a breakdown is due to other parts of the plumbing/heating system or with equipment not supplied by TR Engineering Ltd.
- Where the appliance falls outside the warranty period.
- The appliance has not been correctly installed, as recommended (see installation, operating and servicing instructions.)

NOTE: Over 50% of all service calls made are found to have no appliance fault.

What to do in the event of an appliance fault or breakdown:

Step 1: Always contact your installer in the first instance, who must thoroughly check all their work PRIOR to requesting a service visit from TR Engineering LTD.

Step 2: If your appliance has developed an in-warranty fault your installer should contact TR Engineering LTD for assistance from site. Please quote the serial number at the beginning of the call.

What happens if my Installer/engineer is unavailable?

Step 3: Contact TR Engineering LTD. We will provide you with the name and telephone number of our Service Agent. However, a charge may apply if the fault is not covered by the appliance warranty (payment will be requested on site by our independent Service Agent).

PLEASE NOTE: UNAUTHORISED INVOICES FOR ATTENDANCE AND REPAIR WORK CARRIED OUT ON THIS APPLIANCE BY ANY THIRD PARTY WILL NOT BE ACCEPTED BY TR ENGINEERING LTD

SERVICE CENTRE AND TECHNICAL SUPPORT

Tel: 0114 257 2300 Fax: 0114 257 1419

Hours of Business

Monday to Friday 8.30am - 5pm

Choosing the correct size unit.

Sizing the heat pump is extremely important.

The heat pump is intended for domestic use only.

Match the correct heat pump for the heat requirement.

Pay attention to the heat pump output at lower ambient temperatures.

Pay attention to the heat pump output at Higher flow temperature settings.

Activair Pro 6kW													
Max. Heating Capacity (kW)													
	Ambient Temperature (°C)												
Water outlet(°C)	-30	-25	-20	-15	-10	-7	-5	2	7	10	15	20	25
25	3.77	4.36	5.11	6.00	6.00	6.00	6.00	6.00	6.00	6.00	6.00	6.00	6.00
35	3.66	4.23	4.96	5.90	6.00	6.00	6.00	6.00	6.00	6.00	6.00	6.00	6.00
40	3.62	4.19	4.89	5.83	6.00	6.00	6.00	6.00	6.00	6.00	6.00	6.00	6.00
45	3.58	4.14	4.81	5.76	6.00	6.00	6.00	6.00	6.00	6.00	6.00	6.00	6.00
50	3.57	4.13	4.73	5.66	6.00	6.00	6.00	6.00	6.00	6.00	6.00	6.00	6.00
55	3.56	4.11	4.64	5.55	6.00	6.00	6.00	6.00	6.00	6.00	6.00	6.00	6.00
60	3.07	3.42	4.32	5.17	6.00	6.00	6.00	6.00	6.00	6.00	6.00	6.00	6.00
65	/	3.25	3.95	4.60	5.34	5.57	5.79	6.00	6.00	6.00	6.00	6.00	6.00
70	/	/	3.42	3.99	4.52	4.71	4.89	5.85	6.00	6.00	6.00	6.00	6.00
75	/	/	/	3.77	4.27	4.45	4.66	5.08	5.55	5.76	6.00	6.00	6.00
80	/	/	/	/	3.95	4.29	4.41	4.80	5.25	5.45	5.90	6.00	/
Power Input (kW)													
	Ambient Temperature (°C)												
Water outlet(°C)	-30	-25	-20	-15	-10	-7	-5	2	7	10	15	20	25
25	2.45	2.05	2.11	2.20	1.92	1.77	1.68	1.58	1.12	1.06	0.93	0.81	0.73
35	2.74	2.29	2.36	2.46	2.20	2.06	1.94	1.52	1.23	1.20	1.14	1.05	0.93
40	2.91	2.43	2.53	2.63	2.41	2.26	2.05	1.63	1.39	1.31	1.26	1.17	1.07
45	3.07	2.57	2.69	2.80	2.59	2.48	2.25	1.74	1.58	1.51	1.39	1.28	1.24
50	3.32	2.78	2.85	2.99	2.78	2.63	2.51	1.95	1.81	1.75	1.55	1.44	1.38
55	3.56	2.98	3.03	3.18	3.05	2.84	2.70	2.07	1.89	1.82	1.72	1.68	1.58
60	3.06	2.82	3.01	3.16	3.29	3.02	2.92	2.40	2.08	2.01	1.89	1.82	1.76
65	/	3.07	2.92	3.06	3.27	3.26	3.24	2.75	2.62	2.60	2.33	2.25	2.02
70	/	/	2.90	3.04	3.14	3.19	3.17	3.25	3.26	3.20	2.74	2.66	2.42
75	/	/	/	3.38	3.49	3.54	3.55	3.46	3.47	3.54	3.56	3.48	2.91
80	/	/	/	/	3.35	3.55	3.57	3.47	3.48	3.55	3.57	3.50	/
COP(kW/kW)													
	Ambient Temperature (°C)												
Water outlet(°C)	-30	-25	-20	-15	-10	-7	-5	2	7	10	15	20	25
25	1.54	2.13	2.42	2.73	3.12	3.39	3.58	3.80	5.35	5.64	6.45	7.38	8.28
35	1.34	1.85	2.10	2.40	2.73	2.91	3.09	3.95	4.88	5.00	5.29	5.69	6.47
40	1.25	1.72	1.93	2.22	2.49	2.65	2.93	3.68	4.33	4.58	4.74	5.13	5.60
45	1.17	1.61	1.79	2.06	2.31	2.42	2.67	3.45	3.80	3.99	4.32	4.67	4.83
50	1.08	1.49	1.66	1.89	2.16	2.28	2.40	3.08	3.31	3.43	3.87	4.18	4.34
55	1.00	1.38	1.53	1.75	1.97	2.11	2.22	2.90	3.17	3.30	3.50	3.57	3.80
60	1.00	1.21	1.43	1.64	1.82	1.98	2.05	2.50	2.89	2.99	3.18	3.30	3.41
65	/	1.06	1.35	1.50	1.63	1.71	1.79	2.18	2.29	2.31	2.57	2.66	2.97
70	/	/	1.18	1.31	1.44	1.48	1.54	1.80	1.84	1.88	2.19	2.26	2.48
75	/	/	/	1.12	1.23	1.26	1.31	1.47	1.60	1.63	1.69	1.72	2.06
80	/	/	/	/	1.18	1.21	1.23	1.39	1.51	1.54	1.65	1.71	/

Activair Pro 12kW													
Max. Heating Capacity (kW)													
	Ambient Temperature (°C)												
Water outlet(°C)	-30	-25	-20	-15	-10	-7	-5	2	7	10	15	20	25
25	8.07	9.14	9.71	11.41	12.00	12.00	12.00	12.00	12.00	12.00	12.00	12.00	12.00
35	7.43	8.65	9.87	11.35	12.00	12.00	12.00	12.00	12.00	12.00	12.00	12.00	12.00
40	6.86	8.41	9.95	11.34	12.00	12.00	12.00	12.00	12.00	12.00	12.00	12.00	12.00
45	6.29	8.16	10.03	11.33	12.00	12.00	12.00	12.00	12.00	12.00	12.00	12.00	12.00
50	6.18	8.08	10.11	11.39	12.00	12.00	12.00	12.00	12.00	12.00	12.00	12.00	12.00
55	6.05	8.00	9.72	11.44	11.94	12.00	12.00	12.00	12.00	12.00	12.00	12.00	12.00
60	6.00	7.91	8.25	10.19	11.18	12.00	12.00	12.00	12.00	12.00	12.00	12.00	12.00
65	5.99	7.72	7.79	9.58	10.42	11.13	11.59	11.40	12.00	12.00	12.00	12.00	12.00
70	/	/	7.20	8.43	9.66	10.29	10.69	12.24	12.00	12.00	12.00	12.00	12.00
75	/	/	/	/	8.72	10.18	10.65	11.59	12.00	12.00	12.00	12.00	12.00
80	/	/	/	/	/	10.06	10.32	11.23	12.00	12.00	12.00	12.00	/
Power Input (kW)													
	Ambient Temperature (°C)												
Water outlet(°C)	-30	-25	-20	-15	-10	-7	-5	2	7	10	15	20	25
25	4.21	4.37	4.43	4.67	4.72	4.66	4.00	3.71	2.75	2.26	1.86	1.66	1.51
35	4.43	4.47	4.75	4.81	4.96	4.75	4.16	3.92	2.89	2.62	2.38	2.05	1.77
40	4.53	4.59	5.10	5.15	5.32	4.84	4.54	4.42	3.27	3.04	2.66	2.32	2.04
45	4.62	4.70	5.46	5.49	5.68	4.93	4.92	4.53	3.27	3.11	2.95	2.59	2.30
50	4.93	5.11	5.83	5.90	6.04	5.35	5.30	4.75	3.53	3.37	3.23	2.86	2.59
55	5.18	5.43	5.87	6.31	6.15	6.01	5.63	5.23	3.82	3.67	3.51	3.14	2.85
60	5.33	5.68	5.23	5.77	5.85	6.11	5.80	5.41	4.13	3.99	3.73	3.48	3.12
65	5.57	5.93	5.14	5.66	5.80	5.97	5.87	5.43	4.50	4.37	4.23	3.85	3.70
70	/	/	5.32	5.78	6.24	6.23	6.23	6.25	5.42	5.34	4.80	4.28	3.94
75	/	/	/	/	6.66	6.72	6.66	6.50	5.85	5.80	5.26	4.71	4.59
80	/	/	/	/	/	7.29	7.26	7.15	6.22	6.06	5.73	5.11	/
COP(kw/kw)													
	Ambient Temperature (°C)												
Water outlet(°C)	-30	-25	-20	-15	-10	-7	-5	2	7	10	15	20	25
25	1.92	2.09	2.19	2.44	2.54	2.58	3.00	3.23	4.36	5.31	6.45	7.23	7.95
35	1.68	1.94	2.08	2.36	2.42	2.53	2.88	3.06	4.15	4.58	5.04	5.85	6.78
40	1.51	1.83	1.95	2.20	2.26	2.48	2.64	2.71	3.67	3.95	4.51	5.17	5.88
45	1.36	1.74	1.84	2.06	2.11	2.43	2.44	2.65	3.67	3.86	4.07	4.63	5.22
50	1.25	1.58	1.73	1.93	1.99	2.24	2.26	2.53	3.40	3.56	3.72	4.20	4.63
55	1.17	1.47	1.66	1.81	1.94	2.00	2.13	2.29	3.14	3.27	3.42	3.82	4.21
60	1.13	1.39	1.58	1.77	1.91	1.96	2.07	2.22	2.91	3.01	3.22	3.45	3.85
65	1.08	1.30	1.52	1.69	1.80	1.86	1.97	2.10	2.67	2.75	2.84	3.12	3.24
70	/	/	1.35	1.46	1.55	1.65	1.72	1.96	2.21	2.25	2.50	2.80	3.05
75	/	/	/	/	1.31	1.51	1.60	1.78	2.05	2.07	2.28	2.55	2.61
80	/	/	/	/	/	1.38	1.42	1.57	1.93	1.98	2.09	2.35	/

Activair Pro 17kW													
Max. Heating Capacity (kW)													
	Ambient Temperature (°C)												
Water outlet(°C)	-30	-25	-20	-15	-10	-7	-5	2	7	10	15	20	25
25	5.67	9.35	12.10	14.69	16.02	17.00	17.00	17.00	17.00	17.00	17.00	17.00	17.00
35	5.62	9.25	12.03	14.41	15.91	17.00	17.00	17.00	17.00	17.00	17.00	17.00	17.00
40	5.60	9.23	12.00	14.35	15.86	17.00	17.00	17.00	17.00	17.00	17.00	17.00	17.00
45	5.58	9.21	11.96	14.28	15.80	17.00	17.00	17.00	17.00	17.00	17.00	17.00	17.00
50	5.51	9.17	11.88	14.23	15.71	17.00	17.00	17.00	17.00	17.00	17.00	17.00	17.00
55	5.48	9.16	11.79	14.17	15.62	17.00	17.00	17.00	17.00	17.00	17.00	17.00	17.00
60	5.43	9.11	11.33	13.40	14.00	16.38	17.00	17.00	17.00	17.00	17.00	17.00	17.00
65		8.42	10.86	12.67	13.36	15.45	16.34	16.93	17.00	17.00	17.00	17.00	17.00
70			8.97	10.47	12.11	13.27	13.80	14.12	17.00	17.00	15.85	17.00	17.00
75				10.56	10.93	13.11	13.63	14.10	15.56	16.62	15.14	16.61	17.00
80				10.64	9.74	12.59	13.09	13.55	13.72	14.65	14.43	15.83	
Power Input (kW)													
	Ambient Temperature (°C)												
Water outlet(°C)	-30	-25	-20	-15	-10	-7	-5	2	7	10	15	20	25
25	3.72	3.98	5.21	5.50	5.48	6.09	5.41	4.70	3.58	3.50	2.89	2.72	2.65
35	4.11	4.49	5.56	5.94	6.12	6.16	5.99	5.74	3.72	3.64	3.46	3.17	2.68
40	4.31	4.91	5.88	6.32	6.43	6.54	6.28	5.90	4.43	4.38	3.77	3.49	2.98
45	4.50	5.32	6.20	6.70	6.74	6.92	6.57	6.05	4.73	4.75	4.08	3.81	3.28
50	4.89	5.79	6.67	7.07	7.35	7.43	7.18	7.01	5.29	5.26	4.48	4.17	3.89
55	5.38	6.11	7.07	7.64	7.96	7.98	7.79	7.36	5.43	5.34	4.86	4.54	4.52
60	5.39	6.99	7.43	7.40	7.36	8.05	8.17	7.93	6.04	6.04	5.38	4.94	4.59
65		6.56	7.81	7.38	6.99	8.08	8.24	8.33	6.53	6.48	5.86	6.07	4.90
70			7.09	6.70	6.62	6.98	7.20	7.82	7.16	6.91	6.03	6.13	6.16
75				7.59	7.44	7.79	8.04	8.16	7.46	7.69	6.61	6.87	7.07
80				8.48	8.25	8.55	8.82	8.92	7.59	7.82	7.18	7.47	
COP(kw/kw)													
	Ambient Temperature (°C)												
Water outlet(°C)	-30	-25	-20	-15	-10	-7	-5	2	7	10	15	20	25
25	1.52	2.35	2.32	2.67	2.92	2.79	3.14	3.61	4.75	4.85	5.89	6.24	6.41
35	1.37	2.06	2.16	2.43	2.60	2.76	2.84	2.96	4.57	4.67	4.92	5.36	6.34
40	1.30	1.88	2.04	2.27	2.47	2.60	2.71	2.88	3.84	3.88	4.51	4.88	5.71
45	1.24	1.73	1.93	2.13	2.34	2.46	2.59	2.81	3.59	3.58	4.17	4.47	5.19
50	1.13	1.58	1.78	2.01	2.14	2.29	2.37	2.42	3.22	3.23	3.79	4.08	4.38
55	1.02	1.50	1.67	1.85	1.96	2.13	2.18	2.31	3.13	3.18	3.50	3.74	3.76
60	1.01	1.30	1.52	1.81	1.90	2.03	2.08	2.14	2.81	2.81	3.16	3.44	3.70
65		1.28	1.39	1.72	1.91	1.91	1.98	2.03	2.60	2.62	2.90	2.80	3.47
70			1.27	1.56	1.83	1.90	1.92	1.81	2.37	2.46	2.63	2.77	2.76
75				1.39	1.47	1.68	1.70	1.73	2.09	2.16	2.29	2.42	2.41
80				1.25	1.18	1.47	1.48	1.52	1.81	1.87	2.01	2.12	

Unpacking

1. Cut the straps around the outer packaging and carton.
2. Remove the outer packaging straps.
- 3-4 Slide the carton upwards.
5. Remove the honeycomb cardboard packing.
6. Inspect the unit for damage. Any damage or missing parts must be reported immediately.

Supplied Components

- 1 x User Manual
- 1 x User Display
- 1 x 4 core display extension
- 2 x NTC Temperature Sensors
- 1 x WiFi Module
- 4 x Antivibration rubber pads
- 2 x Condensate adaptors

Unit Dimensions

6kw/12kW

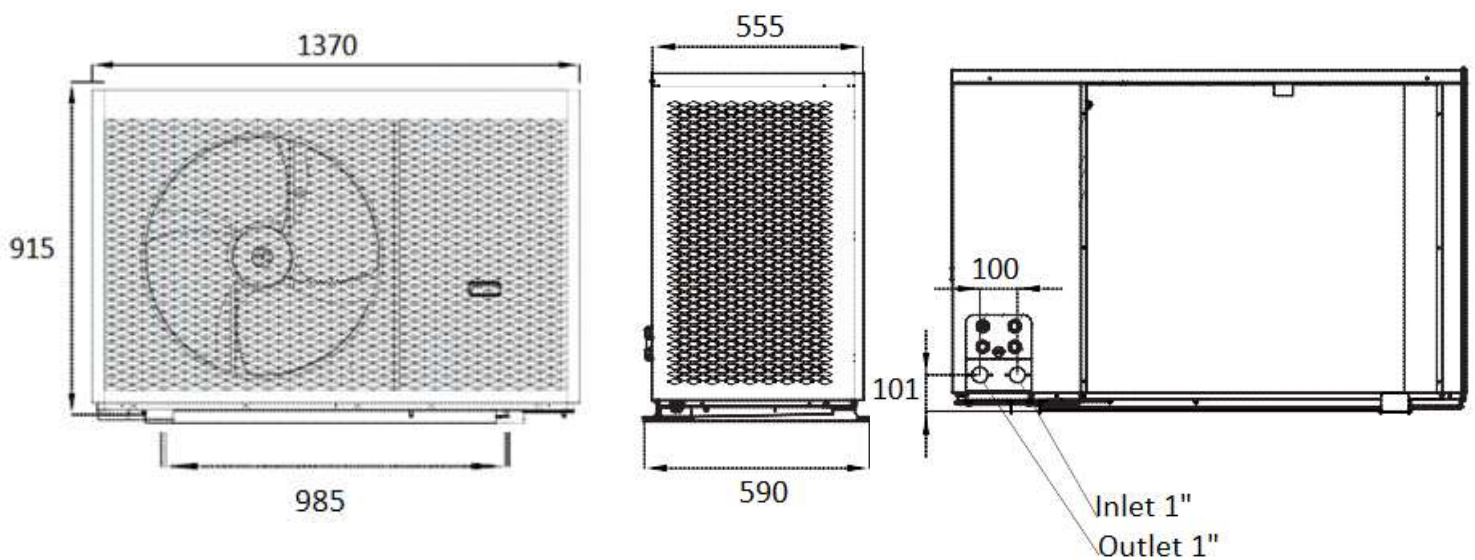

17kW

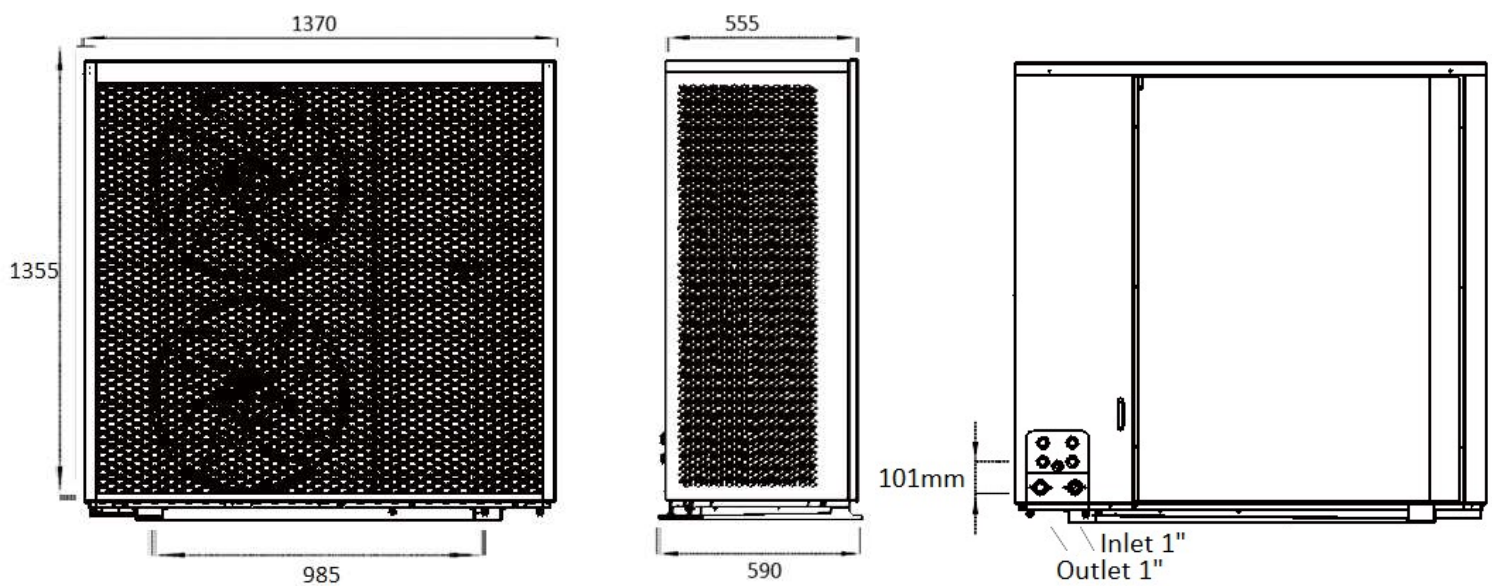

Installation Space and Clearances

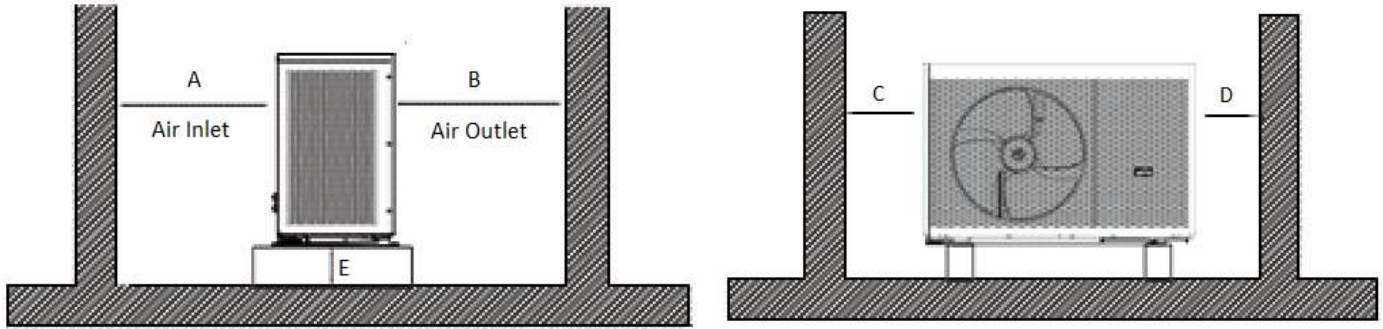

- A = 300mm**
- B = 1500mm**
- C = 1000mm**
- D = 500**
- E = 100**

Siting The Unit

When installing the outdoor unit, please refer to MCS Installation guidelines to select the appropriate Location.

1. The heat pump must not be sited inside the property.
2. The location must have good ventilation. Avoid siting under car ports or small enclosed courtyards.
3. The area should be free from heat radiation and open flames.
4. The location should be away from gas appliances, electric heaters and any other potential source of ignition.
5. Check the strength and level of the installation ground so that the unit will not cause any operating vibration or noise after installation.
6. Mount the Unit on the supplied Anti Vibration Pads using suitable fixings for the Ground Type. Alternatively, the unit can be mounted on purpose made heat pump support feet available separately.
7. Avoid recirculating the outlet air.
8. Install the unit with the suction side (Rear) facing the wall.
9. There must be enough space around the unit for maintenance.
10. Protect the unit from possible overhanging snowfall.
11. Avoid siting in areas subject to strong winds.
12. There must be sufficient space to carry the unit in and out of the site.
13. Operation noise is minimal, however, try to avoid areas close to bedroom windows.
14. Coastal areas have a higher risk of salt corrosion. Consider having the unit professionally treated to alleviate future corrosion issues.

Please refer to the installation dimensions of the unit for installation.

Unit Volume

6kw/12kw = 0.696m³

17kW = 1.030m³

Panel Removal

Service Panel

Remove the 2 screws at the locations shown in the figure below.
Slide the panel down to remove.



Top Panel

Remove the 2 screws at the locations shown in the figure below.
Slide the top panel towards the service panel and lift to remove.

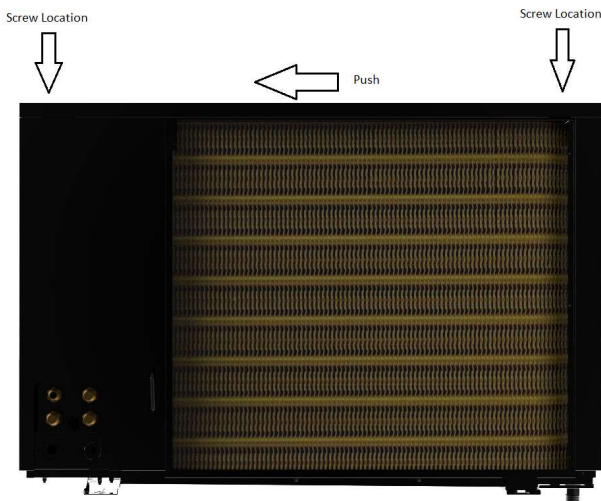

Electrical Wiring Diagram

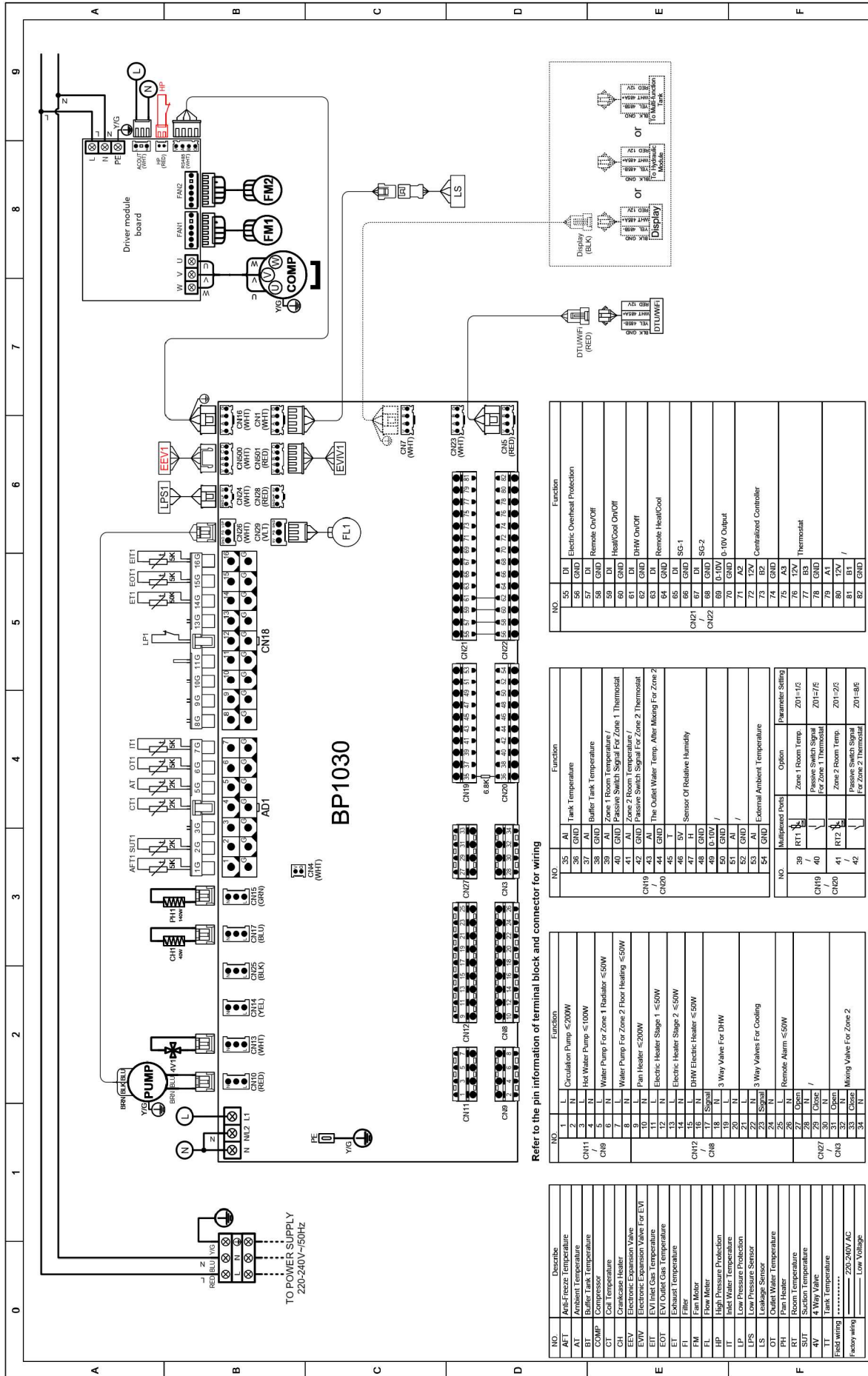

BP1030

Refer to the pin information of terminal block and connector for wiring

NO.	Function
1	L
2	N
3	N
4	N
5	N
6	N
7	N
8	N
9	N
10	N
11	L
12	L
13	L
14	N
15	L
16	N
17	Signal
18	N
19	L
20	N
21	N
22	Signal
23	Signal
24	N
25	N
26	N
27	Open
28	N
29	N
30	N
31	Open
32	N
33	N

NO.	Function
35	AI
36	GND
37	AI
38	AI
39	AI
40	GND
41	AI
42	AI
43	AI
44	GND
45	T
46	5V
47	H
48	GND
49	0-10V
50	GND
51	GND
52	GND
53	AI
54	GND

NO.	Function
55	DI
56	GND
57	DI
58	GND
59	DI
60	GND
61	DI
62	GND
63	DI
64	GND
65	DI
66	GND
67	DI
68	GND
69	0-10V
70	GND
71	A2
72	12V
73	B2
74	GND
75	A3
76	12V
77	B3
78	GND
79	A1
80	A1
81	B1
82	GND

NO.	Describe
AT	Air/Freeze Temperature
BT	Buffer Tank Temperature
COMP	Compressor
CT	Coil Temperature
CH	Crankcase Heater
EEV	Electronic Expansion Valve
EVI	Electronic Expansion Valve For EVI
EIT	EVI Inlet Gas Temperature
EOT	EVI Outlet Gas Temperature
EL	Evaporator Temperature
EM	Fan Motor
FL	Flow Meter
HP	High Pressure Protection
LP	Low Pressure Protection
IT	Inlet Water Temperature
LS	Leakage Sensor
LPS	Low Pressure Protection
OT	Outlet Water Temperature
PH	Pin Heater
RT	Room Temperature
SUT	Suction Temperature
AV	4-Way Valve
VT	Valve Temperature
Field wiring 220-240V AC
Factory wiring Low Voltage

Power Supply Connection

This should be terminated at a double pole isolator located in close proximity above the unit.
The power supply must be protected by a Type B RCD or RCBO.

Electrical Connections

NO.		Function	
CN11 / CN9	1	L	Circulation Pump ≤200W
	2	N	
	3	L	Hot Water Pump ≤100W
	4	N	
	5	L	Water Pump For Zone 1 Radiator ≤50W
	6	N	
	7	L	Water Pump For Zone 2 Floor Heating ≤50W
	8	N	
CN12 / CN8	9	L	Pan Heater ≤200W
	10	N	
	11	L	Electric Heater Stage 1 ≤50W
	12	N	
	13	L	Electric Heater Stage 2 ≤50W
	14	N	
	15	L	DHW Electric Heater ≤50W
	16	N	
	17	Signal	
	18	N	3 Way Valve For DHW
	19	L	
	20	N	
	21	L	
	22	N	3 Way Valves For Cooling
	23	Signal	
	24	N	
	25	L	Remote Alarm ≤50W
26	N		
CN27 / CN3	27	Open	
	28	N	
	29	Close	
	30	N	
	31	Open	
	32	N	
	33	Close	Mixing Valve For Zone 2
	34	N	

NO.		Function	
CN19 / CN20	35	AI	Tank Temperature
	36	GND	
	37	AI	Buffer Tank Temperature
	38	GND	
	39	AI	Zone 1 Room Temperature / Passive Switch Signal For Zone 1 Thermostat
	40	GND	
	41	AI	Zone 2 Room Temperature / Passive Switch Signal For Zone 2 Thermostat
	42	GND	
	43	AI	The Outlet Water Temp. After Mixing For Zone 2
	44	GND	
	45	T	
	46	5V	Sensor Of Relative Humidity
	47	H	
	48	GND	
49	0-10V		
50	GND	/	
51	AI	/	
52	GND	/	
53	AI	External Ambient Temperature	
54	GND		

NO.	Multiplexed Ports	Option	Parameter Setting
CN19 / CN20	39	RT1	Zone 1 Room Temp. Z01=1/3
	40		Passive Switch Signal For Zone 1 Thermostat Z01=7/9
	41	RT2	Zone 2 Room Temp. Z01=2/3
	42		Passive Switch Signal For Zone 2 Thermostat Z01=8/9

NO.		Function	
CN21 / CN22	55	DI	Electric Overheat Protection
	56	GND	
	57	DI	Remote On/Off
	58	GND	
	59	DI	Heat/Cool On/Off
	60	GND	
	61	DI	DHW On/Off
	62	GND	
	63	DI	Remote Heat/Cool
	64	GND	
	65	DI	SG-1
	66	GND	
	67	DI	SG-2
	68	GND	
	69	0-10V	0-10V Output
	70	GND	
	71	A2	
	72	12V	Centralized Controller
	73	B2	
	74	GND	
	75	A3	
	76	12V	Thermostat
77	B3		
78	GND		
79	A1		
80	12V	/	
81	B1		
82	GND		

Terminals CN19 – CN22 are **VOLT FREE**.

57 & 58 should be linked.

59 & 60 should be connected to volt free heating controls.

61 & 62 should be connected to a volt free timer for domestic hot water control.

63 & 64 should be linked if external controls are being used.

3 Port Diverter valve.

17 – Switched Live

18 – Neutral

19 – Permanent Live

Temperature Sensors

The unit comes supplied with two NTC type temperature sensors for the Hot water Cylinder and Buffer Tank Sensor cables can be extended up to a maximum of 50m.

35 & 36 - TT = DHW Cylinder

37 & 38 - BT = Buffer Tank/Room Temperature

The Domestic hot water sensor should be routed to the cylinder and located inside a dry pocket.

Heat transfer paste must be used to ensure the sensor has optimal contact with the wall of the dry pocket. Failure to use heat transfer paste can lead to incorrect domestic hot water temperature readings.

The heating sensor can be used if the system incorporates a buffer tank or can be used for sensing room temperature. The sensor should be routed to the buffer and located inside a dry pocket. Heat transfer paste must be used.

When not using a buffer, the sensor should be left connected and stored at the top of the unit. On commissioning, operating parameters can be changed to allow for the specific use of the sensor.

Sensor cables should not run alongside or be part of 230v cabling. This will result in incorrect and unstable temperature readings.

User Interface Connection

The Heat pump is supplied with a Digital user interface and extension cable.

The interface should be mounted inside the property in an accessible position.

The extension cable should be terminated inside the heat pump at the white four pin terminal CN7, as per the diagram below.

The user interface cable can be extended up to a maximum of 30m using a similar sized cable.

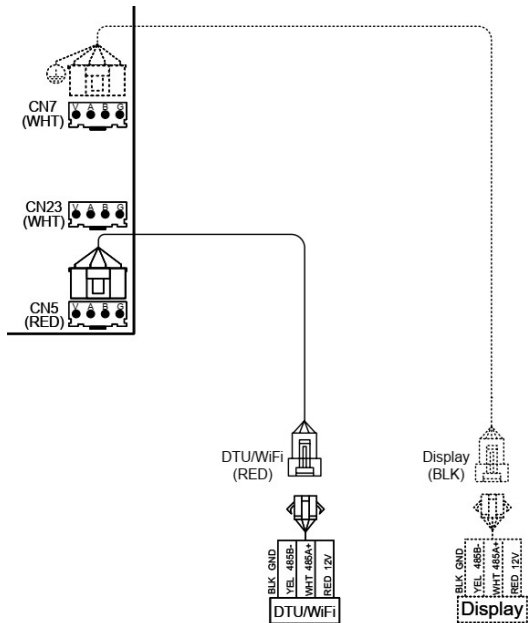

Data Transfer Unit (DTU)

The Heat pump is supplied with a data transfer unit that should be mounted on the outside casing of the heat pump using the inbuilt magnet. The aerial should be mounted as high as possible using the self-adhesive pad.

The cable should be routed through the appropriate cable gland and terminated at the red four pin terminal CN5.

System Requirements

All systems should have the relevant system components, e.g., Isolation valves, system filter, strainer, drain cock, expansion vessel, air vents and comply with the following British Standards.

It is the installers responsibility to ensure the installation complies with the relevant standards.

BS EN 12828 – Heating systems in buildings: Design for water-based heating systems.

BS EN 12831 – Heating systems in buildings: Method for calculation of the design heat load.

BS EN 14336 – Heating systems in buildings: Installation and commissioning of water-based heating systems.

BS7671 – Requirements for electrical installations. IEE wiring Regulations. Seventeenth Edition.

BS EN 7593 – Code of practice for treatment of water in heating systems.

The Building Regulations: Part 'L' (Northern Ireland)

Current I.E.E. Regulations

Local water undertaking By-laws.

System

Relevant Heating and Hot water controls will be required to complete the system dependant on system type.

All Pipe work should be flushed before connecting the heat pump.

All air should be removed from the system. Air vents should be installed at all high points in the system.

All pipework must be insulated to MCS standards.

The system should be treated with suitable inhibitor and antifreeze or antifreeze valves.

Isolation Valves

Full bore Isolation valves must be fitted on both the flow and return pipe work.

Warranty work will not be undertaken if not fitted.

Pressure Gauge

A pressure gauge must be permanently fitted in the system covering a range from 0 to 4 bar. Position where it can be seen when filling the system.

System Makeup

Provision can be made by pre-pressurisation of the system via a temporary hose connection and through a double check valve (non-return) and stop valve.

There must be no permanent connection to the mains water valve supply even through a non-return valve.

Drain Tapping

A drain tapping must be provided at the lowest point of the system, which will allow the entire system to be drained.

In-Line Filter/Strainer

An in-line strainer and Magnetic type system filter must be fitted on the return pipework close to the heat pump.

Condensate

The condensate can be routed to a sewer, soakaway, or condensate pump.

Any discharge should not be allowed to freeze.

Care should be taken when utilising a soakaway, condensate should discharge onto a gravel bed at least 900mm below the ground level to avoid freezing. The condensate pipe work should run vertically, directly below the heat pump, sleeved with 100mm pipe.

Any condensate pipework that runs either vertically or horizontally should be protected from freezing. This might include the use of electrical trace heating.

Expansions Vessel Capacity

The expansion vessel should be a diaphragm type expansion vessel, conforming to the current issue of BS 4814. The expansion vessel must be connected to the system at a point close to the inlet side of the circulating pump. The expansion vessel volume depends on the total water system volume and the initial system design pressure. For any system an accurate calculation of vessel size is given in the current issue of BS 5449 and BS 7074 Part 1.

Note: A higher initial design pressure requires a larger Volume expansion vessel.

The charge pressure must not be less than the static head of the system that is the highest point of the system above the expansion vessel.

The maximum running temperature of the system is 80°C. It is recommended that this figure be used in the calculations of vessel size.

Where design information is not complete the following chart can be used for selecting the size of the vessel.

Safety valve setting (bar gauge)	3 bar		
Vessel charge and initial system pressure (bar gauge)	0.5	1.0	1.5
Total water content of system	Vessel volume		
Litre	Litre	Litre	Litre
25	2.3	3.3	5.9
50	4.4	6.7	11.8
75	7.0	10.0	17.7
100	9.4	13.4	23.7
125	11.7	16.7	29.6
150	14.1	20.1	35.5
175	16.4	23.4	41.4
200	18.8	26.8	47.4

Safety Valve

A safety valve set at 3 bar should be fitted with the drain routed to the outside of the building. The drain must not discharge above an entrance or a window or any public access area, be clear of any electrical fittings and positioned so that any discharge can be seen.

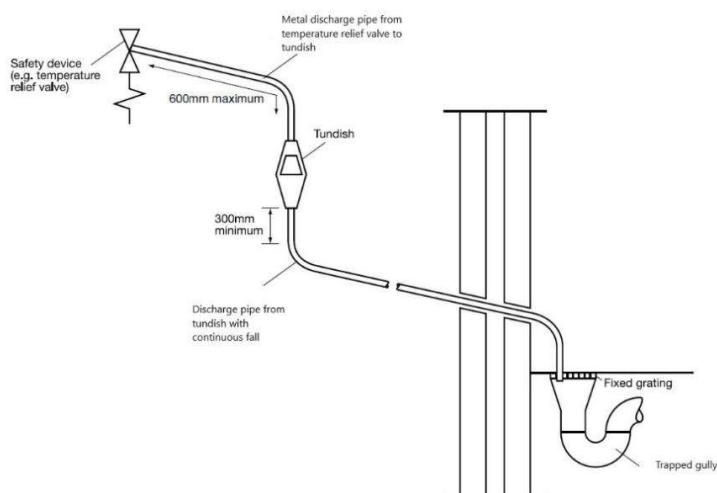

System Schematics

Volumiser and Hot Water Cylinder

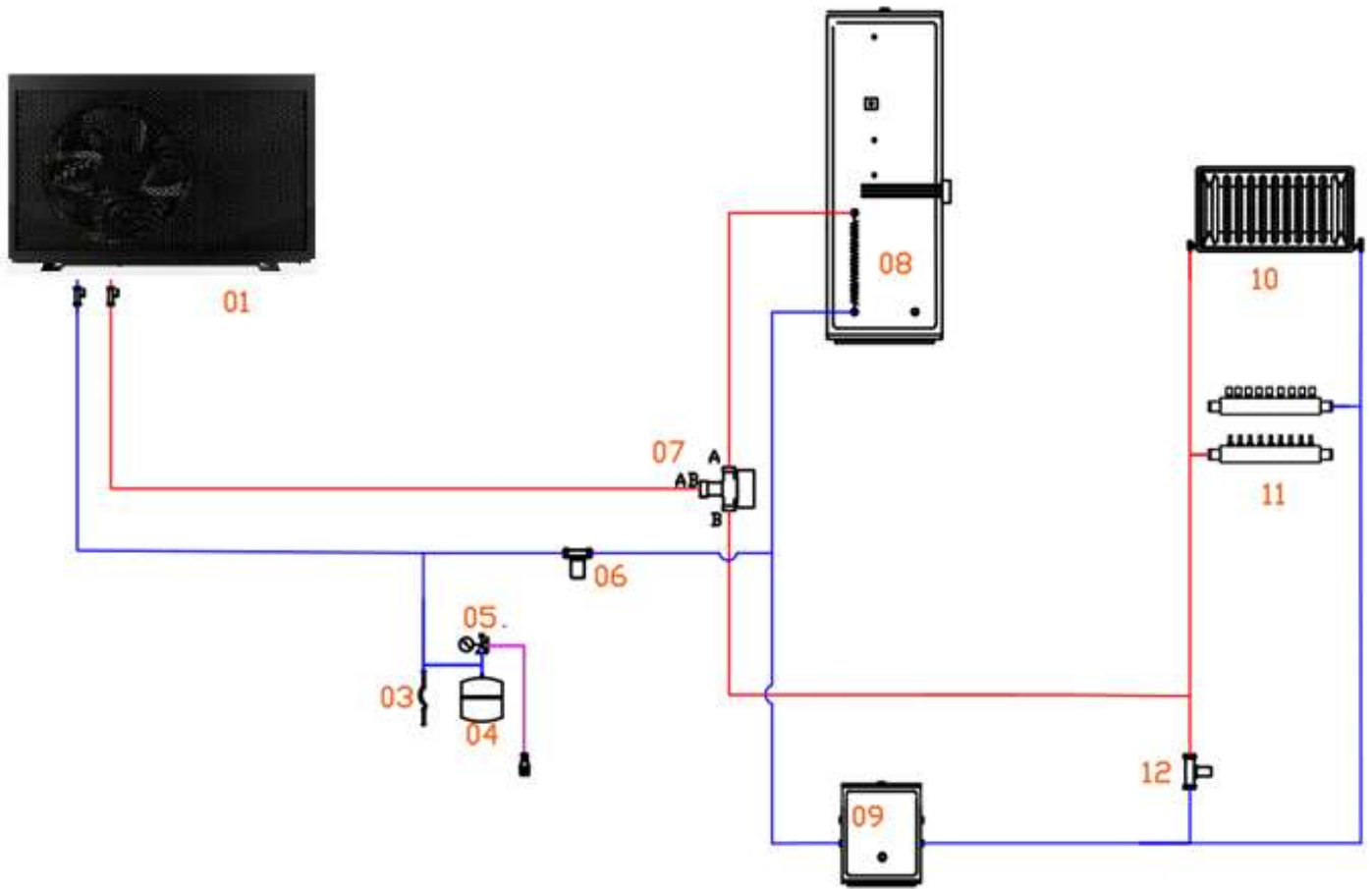

01 – Heat Pump

04 – Expansion Vessel

07 – Diverter Valve

10 – Zone 1

02 – Isolation Valves

05 – Pressure Gauge

08 – DHW Cylinder

11 – Zone 2

03 – Filling Loop

06 – Magnetic Filter

09 – Volumiser

12 – Auto Bypass Valve

Buffer and Hot Water Cylinder

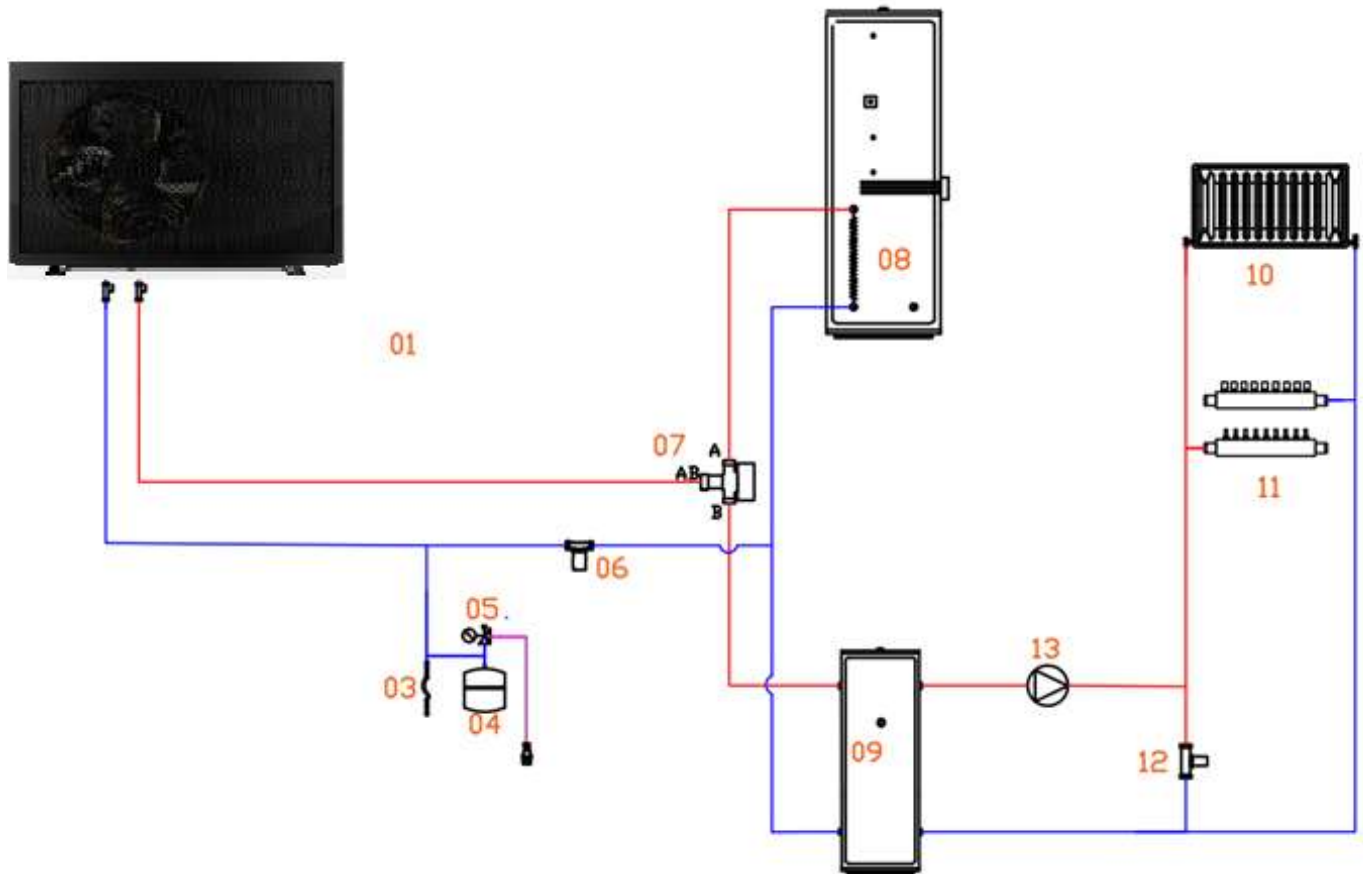

01 – Heat Pump

04 – Expansion Vessel

07 – Diverter Valve

10 – Zone 1

13 – External Pump

02 – Isolation Valves

05 – Pressure Gauge

08 – DHW Cylinder

11 – Zone 2

03 – Filling Loop

06 – Magnetic Filter

09 – Buffer Tank

12 – Auto Bypass Valve

Volumiser Heat Only

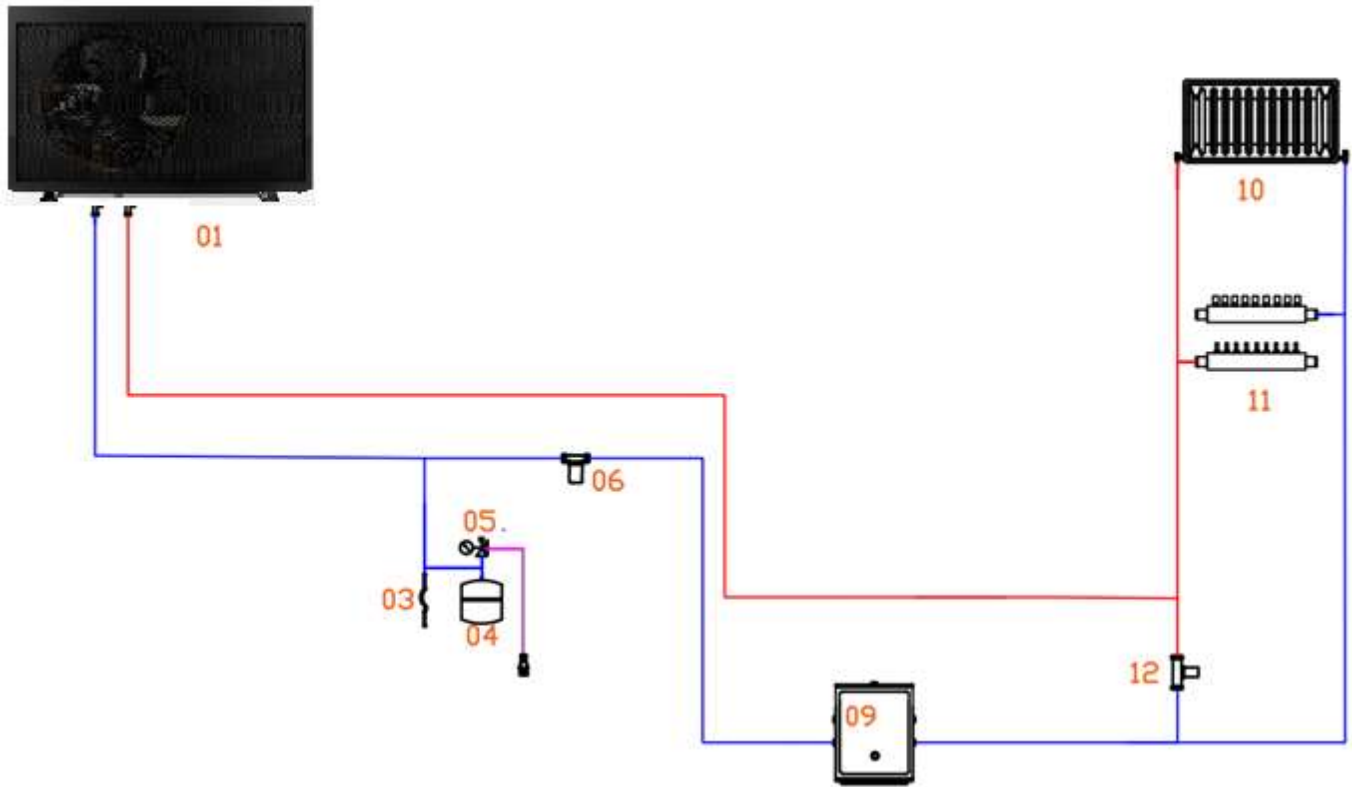

01 – Heat Pump

04 – Expansion Vessel

07

10 – Zone 1

02 – Isolation Valves

05 – Pressure Gauge

08

11 – Zone 2

03 – Filling Loop

06 – Magnetic Filter

09 – Volumiser

12 – Auto Bypass Valve

Hot Water Only

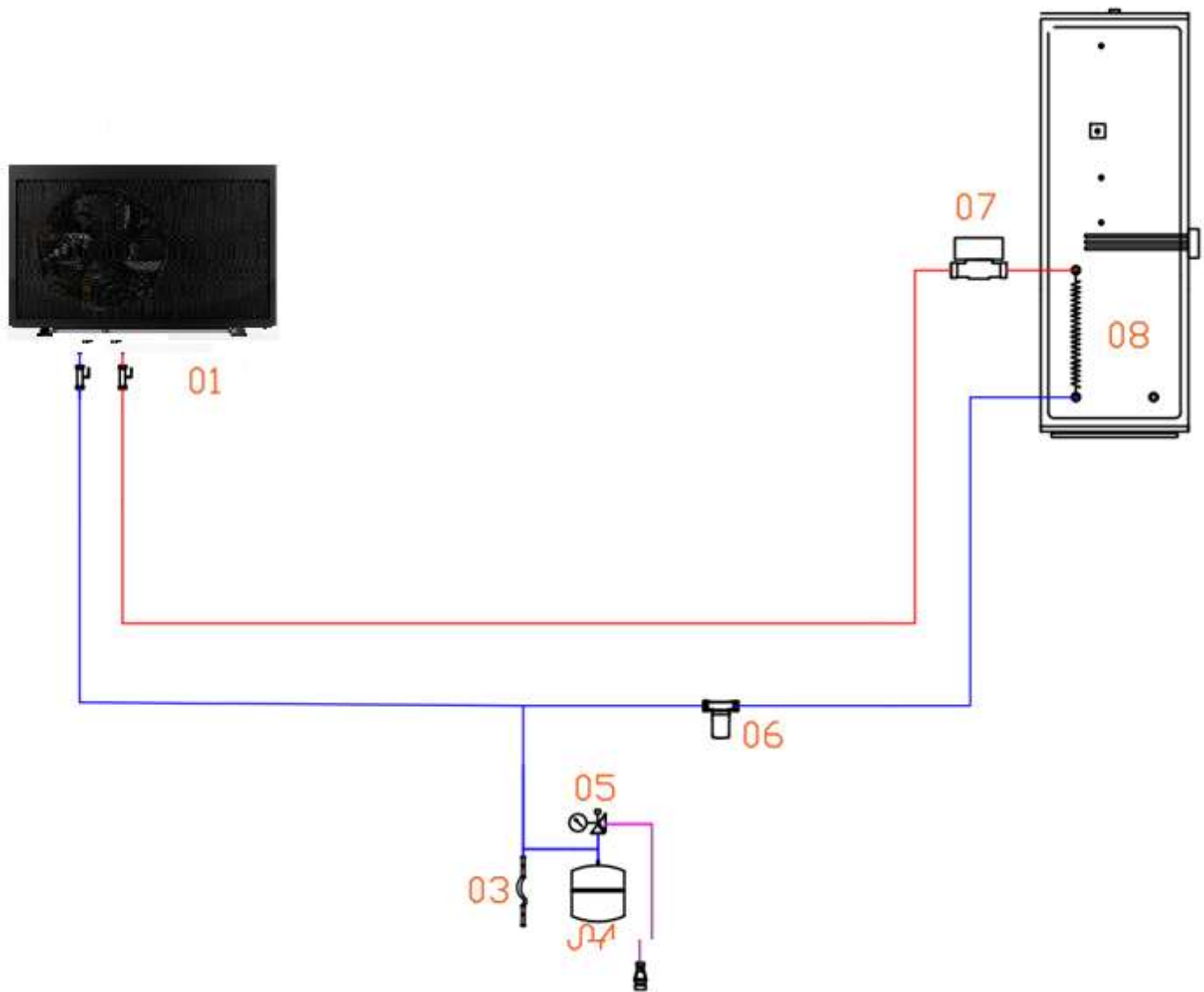

01 – Heat pump

04 – Expansion Vessel

07 – Zone Valve

02 – Isolation Valves

05 – Pressure Gauge

08 – Hot Water Cylinder

03 – Filling Loop

06 – Magnetic Filter

All schematics are supplied for information and general guidance only. No responsibility is accepted for any errors or omissions contained within or for any cost incurred in rectifying any work relating to it. Drain off points and AAV's to be fitted where appropriate, all applicable laws and regulations must be followed.

Existing heating distribution pipework and emitters must be power flushed before the heat pump and ancillaries are connected to the system.

Inspection Before Operation

Check all pipework and Electrical connections are correct.

Make sure the system is full of water, all relevant valves are open, and the system shows no signs of leaks.

Ensure all air has been vented from the system and the system pressure is correct.

Check the supply voltage is correct and the unit is earthed.

Review the control interface and see if there are any fault codes indicated. Reference the Fault Code list for information regarding any code shown on the display.

Make sure the sensor(s) are located in the Buffer Tank and Hot Water Cylinder depending on system configuration.

Drain Outlet

Install the unit onto the mounting base.

Insert the drain outlets (supplied) into the drain outlet holes on the base tray and pus up until it clicks into place.

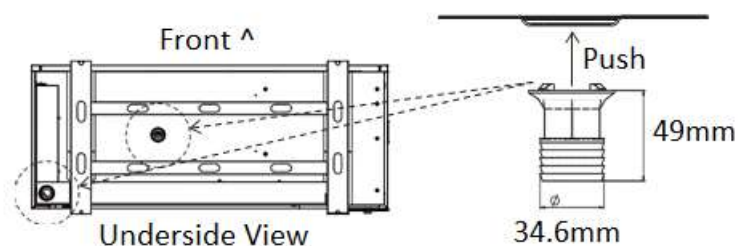

Internal Automatic air vent

Ensure the auto air vent cap is loose prior to filling the system to facilitate the removal of air form the heat pump.

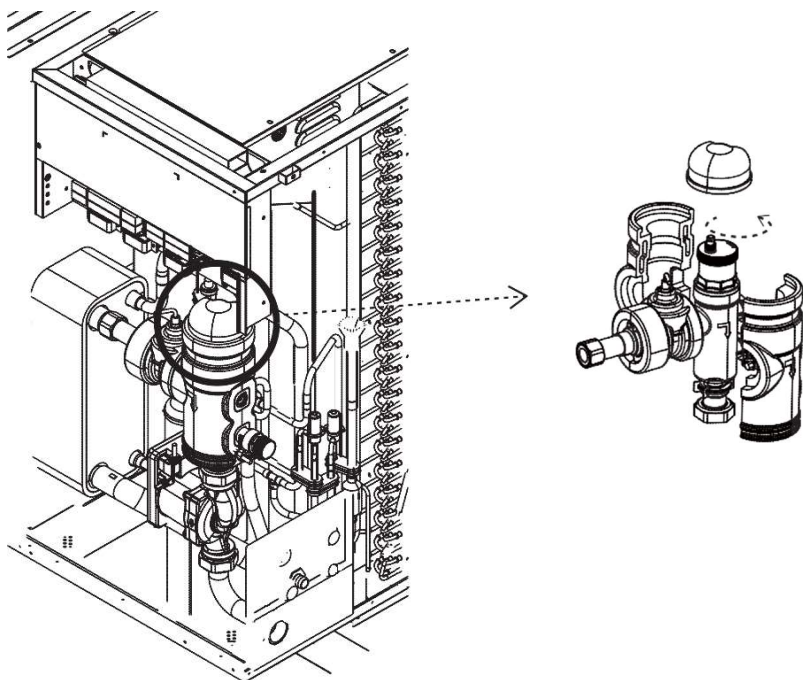

Commissioning the Heat Pump

Please complete the Commissioning form on pages 43 & 44 of this manual.

The control interface should now be set up, set the time, date, and any timer requirements. Follow the User Interface guide on page 27

Parameters should be set for different types of installs via the user interface using passcode 22. Parameters should only be changed by qualified installers. Changing parameters without professional guidance can severely affect the efficiency and safe operation of the heat pump, and doing so may also impact your appliance warranty.

Alternatively contact Trianco Technical support for assistance. 01142572300 Please quote the heat pump serial number.

Typical Parameters

System Settings

H07	Control Mode
0	User Interface
1	3 rd Party Controls

H25	Temperature Control Selection
0	Outlet water Temperature
1	Room Temperature
2	Buffer Tank Temperature
3	Inlet Water Temperature

H40	External Pump Selection
0	Hot water
1	Warm Water Circulation
2	Off When Defrosting
3	Heating

Hot Water Disinfection Settings

Parameter Name	Parameter Code	Parameter Value to be set
Disinfection Water Temperature	G01	60°C
Time Duration of Disinfection	G02	60 minutes
Disinfection Start Time	G03	0 – 23h
Interval Period of Disinfection	G04	7 Days
Enable Disinfection	G05	0=NO, 1=Yes

Select the operation mode by pressing the Mode key on the control interface.

Heating – Select for controlling the temperature of the heating.

Hot Water + Heating – Select this mode only if the system is installed to allow the heat pump to control the DHW and 3 port diverter valve.

Set the target temperature.

Depending on the system configuration, you can select separate target temperatures for the Hot Water and Heating.

Start the heat pump by pressing the power symbol on the Control interface.

If third party controls are connected to the heat pump insure there is a demand.

The internal water pump will run for approximately 1 minute followed by the fan, the compressor will then start. Observe the unit running, check the outlet pipework for temperature increase. Allow the heat pump to fully heat the buffer tank or system (if connected direct) to the set temperature.

Important

While the heat pump is working make sure the flow rate is correct. Flow rate data can be found on the heat pumps data label.

Swipe from left to right to show the status screen which will indicate actual flow rate. Insufficient flow rate will cause system issues, poor performance and poor efficiency. Minimum stated flow rates must be observed.

App Control

The unit is supplied with a pre-installed Data Transfer Unit (DTU) to allow control of the High Temperature Heat pump via the Warm Link App. Scan the QR code to download the app.



Download from the Google Play store for Android devices or Apple App Store for iOS devices. Please see the separate in App user instructions for guidance on set up and operation.

Note: Data connection and DTU set up may take up to 15 minutes. Once connection has been made, Trianco will be able to see the unit on-line via the IoT platform. Trianco will be able to monitor and adjust settings if requested. This may become useful at the commissioning stage of the install.

User Interface Operation Guide

Main Interface Display and Function

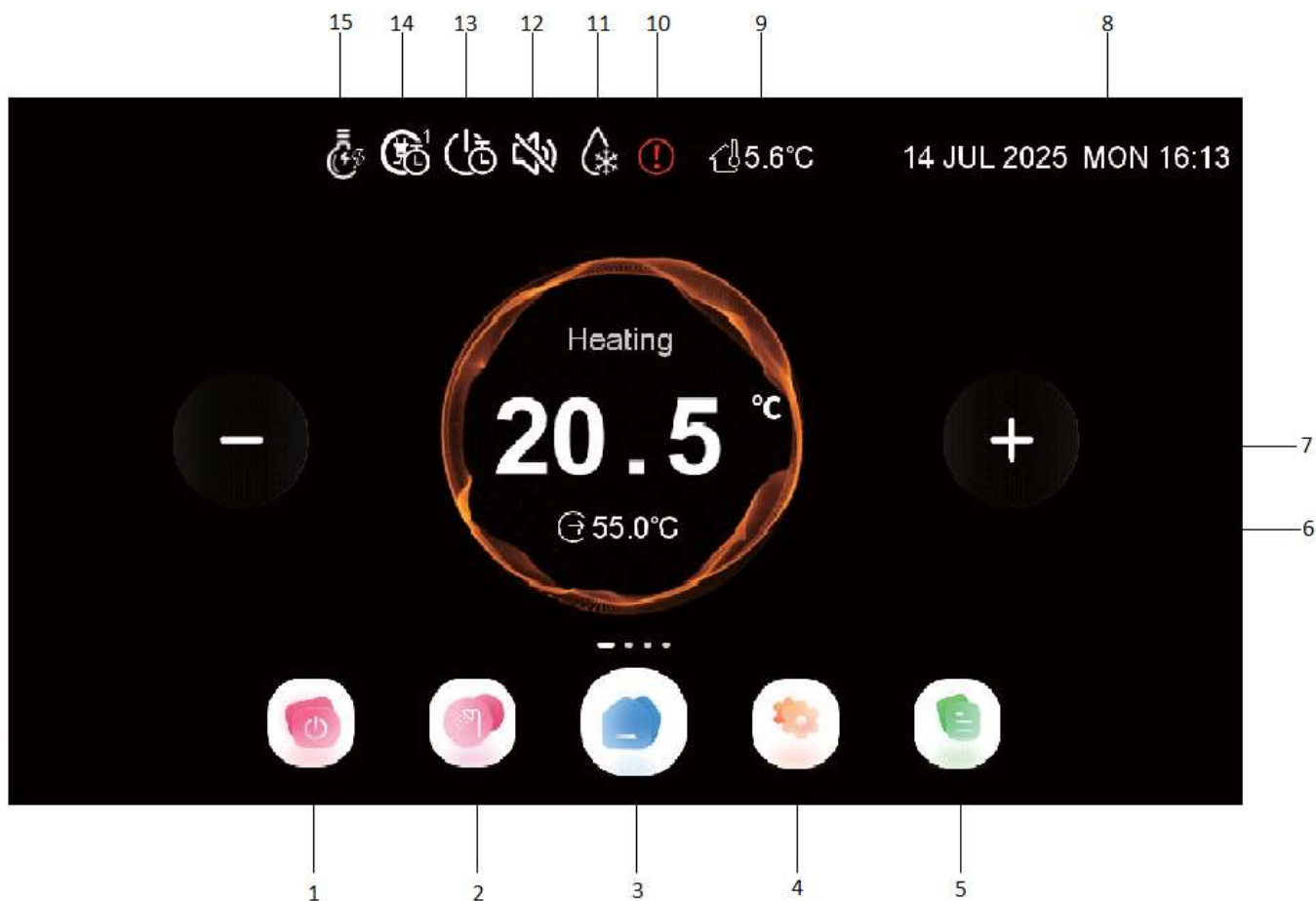

Main Key Functions

- | | |
|------------------------|---|
| 1. On/Off | Click this key to switch ON or OFF |
| 2. Mode | Used to select the operation modes. Heating, DHW, Heating + Hot Water |
| 3. Main | Return to Main Interface |
| 4. Setting | Used to select the Settings interface |
| 5. User Interface | Used to select the User interface |
| 6. Current Temp | Display current temperature depending on source chosen, Buffer, inlet etc |
| 7. Target Temperature | Displays current mode Target temperature (Adjustable) |
| 8. Time and Date | |
| 9. Outdoor Temperature | |
| 10. Fault Icon | Flashes when an error has occurred |
| 11. Defrost | Only visible when the unit is in defrost mode |
| 12. Silent Mode | Displays when silent mode is activated |
| 13. Power timer | Displays when the power timer is activated |
| 14. Schedule | Displays when the scheduled timer is activated |
| 15. SG Ready | Displays current SG Mode |

Mode

Five modes can be selected.

Click the mode button and select between Hot water only, Heating only, Cooling only, Heating and Hot water, Cooling and hot water.

Note the cooling function will only work if the system has been designed to cool. Do not select cooling without consulting the installer.

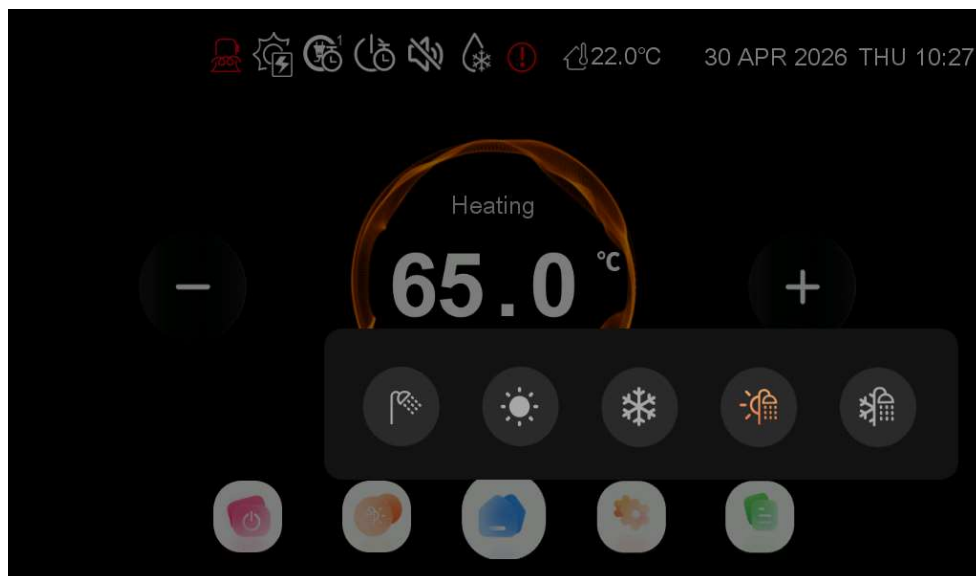

Function Setting

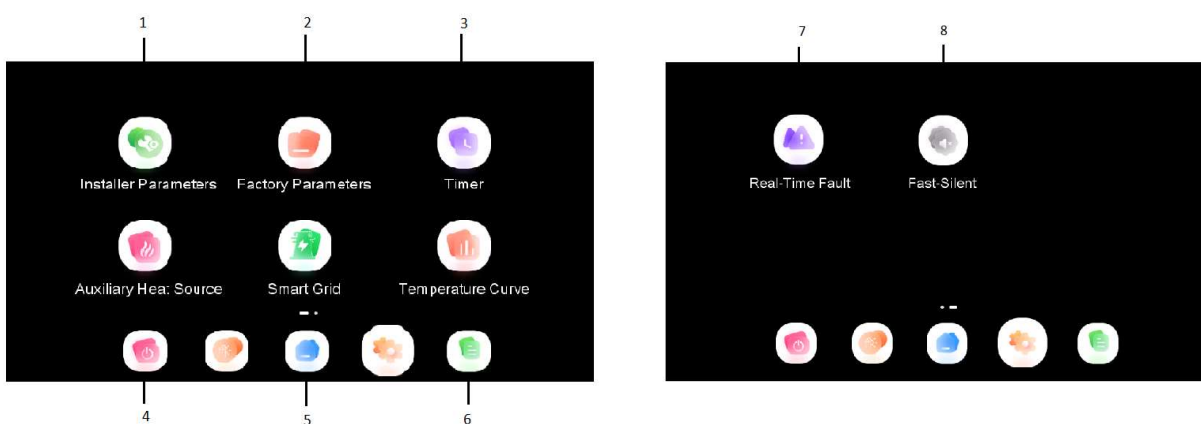

No.	Name	Description of operation
1	Installer Parameters	The interface is for installers
2	Factory Parameters	Click the key and enter the password to enter the factory parameter settings and status parameters
3	Timer	Click to enter the Timer setting interface
4	Auxiliary Heat Source	Click to enter the auxiliary heat function interface
5	Smart Grid	Click to enter the SG function interface
6	Temperature Curve	Click to the temp. curve interface
7	Fault	Click to view the fault interface
8	Fast-Silent	Click to mute

Timer Function

Click the Timer button in the setting interface to enter the timer function interface

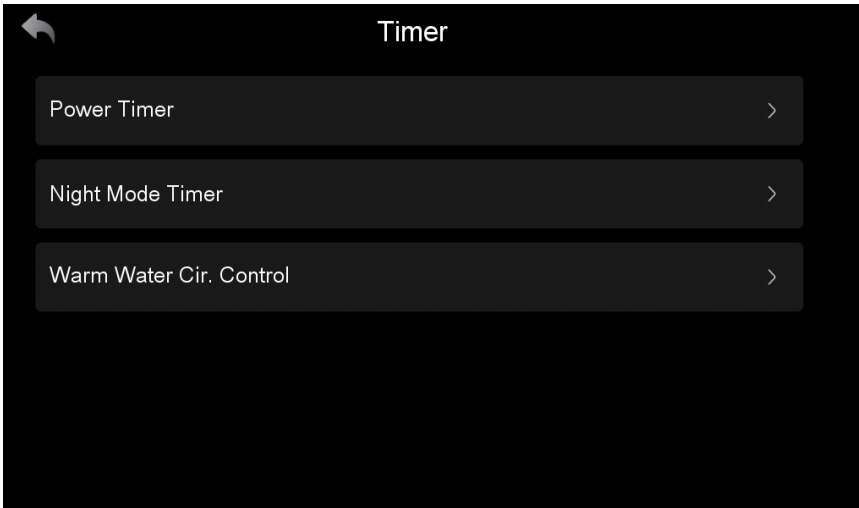

Power Timer Function

Used to Power on/off the heat pump. 6 separate timers can be selected along with choice of days of the week.

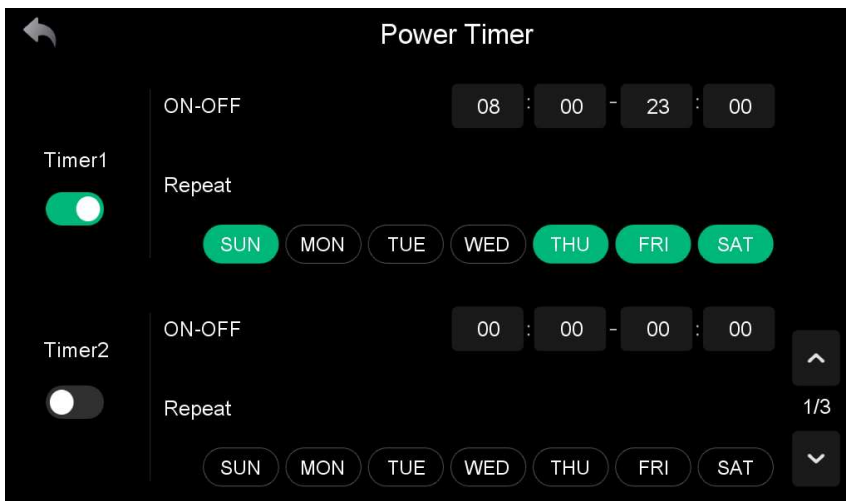

Silent Timer Function

The silent feature minimises noise levels by limiting compressor and fan speeds.

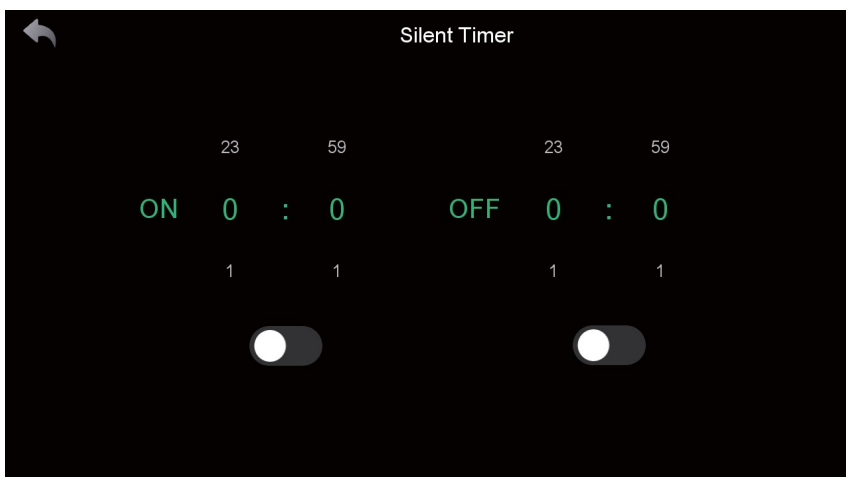

Warm Water Circulation Control

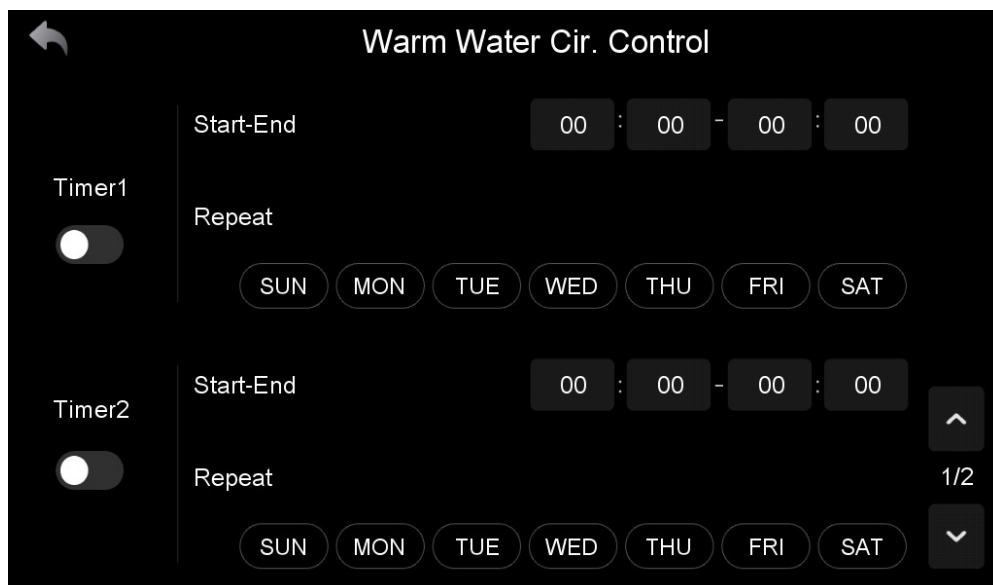

Auxiliary Heat Function

Click the auxiliary heat function button in the setting interface to enter the auxiliary heat function interface.

Current Status displays three electrical heating on/off states and manual electric heating control parameters

Brief description displays the current AT temp and description of the conditions which the auxiliary heat source is turned on.

To use the electric heater function, press the parameters key, enter the code 22 and set the relevant parameters.

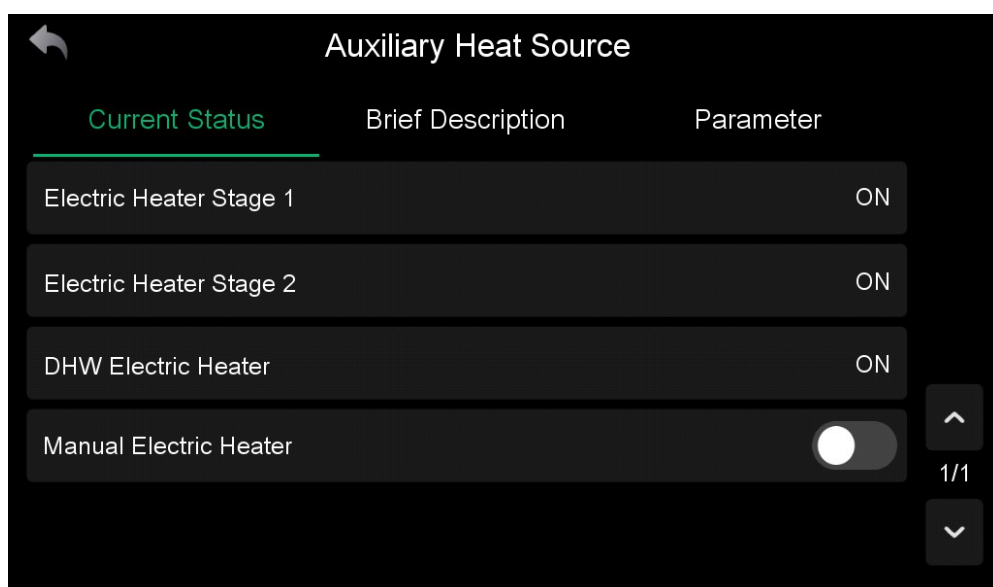

Temperature Recording

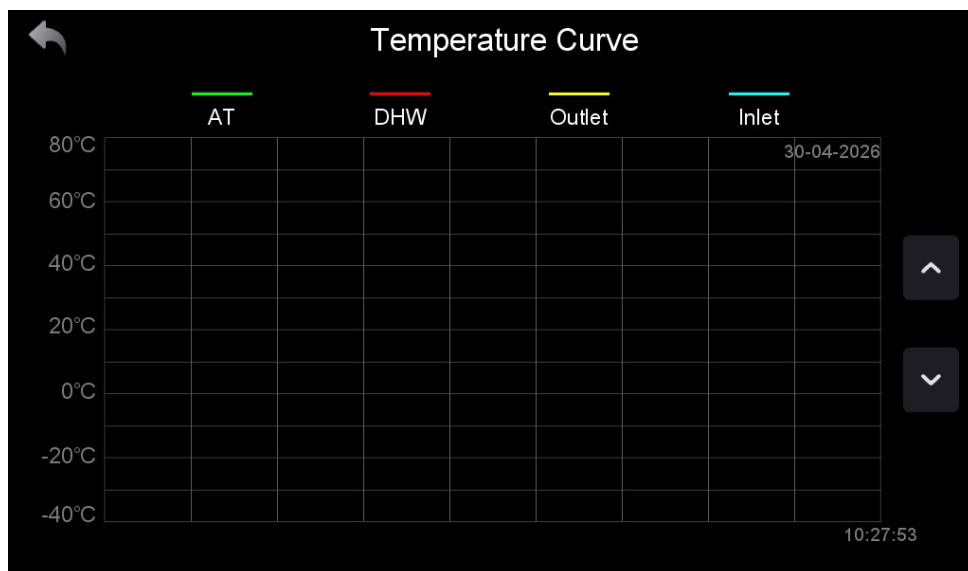

Smart Grid Function

Click the  button in the setting interface to enter the SG function interface.

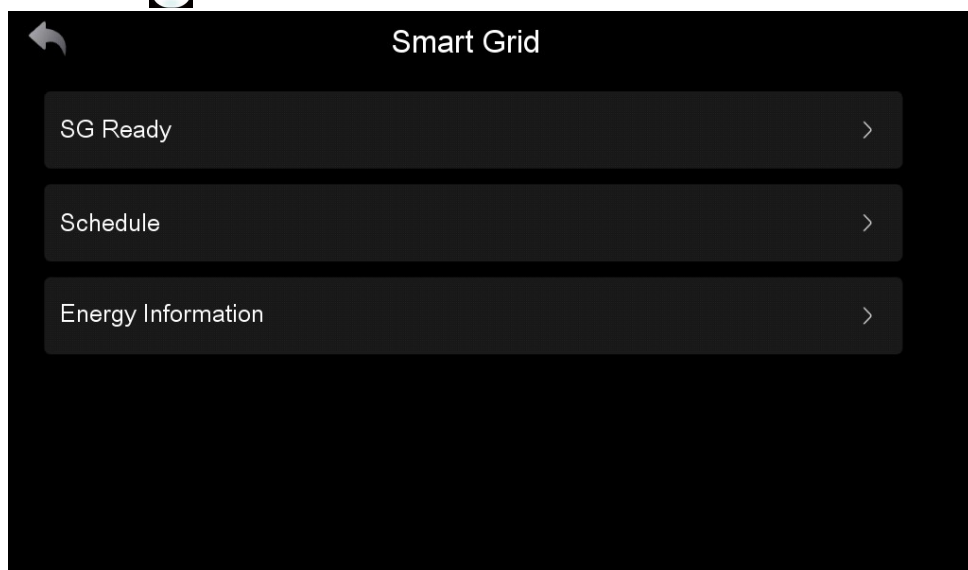

Through one or two contacts, the device receives information on available energy (from the PV system or the electricity supplier) and selects one of the 5 modes based on this information:

- Mode 1: Hibernation, where the heat pump is forced into standby. Standard mode is entered when continuous SG02 is in demand;
- Mode 2: Low energy mode with a maximum operating power of SG03 (when energy is insufficient or too expensive)
- Mode 3: Energy saving mode with maximum operating power SG04;
- Mode 4: Temperature Increasing Cooling/Heat Storage Mode. The heat pump target temp is raised according to SG05/SG06/SG07 and the electric heating is switched on according to SG08. (When energy consumption is low, the appliance can select a higher temp target to speed up heating and provide more domestic hot water);
- Normal Mode: Unit operates normally without power limitations and electric heater.

- To use the SG Ready function, press the "Parameters" key, enter the code "22" and select the number of contacts to be used (1 or 2) in the SG01 parameter.
- The 1st contact (SG-1) is defined as Remote On/Off; the 2nd contact (SG-2) is defined as Remote Heating/Cooling Switch.

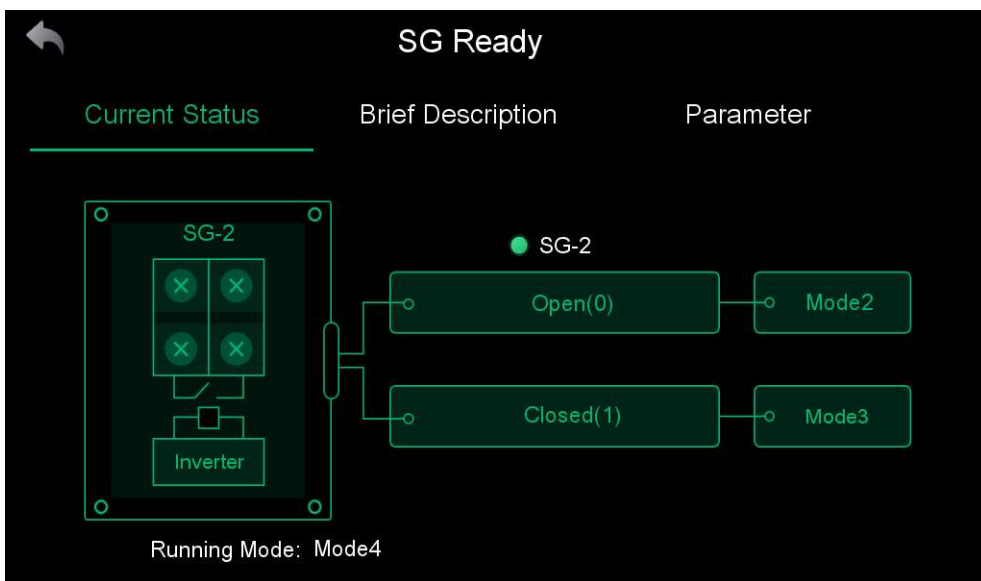
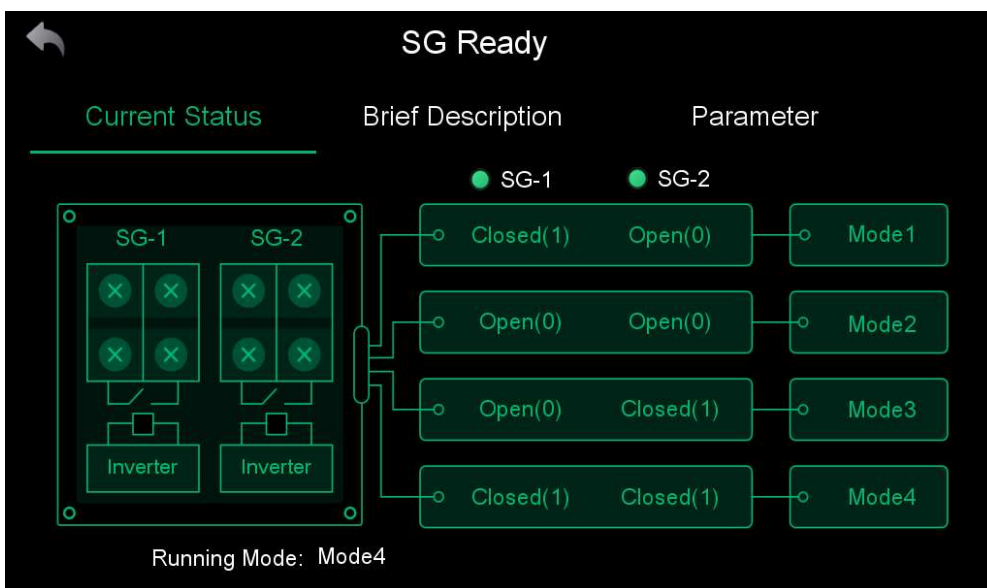
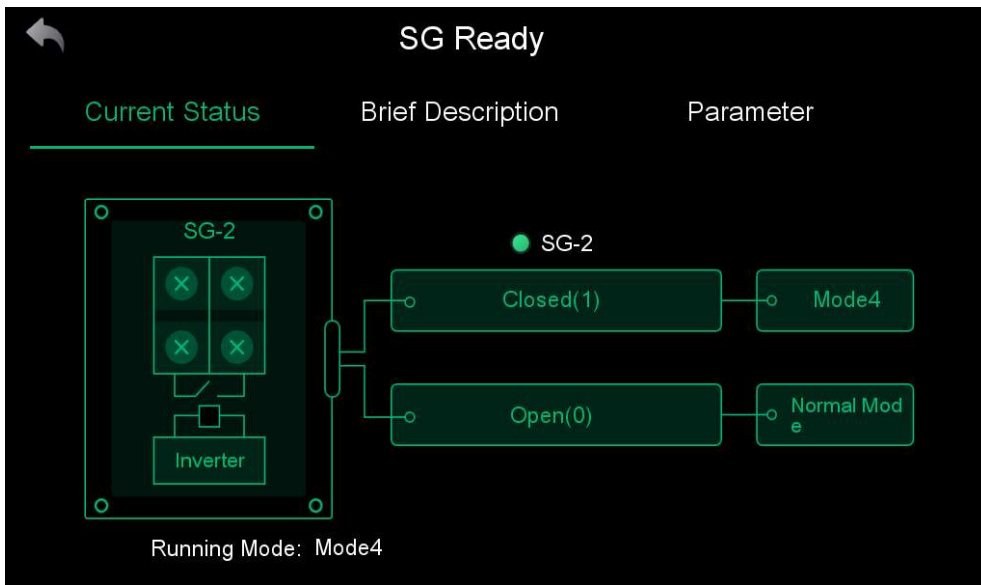

Schedule Function

Click the Smart Grid button and select Schedule to enter the schedule function interface.

6 different timers are supported

Set the following.

Start and End Time

Run Mode

Target Temperature

Maximum power consumption

Chosen days for Timer to run.

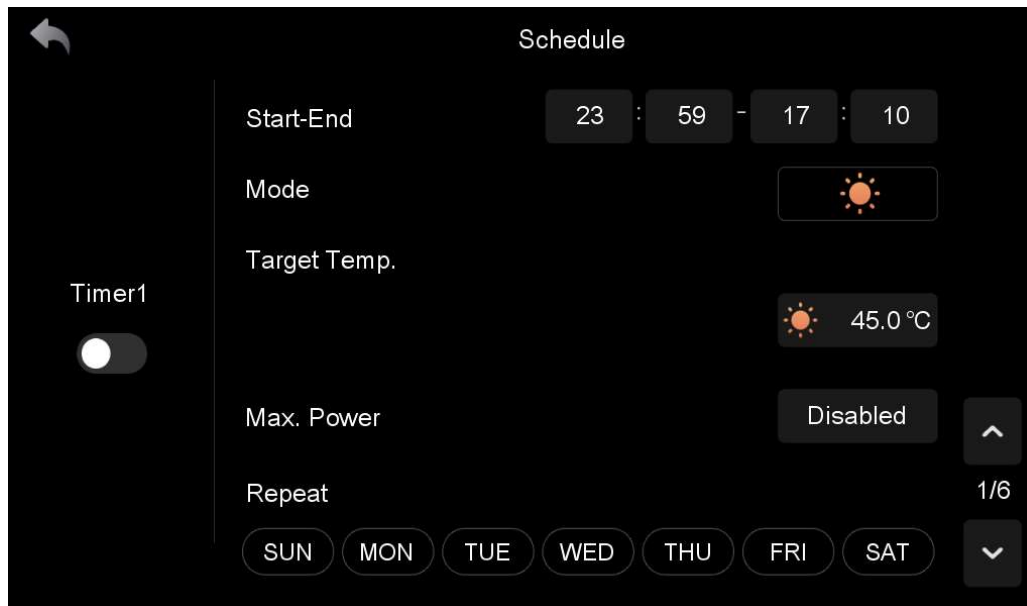

Fault Interface

Click the fault button in the setting interface to enter the fault interface.

If the fault has automatically recovered it is no longer displayed.

To clear faults, from the home screen click on the Installer setting, input the code 22, press OK, under fault history press the bin icon, enter the 2-digit date of the month and click OK

Detailed information on the faults and solutions can be found in the fault table.



Unit State Function

Click the Unit state button in the main interface to enter the customer function configuration menu.

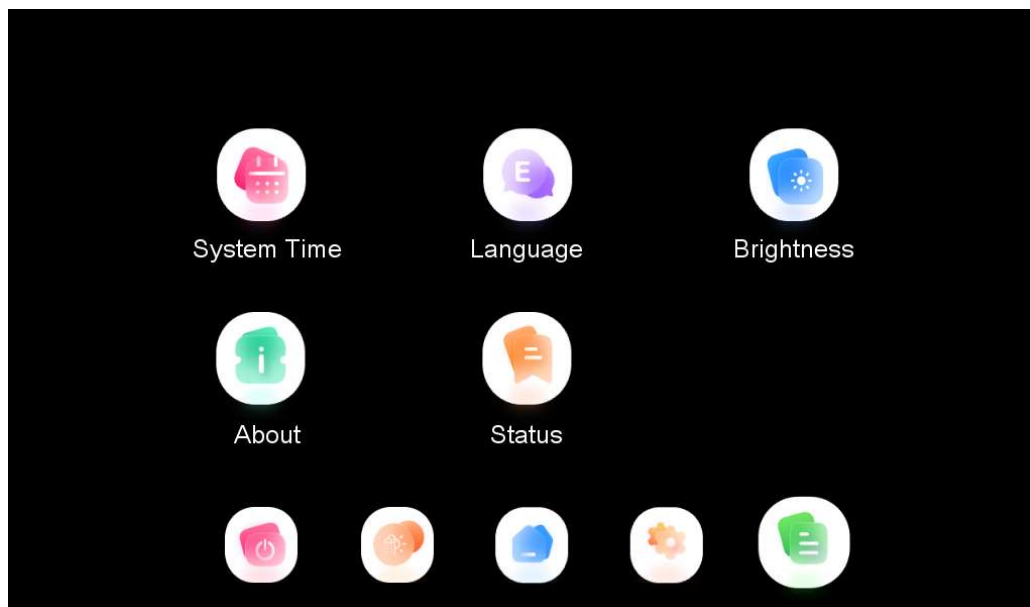

Name	Description of operation
System Time	Click to set the system time
Language	Click to change the language
Brightness	Click to adjust screen brightness
About	Display information about the device software
State	Turn the page to view all status parameters. Parameters are grouped by label according to the first letter of their code

Screen Brightness

Press the Brightness button (4) in the System settings Menu.

Use the slide bar to adjust the screen brightness.

Press the back key to return to the System setting Menu.

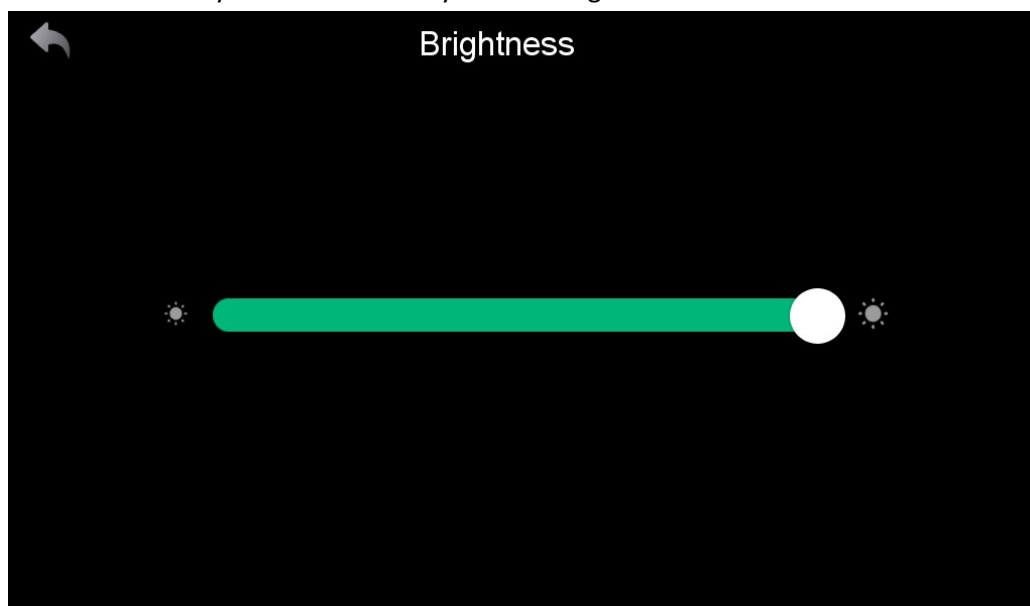

Weather Compensation

From the Home screen Click the settings Icon. Select the Installer setting. Input the Password 022 and press OK Adjust the Offset and Slope to your desired parameters. To Return to the Home screen press the back button.

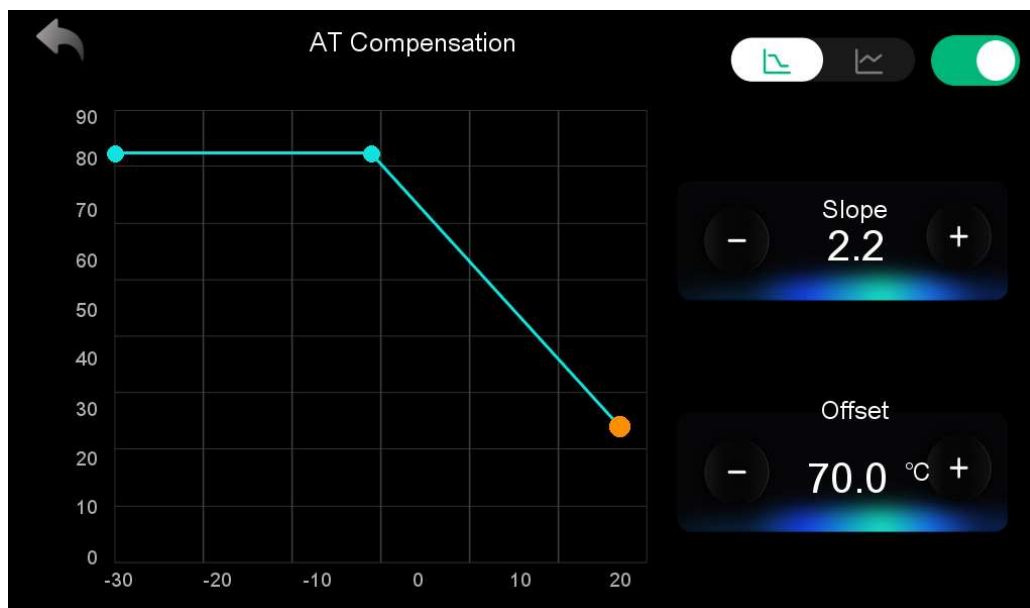

Selecting Multistage Weather compensation allows you to choose the flow temperature at various ambient temperatures.

Click on the desired ambient temperature and adjust the flow temperature using the +/- buttons, repeat the process for all ambient temperatures until the desired curve is achieved.

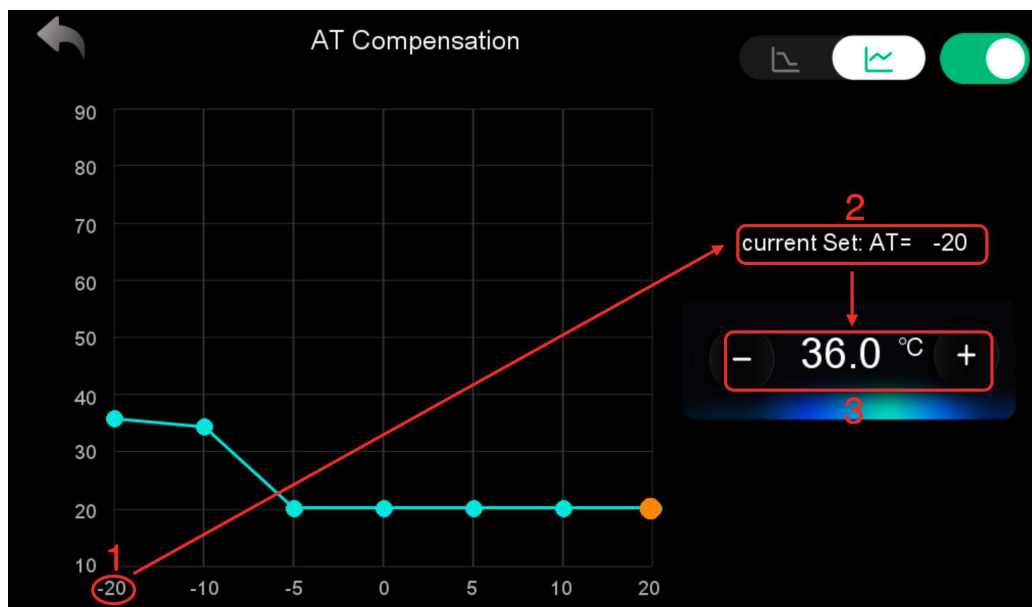

Maintenance

Before starting the unit for the first time or after long periods of being shut down please ensure.

1. The unit is inspected and cleaned.
2. The system is at the correct water pressure.
3. No air is present in the system.
4. The fins on the heat exchanger are in good condition and are clean with no blockages.

Cleaning

Make sure the unit has been powered OFF before any maintenance or cleaning is carried out.

1. Clean using a sponge and hot water with a mild detergent.
2. Do not use abrasive cleaners. Do Not use solvents. Do not use any cleaning agents that contain chlorine or ammonia.
3. Clean the fins using a soft brush, avoid bending the fins.
4. Check that condensate can drain freely from the base tray.

Periodic Maintenance

It is a requirement that the heat pump be serviced to the manufacturer's instructions. The system shall be serviced in line with the manufacturer's instructions annually and must be carried out by a competent MCS registered person.

Activair R290 Heat pump Annual Service Check list.

Heat pump Unit

1. Carry out electrical testing and safe isolation
2. Check all electrical supply connections for tightness.
3. Check visual condition of heat pump, confirm no damage and check panels for vibration.
4. Visual internal inspection for refrigerant and/or oil leaks.
5. Carry out sniffer test on internal pipework and components for leakage.
6. Visual inspection on circuit boards and electrical cabling for signs of damage.
7. Check and remove any obstruction to airflow on evaporator coil.
8. Inspect the coil and clean if required.
9. Comb fins straight if required.
10. Check condensate drain holes and pipes are clear.
11. Check fan condition.
12. Check if fan moves freely.

Heating Circuit

1. Check pipe insulation is in good condition.
2. If present, check flexible pipes are in good condition.
3. Check air bleed valves are operating correctly.
4. Check and clean strainer/magnetic filter.
5. Visually check PRV and termination of discharge correct.
6. Confirm primary system flow rate and delta T meets minimum requirements.
7. Note flow rate on service sheet.
8. Check/charge expansion vessel.

Domestic Hot Water Cylinder (If fitted)

1. Check the cylinder for any obvious defects.
 2. Check pipe work insulation.
 3. Check for signs of water leakage
 4. Check system water pressure is within limits. *
 5. Check the hot water outlet temperature closest to the cylinder to determine 10k NTC sensor accuracy.
 6. Check sensors are inserted into sensor pocket correctly and have heat transfer paste applied.
 7. Check any electrical wiring associated with the cylinder.
 8. Check high limit cut out on immersion heater.
 9. Check operation of immersion heater.
 10. Check operation of diverter valves.
 11. Clean line strainer of inlet group. *
 12. Check T&P and expansion valves are operating correctly. *
 13. Check/charge expansion vessel. *
 14. Check tundish drains and discharges correctly. *
- * G3 Certification required to carry out certain checks.

Interface Information

1. Check if parameters have been set up correctly and inline with system design. Consult the commissioning sheet.
2. Check if AT compensation has been enabled and set correctly in line with system design.
3. Record any fault codes on the service sheet.
4. Check time and date is set correctly.

Sign and date the service sheet and leave one copy with the heat pump.

Danger!

Risk of death caused by fire or explosion if there is a refrigerant leakage!

Only carry out the work if you are competent and have knowledge about the special features and risks of R290 refrigerant.

The product contains combustible refrigerant R290. In the event of a leak, escaping refrigerant may mix with air to form a flammable atmosphere.

In the event of a refrigerant leak the unit will operate the internal fan to disperse the refrigerant to outside.

The unit is equipped with a leak detection system for safety.

For leak detection to be effective the unit must be electrically powered at all times after installation, other than servicing.

Ensure that space is sufficiently aerated around the product.

Refrigerant Charge

All Trianco high temperature heat pumps are supplied pre charged with R290 refrigerant.

Please follow the steps below only if re-charging is required.

Please ensure a well-ventilated environment while charging the refrigerant.

Avoid open flames or potential sources of fire.

Disconnect the power supply to the heat pump.

Carefully check the heat pump's nameplate and charge according to the specified amount labelled.

Connect a vacuum pump to valve and run it until the absolute pressure falls below 30Pa or it has been operating for more than one hour.

Ensure the refrigerant is in a liquid state when charging and adhere strictly to the labelled amount.

After charging is complete make sure all connections are sealed.

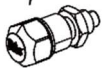
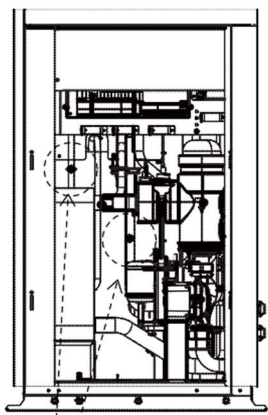

16mmAF

Fault Diagnosis

Issue	Possible Cause	Related Components	Solution
Unit trips MCB when powered on	Short circuit	Terminals Relays Contactors cables	Check all the component connections. Check relays and contactors. Disconnect the electronic components one by one and power on to find the problem
No Power to Display	Cables have disconnected. The power input cable is Damaged	Display cable Power input cable	Check the display cable. Check The Power cable.
Unit will Not start	Errors on display Disconnected Cables	Display Cables	Check the display for error codes. Check the cables.
Display will Not Work	The Display has been locked. The Display is damaged	Display	Unlock the Display Check Display cable.
Poor Heat	Compressor Issue Fan not running or speed is too low. Refrigerant leak	Compressor Fan Refrigerant System	Check correct operation of Compressor. Check fan speed. Check exhaust temperature and refrigerant pressure.
Unit shuts off before reaching Temperature	Weather Compensation	Control Logic	Check Parameters
Excessive Frost	Fan Blade or motor issue. EEV step is not suitable. Refrigerant amount incorrect Parameter Issue	Fan EEV Refrigerant System Parameters	Check fan speed. Check defrosting parameters. Check the compressor frequency. Check exhaust temperature and refrigerant pressure.
Abnormal Noise	Loose screws Fan blade or motor issue Compressor Issue Touching components	Screw Fan Compressor Other components	Check all screws are tight. Check fan blade and motor. Check compressor. Check other components.

Information Codes

Protect/fault	Fault display	Reason	Elimination methods
Inlet Water Temp. Sensor Fault	P01	The temp. sensor is broken or short circuit	Check or change the temp. sensor
Outlet Water Temp. Sensor Fault	P02	The temp. sensor is broken or short circuit	Check or change the temp. sensor
DHW Tank Sensor Fault	P03	The temp. sensor is broken or short circuit	Check or change the temp. sensor
AT Sensor Fault	P04	The temp. sensor is broken or short circuit	Check or change the temp. sensor
Suction Temp. Sensor Fault	P17	The temp. sensor is broken or short circuit	Check or change the temp. sensor
Heating Returning Water Temp. Sensor Fault	P013	The temp. sensor is broken or short circuit	Check or change the temp. sensor
DHW Returning Water Temp. Sensor Fault	P018	The temp. sensor is broken or short circuit	Check or change the temp. sensor
Heating Leaving Water Temp. Sensor Fault	P023	The temp. sensor is broken or short circuit	Check or change the temp. sensor
DHW Leaving Water Temp. Sensor Fault	P028	The temp. sensor is broken or short circuit	Check or change the temp. sensor
Room Temp. Sensor Fault	P42	The temp. sensor is broken or short circuit	Check or change the temp. sensor
EVI Inlet Sensor Fault	P101	The temp. sensor is broken or short circuit	Check or change the temp. sensor
EVI Outlet Sensor Fault	P102	The temp. sensor is broken or short circuit	Check or change the temp. sensor
Distributor Tube Temp. Sensor Fault	P152	The temp. sensor is broken or short circuit	Check or change the temp. sensor
Coil Temp. Sensor Fault	P153	The temp. sensor is broken or short circuit	Check or change the temp. sensor
Exhaust Temp. Sensor Fault	P181	The temp. sensor is broken or short circuit	Check or change the temp. sensor
Overhigh Exhaust Temp.	P182	The compressor is overload	Check whether the system of the compressor running normally
Anti-freezing Temp. Sensor Fault	P191	The temp. sensor is broken or short circuit	Check or change the temp. sensor
Mix Tube Outlet Water Temp. Sensor Fault	P02a	The temp. sensor is broken or short circuit	Check or change the temp. sensor
Buffer Tank Temp. Sensor Fault	P03a	The sensor is broken or short circuit	Check or change the temp. sensor
Pressure Sensor Fault	PP11	The pressure sensor is broken or short circuit	Check or change the pressure sensor or pressure
High Pressure Sensor Fault	PP12	The pressure sensor is broken or short circuit	Check or change the pressure sensor or pressure
Low AT Protection	TP	The ambient temp. is low	Check the ambient temp value
No Cooling at Low AT Protection	TC	The temp. sensor is incorrectly-detected or the temp. sensor is lower-than the set value A30	Check or change the temp. sensor
Electric Heater Overheat Fault	E04	The electric-heater protection switch is broken	Check whether the electric heater runs at the temperature above 150°C for a long time
Excess Temp. Diff. Between Inlet & outlet	E06	Water flow is not enough and low differential pressure	Check the pipe water flow and whether water system is jammed or not
Communication Fault	E08	Communication failure between wire controller and mainboard	Check the wire connection between remote wire controller and main board

Protect/fault	Fault display	Reason	Elimination methods
Primary Anti-freezing Fault	E19	The ambient temp. is low	Check the ambient temp value
Secondary Anti-freezing Fault	E29	The ambient temp. is low	Check the ambient temp value
Insufficient Defrosting Water Flow Alarm	E030	The unit flow rate is less than the minimum flow value of the unit.	Check or change waterway systems to provide unit flow
Flow Switch Fault	E032	No water/little water in water system	Check the pipe water flow and water pump
Overhigh Outlet Water Temp.	E065	No water/little water in water system	Check the pipe water flow and water pump
Low Outlet Water Temp. Temp. Fault	E071	No water/little water in water system	Check the pipe water flow and water pump
Fan Motor 1 and PCB Communication Fault	E081	Speed control module and main board communication fail	Check the communication connection
Fan Motor 2 and PCB Communication Fault	E082	Speed control module and main board communication fail	Check the communication connection
Display and PCB Communication Fault	E084	The wire controller software is not match the mainboard software	Check the wire control software number and the mainboard software number
Communication Fault with Hydraulic Module	E08c	Hydraulic Module and mainboard communication fail	Check the communication connection
HP Fault	E11	The high-pressure switch is broken	Check the pressure switch and cold circuit
LP Fault	E12	The low-pressure switch is broken	Check the pressure switch and cold circuit
Anti-freezing Fault	E171	Use side water system temp. is low	1. Check the water temp. or change the temp. sensor 2. Check the pipe water flow and whether water system is jammed or not
Fan Motor1 Fault	F031	1. Motor is in locked-rotor state 2. The wire connection between DC-fan motor module and fan motor is in bad contact	1. Change a new fan motor 2. Check the wire connection and make sure they are in good contact
Fan Motor2 Fault	F032	1. Motor is in locked-rotor state 2. The wire connection between DC-fan motor module and fan motor is in bad contact	1. Change a new fan motor 2. Check the wire connection and make sure they are in good contact
Zone 1 Room Temp. Sensor Fault	P105	The temp. sensor is broken or short circuit	Check or change the temp. sensor
Zone 2 Room Temp. Sensor Fault	P106	The temp. sensor is broken or short circuit	Check or change the temp. sensor
Zone 2 Mixing Temp. Sensor Fault	P107	The temp. sensor is broken or short circuit	Check or change the temp. sensor
Abnormal Adjustment of Mixing Valve	E122	1. Mixing Valve is incorrectly connected; 2. Mixing Valve is damaged;	1. Plug and unplug terminals; 1. Replace the Mixing Valve;
Zone 1 Thermostat Communication Fault	E08g	1. Thermostat not connected 2. Thermostat failure 3. Wrong parameter setting	1. Check the wiring connection between the thermostat and the unit 2. Replace the thermostat 3. Check the parameters
Zone 2 Thermostat Communication Fault	E08h	1. Thermostat not connected 2. Thermostat failure 3. Wrong parameter setting	1. Check the wiring connection between the thermostat and the unit 2. Replace the thermostat 3. Check the parameters
Low Water Flow Protection	E035	Water flow is too low	Increased water flow

Protection / Fault	Fault display	Reason	Elimination Methods
DHW Electric Heater Overheat Fault	E042	Overload protection switch disconnected when the electric heating of the hot water tank was activated.	Check the wiring of the electric heating overload switch in the hot water tank for proper connection and inspect the condition of the overload switch.
Overhigh Outlet Water Temperature after Electric Heater	E07a	High temperature detected at the water outlet of the electric heater during operation.	1. Verify whether the water outlet temperature of the electric heater exceeds 70°C. 2. Check the wiring of the temperature sensor at the electric heater outlet for proper connection.
Communication Fault with Indoor Unit	E08i	No successful communication detected with the indoor unit for 70 continuous seconds while indoor unit control is enabled.	1. If no indoor unit is installed, modify parameters to disable indoor unit control. 2. If an indoor unit is installed, inspect the communication wiring between the indoor unit and the heat pump for proper connection.
Communication Fault with Consumption Module	E08j	No successful communication detected with the consumption module for a continuous period while consumption module control is enabled.	1. If no consumption module is installed, modify parameters to disable consumption module control. 2. If a consumption module is installed, inspect the communication wiring between the consumption module and the heat pump for proper connection.
Water Pressure Sensor Fault (for IDU)	E034	Short circuit or open circuit detected by the indoor unit water pressure sensor.	1. Inspect the integrity of the indoor unit water pressure sensor. 2. Verify that the voltage at the water pressure sensor port is within the range of 0.5–4.5 V.
Refrigerant Leak	E131	Refrigerant leak detected	Check for leak
Temperature & Humidity Sensor Fault	T5T	Temperature sensor is open-circuit or short-circuit.	Check or replace the temperature sensor.
External Ambient Temperature Sensor Fault	T5Z	Temperature sensor is open-circuit or short-circuit.	Check or replace the temperature sensor.
Cooling Not Allowed Due to Large Temperature Difference Between Indoor and Outdoor Temperature	T5S	When dew point control is enabled and the outdoor temperature is less than the indoor temperature minus DP3, the heat pump temporarily disables cooling mode.	1. Wait for the indoor temperature to decrease or the outdoor temperature to increase; the fault will clear automatically. 2. Adjust parameter DP3 to change the indoor/outdoor temperature difference alarm threshold. 3. Disable the dew point control function (set DP1 = 0).

Protection / Fault	Fault display	Reason	Elimination Methods
IPM Overcurrent Fault	F00	IPM input current is too high.	Check and calibrate the current measurement circuit.
Compressor Driver Fault	F01	Phase loss, drive step fault, or driver hardware damage.	Check voltage measurements and inspect the inverter board hardware.
Pre-Charge Failure	F03	PFC circuit protection activated.	Check whether the PFC switching transistor is short-circuited.
DC Power Bus Overvoltage Fault	F05	DC bus voltage exceeds the overvoltage protection threshold.	Check the input voltage measurement.
DC Power Bus Undervoltage Fault	F06	DC bus voltage is below the undervoltage protection threshold.	Check the input voltage measurement.
AC Power Undervoltage Fault	F07	Input voltage is too low, resulting in insufficient input current.	Check the input voltage measurement.
AC Power Overcurrent Fault	F08	Input current exceeds the RMS overcurrent protection limit.	Check the input voltage measurement.
Input Power Voltage Sampling Fault	F09	Input voltage sampling circuit fault.	Check and calibrate the voltage measurement circuit.
AC Power Overvoltage Fault	F10	Input voltage exceeds the overvoltage protection threshold.	Verify that the input voltage is not higher than 265 V.
DSP and Compressor Driver Communication Fault	F11	Communication failure between the DSP and inverter board.	Check communication wiring and connections.
DSP and PFC Communication Fault	F12	Communication fault between the DSP and PFC board.	Check communication wiring and connections.
IPM Overheat Fault	F13	IPM module temperature is too high.	Check cooling conditions and current measurements.
Compressor Phase Loss Fault	F14	Compressor phase loss detected.	Check that compressor cables are connected properly and securely.
Input Power Phase Loss Fault	F15	Input power phase loss detected.	Check and measure the input supply voltage.
Compressor Weak Magnetic Alarm	F16	Compressor magnetic force is insufficient.	Check and calibrate the current measurement circuit.
Compressor Driver Temperature Sensor Fault	F17	Driver temperature sensor fault or overtemperature condition.	Check and calibrate the temperature sensing circuit.
IPM Current Sampling Fault	F18	IPM current sampling circuit fault.	Check and calibrate the current measurement circuit.
IGBT Power Device Overheat Alarm	F20	IGBT temperature is too high.	Check cooling conditions and current measurements.
Overspeed Fault	F21	Compressor operating speed is abnormal.	Check compressor wiring and verify that the compressor is not mechanically blocked.
AC Input Current Frequency Reduction Alarm	F22	Input current is too high.	Check and calibrate the current measurement circuit.
EEPROM Alarm	F23	MCU or EEPROM error.	Check whether the memory chip is damaged and replace it if necessary.
EEPROM Not Activated / Corrupted Fault	F24	MCU or EEPROM error.	Check whether the memory chip is damaged and replace it if necessary.
Input Power Current Sampling Fault	F25	+15 V supply is overvoltage or undervoltage.	Verify that the +15 V supply is within 13.5–16.5 V.
IGBT Overheat Fault	F26	IGBT temperature is too high.	Check cooling conditions and current measurements.
EEPROM Fault	F29	Failed to read the memory chip.	Check the inverter board and EEPROM device.
Compressor Current Frequency Reduction Alarm	F33	Compressor current limiting or frequency reduction activated.	Check and calibrate the current measurement circuit.
Compressor Type Code Fault	F060	Incorrect compressor model code selected.	Contact the supplier to obtain the correct compressor model code.
Driver (Fan) Phase Loss Fault	F101	Fan motor phase loss detected.	Check that fan cables are connected properly and securely.

Technical Details

Model	/	6kW	12kW	17kW
Nominal Heating Capacity (A)	kW	6	12	17
Heating Capacity Range (A)	kW	1.90-6.38	4.29-12.80	6.00-18.50
Heating Power Input Range (A)	kW	0.44-1.27	0.70-2.74	1.30-5.58
Nominal Capacity (B)	kW	6	12	17
Heating Capacity Range (B)	kW	1.06-6.72	4.35-12.16	6.00-18.00
Heating Power Input Range (B)	kW	0.65-2.12	0.94-3.80	1.80-5.45
Nominal Cooling Capacity (C)	kW	6	12	17
Cooling Capacity Range (C)	kW	2.05-10.05	4.63-17.99	6.00-23.00
Cooling Power Input Range (C)	kW	0.53-2.62	0.91-5.38	1.30-7.30
Nominal Cooling Capacity (D)	kW	6	12	17
Cooling Capacity Range (D)	kW	1.12-6.82	3.44-14.14	46129
Cooling Power Input Range (D)	kW	0.57-2.54	1.01-5.14	1.7-7.1
Max. Power Input	kW	3.5	6.09	8.74
Max. Current Input	A	15.5	26.68	38
Power Supply	/	220-240V~/50Hz	220-240V~/50Hz	220-240V~/50Hz
Refrigerant Type	/	R290		
Refrigerant Volume	kg	0.7	1	1.3
Compressor type	/	Rotary		
Compressor Quantity	/	1		
Fan Motor Type	/	DC Motor		
Fan Quantity	/	1	1	2
Sound Pressure (1m)	dB(A)*	33	36	35
Sound Power Level (EN12102)	dB(A)*	48	51	50
Sound Power Level (Night Mode)	dB(A)	46	50	51
Sound Power Level (Silent Mode)	dB(A)	45	49	49
Water Connection	inch	1		
Rated Water Flow	m ³ /h	1.03	2.06	2.92
Water Pressure Drop	kPa	12	23	40
Circulation Pump Head	m	7	7.8	10.4
Operating Ambient Temperature	°C	-30~45		
Unit Net Dimensions (L/W/H)	mm	See Drawings		
Unit Shipping Dimensions (L/W/H)	mm	See Data on Package		
Net Weight	kg	See Data on Nameplate		
Shipping Weight	kg	See Data on Package		

Heating working condition (A): (DB/WB)7°C/6°C. Outlet water temp.35°C. Heating working condition (B): (DB/WB)7°C/6°C. Outlet water temp.55°C. Cooling working condition (C): (DB/WB)35°C/24°C, Outlet water temp.18°C. Cooling working condition (D): (DB/WB)35°C/24°C, Outlet water temp.7°C.

BS EN14511-1-2013 Air conditioner, whole liquid cooling machine, electric compressor. Part2: Test condition; Part3: Test method; Part4: Related requirements.

*dB @ medium temperature application.

TEST SPECIFICATION

EN14511

EN14825

Activair R290 Heat Pump Commissioning Check List

It is a requirement that the heat pump be installed and commissioned to the manufacturer's instructions. The warranty must be registered with the manufacturer and in accordance with the terms and conditions. The Commissioning Check list is to be completed in full by the competent person who commissioned the system as a means of demonstrating compliance with the appropriate Building Regulations.

Company Name	
Company Address	
Service Engineer	
Contact Number	
Install Address	
Model & Serial Number	
Commissioning Date	

Installation

DNO Notified	YES	NO
Installation Compliant with Build Regulations	YES	NO
Time & Temperature control provided for all circuits	YES	NO
Interlock Provided	YES	NO
Water Quality Check Completed	YES	NO

System property Heat loss (kW) @ outdoor design temperature	
---	--

Please Provide a brief description to how the system is installed.	
--	--

User Interface Parameters.

(Add values set)

Flow Temperature Slope	
Flow Temperature Offset	
H07	
H20	
H25	
H37	
P01	
P02	
P03	
P10	
P11	
G01	
G02	
G03	
G04	
G05	

AT Compensation Enabled	YES	NO
-------------------------	-----	----

Heating System Information

System Balanced	YES	NO
Auto Bypass fitted and set	YES	NO
Heating Expansion vessel Fitted and set correctly	YES	NO
System Flushed and Cleansed	YES	NO
Heating System Frost Protection	YES	NO
Primary System flow rate		M3/H

Declaration

Installer signature: <i>I can confirm the installation has been installed and commissioned in accordance with the above checklist</i>	
Print Name:	

Notes



TRIANCO

BRINGING HEAT TO LIFE

TR ENGINEERING LTD
5 Wortley Road
Rotherham
S61 1LZ
Tel: (0114) 2572300
Fax: (0114) 2571419
www.trianco.co.uk

© TR Engineering Limited

Copyright in this brochure and the drawings and illustrations contained in it is vested in TR Engineering Limited and neither the brochure or any part thereof may be reproduced without prior written consent.

TR Engineering Limited's policy is one of continuous research and development. This may necessitate alterations to this specification.

06/2026