

TRIANCO



OIL FIRED CENTRAL HEATING BOILERS
FOR BALANCED OR CONVENTIONAL FLUE



TRIANCO

CE BED 92/42 EEC
EMC 89/336 EEC

USER, INSTALLATION COMMISSIONING & SERVICING INSTRUCTIONS

EUROSTAR 2000
50-65
70-90

To be retained by householder

HEALTH AND SAFETY

INFORMATION FOR THE INSTALLER AND SERVICE ENGINEERS

Under the Consumer Protection Act 1987 and the Health and Safety at Work Act 1974, it is a requirement to provide information on substances hazardous to health (COSHH Regulations 1988).

The Company takes every reasonable care to ensure that these products are designed and constructed to meet these general safety requirements, when properly used and installed.

To fulfil this requirement products are comprehensively tested and examined before despatch.

This appliance may contain some of the items below.

When working on the appliance it is the Users/Engineers responsibility to ensure that any necessary personal protective clothing or equipment is worn appropriate to parts that could be considered as being hazardous to health and safety.

INSULATION AND SEALS

Glass Rope, Mineral Wool, Insulation Pads, Ceramic Fibre, Glass Insulation.

May be harmful if inhaled. May be irritating to the skin, eyes, nose or throat. When handling avoid inhalation and contact with eyes. Use (disposable) gloves, face masks and eye protection.

After handling wash hands and other exposed parts. When disposing, reduce dust with water spray, ensure parts are securely wrapped.

GLUES, SEALANTS & PAINT

Glues, Sealants and Paints are used in the product and present no known hazards when used in the manner for which they are intended.

KEROSENE & GAS OIL FUELS (MINERAL OILS)

1. The effect of mineral oils on the skin vary according to the duration of exposure.
2. The lighter fractions also remove the protective grease normally present on the surface of the skin rendering the skin dry, liable to crack and more prone to damage caused by cuts and abrasions.
3. Skin rashes (oil acne). Seek immediate medical attention for any rash, wart or sore developing on any part of the body, particularly the scrotum.
4. Avoid as far as possible any skin contact with mineral oil or with clothing contaminated with mineral oil.
5. Never breathe any mineral oil vapours. Do not fire the Burner in the open i.e. out of the Boiler as a misfire will cause unburnt oil vapours.
6. Barrier cream containing lanolin such as Rosalex Antisolv, is highly recommended together with a strict routine of personal cleaning.
7. Under no circumstances should mineral oils be taken internally.

TRIANCO

CUSTOMER AFTER SALES SERVICE INFORMATION

A step by step guide to reporting a fault with your appliance

A qualified field SERVICE ENGINEER is available to attend a breakdown or manufacturing fault occurring whilst the appliance is under guarantee.

The appliance must be made available for service during normal working hours, Monday to Friday (no weekend work is accepted).

A charge will be made where:

- Our Field Service Engineer finds no fault with the appliance
or
- The cause of a breakdown is due to other parts of the plumbing/heating system (including oil line/lack of oil), or with equipment not supplied by Trianco.
or
- Where the appliance falls outside the guarantee period (see terms and conditions enclosed).
or
- The appliance has not been correctly installed, commissioned or serviced as recommended (see commissioning, installation and servicing instructions)
or
- The breakdown occurs immediately following an annual service visit. In this instance your appointed Service Agent must check all his work PRIOR to requesting Trianco to attend.

NOTE: Burner nozzles are currently guaranteed until the first service.

Over 50% of all service calls made are found to have no appliance fault.

What to do in the event of an appliance fault or breakdown:

Step 1: Always contact your installer or commissioning engineer in the first instance, who must thoroughly check all his work PRIOR to requesting a service visit from Trianco.

Step 2: If your appliance has developed an in-guarantee fault your installer should contact Trianco Service Centre for assistance.

What happens if my installer/engineer is unavailable?

Step 3: Contact Trianco Direct. We will provide you with the name and telephone number of our Service Agent. However, a charge may apply if the fault is not covered by the appliance guarantee (payment will be requested on site by our independent Service Agent).

PLEASE NOTE:

Unauthorised invoices for attendance and repair work carried out on this appliance by any third party will not be accepted by Trianco.

SERVICE CENTRE AND TECHNICAL SUPPORT

Tel: 0114 257 2300 Fax: 0114 257 2338

Hours of business Monday to Thursday 8.30am - 4.45pm

Friday 8.30am - 2.30pm

CONTENTS

	PAGE
1. USER INSTRUCTIONS	1/2
After sales service information	3
2. INTRODUCTION	4
3. TECHNICAL INFORMATION	5
Outline Dimensions	5
Technical specifications	6
4. INSTALLATION	8
Regulations	8
Health and Safety	8
Siting the Boiler	8
Ventilation (Conventional flue boilers)	8
Ventilation (room sealed balanced flue boilers)	9
Extractor fan	9
Heating and domestic hot water system	9
Electrical supply	9
Thermostats	9
5. OIL SUPPLY	10
Oil storage tank - Steel and Plastic	10
Oil supply line	10
Single pipe oil supply	10
Two pipe oil supply	10
Oil De-aerator - Single pipe supply	10
6. FLUE SYSTEM	13
Conventional chimney	14
Balanced flue (Room sealed) optional extra	14
2270 & 2271 Horizontal telescopic BF kit	15/16
Assembly notes	17
2270 High level adaptor kit	18
Assembly method	19
2272 Universal BF Kit	20
2273 Vertical BF kit	21
Assembly method	22
2273 Universal BF Kit	23
7. COMMISSIONING	24
Procedure	24
Handing over	24
8. SERVICING	24
Oil Tanks	24
Line Filters	24
Burner	24
Boiler	25
9. FAULT FINDING	26/27
10. SPARES	28
Boiler parts	29

HOW TO USE YOUR TRIANCO BOILER

The Trianco EuroStar has been designed and constructed to give years of trouble free service and these instructions are provided to assist you in obtaining the best performance with the least trouble and cost.

The boiler is fully automatic in operation and requires little attention other than the setting of the thermostat and any system controls such as a room thermostat and time-switch.

TO FIRE THE BOILER

Before firing the boiler, ensure the system is full of water, there is sufficient oil in the storage tank and all valves are open.

1. Check that the Time-switch/Programmer (if fitted) is ON and the room thermostat is calling for heat.
2. Set the boiler thermostat to the desired temperature.
3. Switch on the electrical supply to the boiler and the burner should fire after a few seconds of fan pre-purge.
4. Set the Time-switch/Programmer (if fitted) to the times and programme required.
5. The boiler will now operate automatically, cutting in and out according to the heat demand.

TO STOP THE BURNER

The burner may be stopped by turning the Boiler Control Thermostat fully anti-clockwise to the OFF position 'O'

If the boiler is to be off for a long time, it is recommended that the mains supply to the boiler is switched off or the Time-switch/Programmer (if fitted) is switched to the OFF position.

BOILER CONTROL THERMOSTAT

The boiler control thermostat enables you to select the temperature of the water leaving the boiler. Temperature range of 82° C (high) to 55° C (low).

Set the temperature by turning the knob to the required temperature. However, the installer should take into consideration that the return water temperature **must not** drop below 60°C when the appliance is up to full operating temperature.

The thermostat is switched off when the knob is turned fully anti-clockwise with pointer opposite 'O'

HIGH LIMIT THERMOSTAT (Hand Reset)

The high limit thermostat is factory set and requires no adjustment. Should the boiler thermostat malfunction, the limit thermostat will take over and shut down the boiler.

If the limit thermostat operates frequently, consult your Service Engineer as there may be a fault in the system.

To reset the limit thermostat, remove the front panel and push in button.

Note: The limit thermostat can only be reset when the water temperature has dropped at least 20° C.

BURNER LOCK-OUT

If the burner fails to light, it will go to lock-out. If this occurs, wait about one minute then remove the front panel and press illuminated reset button to start burner. In the event of the burner not firing wait a further minute and then press the reset button again. If the burner still fails to start, switch off the electrical supply to the boiler.

WARNING - DO NOT ATTEMPT TO START BURNER MORE THAN TWICE

(See Simple Fault Finding before contacting your Service Engineer).

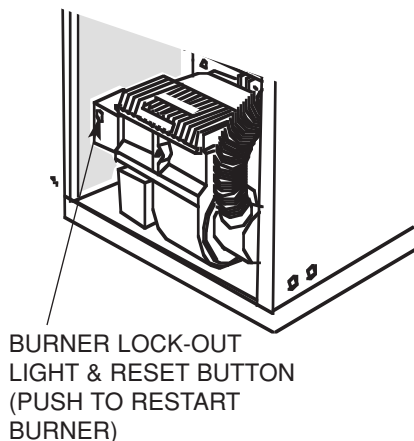
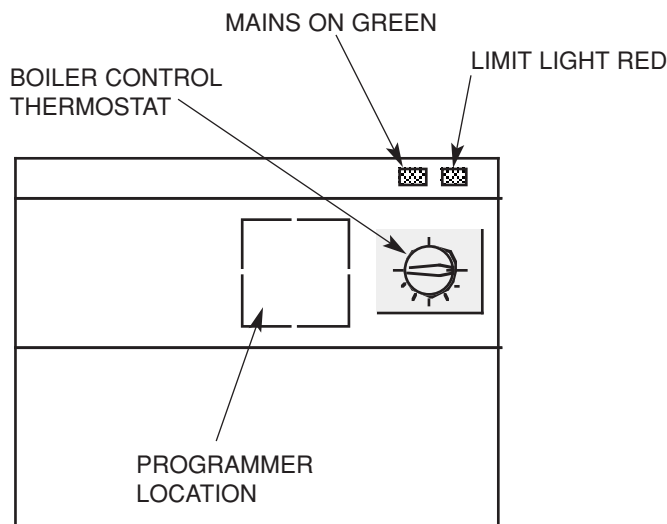

SYSTEMS CONTROLS

ROOM THERMOSTAT

The room thermostat should not be positioned near a source of heat such as a radiator or exposed to the sun as this will cause the central heating to switch off before the room is up to temperature. Follow the manufacturer's instructions for best siting position for the thermostat.

TIME-SWITCH/PROGRAMMER

When choosing the operating times for your boiler, it is useful to remember that central heating usually takes between half an hour to an hour before it becomes effective.

It is suggested that the Time-Switch/Programmer is set to bring on the heating about an hour before heating is required.

It is also worth noting that the heating system will usually remain effective for up to half an hour after boiler shut down. The timer can therefore be switched off earlier as an economy measure.

FROST PROTECTION

If the boiler and central heating is shut down for many hours during very cold weather, the water may be in danger of freezing and, as such, it is advisable to protect the installation with a frost thermostat.

Where the system is not protected, the boiler should be left switched on and the room thermostat set to a low setting e.g. 7° C (45° F) to prevent the building temperature falling too low.

If the system is shut down for a long period during very cold weather, it is advisable to completely drain the system. However, frequent draining should be avoided, especially in hard water areas, as this could lead scaling of the boiler waterways.

SHUTTING DOWN FOR THE SUMMER

If the boiler is shut down for the summer months, it is advisable to have it serviced and thoroughly cleaned as soon as possible to minimise corrosion of the heating surfaces.

OIL

The recommended oil for your boiler is 28 sec.Kerosene (BS 2869:1983 Class C2).

OIL TANK

Always ensure the tank is topped up at regular intervals, do not wait until the tank is nearly empty before refilling, otherwise sludge and water could be sucked into the oil pipe to affect the burner's operation and reduce pump life.

After a delivery of oil, it is recommended that the oil is allowed to settle in the tank for about half an hour before restarting the burner.

Sludge and water caused by condensation should be drawn off at the tank drain-cock annually.

SIMPLE FAULT FINDING

If the burner fails to start for no apparent reason, make the following checks before calling your Service Engineer.

1. Check for failure in the electrical supply e.g. a power cut
2. Check for a blown fuse. If the fuse has blown and on replacement blows again, switch off the mains electrical supply to the boiler and call your Service Engineer.
3. Check that there is adequate oil in the tank and the shut-off valves are open.
4. Check for burner lock-out. Press the reset button and burner should fire. **DO NOT PRESS MORE THAN TWICE.** Refer to 'Burner lock-out' for further advice.
5. Check for excess water temperature (Refer to 'High Limit Thermostat' for advice).

Note: If the boiler has been off as a result of a power failure, it will be necessary to reset the Time Switch/Programmer to the correct time unless it has a built-in power reserve.

SERVICING

To ensure efficient and reliable operation of the boiler, it is essential that the oil burner is initially commissioned by a qualified engineer and an annual service is given thereafter, by an OFTEC trained and registered engineer.

Notes:

ELECTRICAL SAFETY CHECKS SHOULD BE CARRIED OUT BY A QUALIFIED ELECTRICAL ENGINEER

- (a) It is the responsibility of the Installer to ensure proper commissioning is carried out.
- (b) It is a requirement of the boiler's guarantee and any extended warranty that an annual service is carried out by a qualified engineer.

Commissioning Engineer's
Signature.....

Company Name.....

.....

Address.....

.....

.....

Tel. No:.....

TRIANCO

CUSTOMER AFTER SALES SERVICE INFORMATION

A step by step guide to reporting a fault with your appliance

A qualified field SERVICE ENGINEER is available to attend a breakdown or manufacturing fault occurring whilst the appliance is under guarantee.

The appliance must be made available for service during normal working hours, Monday to Friday (no weekend work is accepted).

A charge will be made where:

- Our Field Service Engineer finds no fault with the appliance
or
- The cause of a breakdown is due to other parts of the plumbing/heating system (including oil line/lack of oil), or with equipment not supplied by Trianco.
or
- Where the appliance falls outside the guarantee period (see terms and conditions enclosed).
or
- The appliance has not been correctly installed, commissioned or serviced as recommended (see commissioning, installation and servicing instructions)
or
- The breakdown occurs immediately following an annual service visit. In this instance your appointed Service Agent must check all his work PRIOR to requesting Trianco to attend.

NOTE: Burner nozzles are currently guaranteed until the first service.

Over 50% of all service calls made are found to have no appliance fault.

What to do in the event of an appliance fault or breakdown:

Step 1: Always contact your installer or commissioning engineer in the first instance, who must thoroughly check all his work PRIOR to requesting a service visit from Trianco.

Step 2: If your appliance has developed an in-guarantee fault your installer should contact Trianco Service Centre for assistance.

What happens if my installer/engineer is unavailable?

Step 3: Contact Trianco Direct. We will provide you with the name and telephone number of our Service Agent. **However, a charge may apply if the fault is not covered by the appliance guarantee (payment will be requested on site by our independent Service Agent).**

PLEASE NOTE:

Unauthorised invoices for attendance and repair work carried out on this appliance by any third party will not be accepted by Trianco.

SERVICE CENTRE AND TECHNICAL SUPPORT

Tel: 0114 257 2300 Fax: 0114 257 2338

Hours of business Monday to Thursday 8.30am - 4.45pm

Friday 8.30am - 2.30pm

2. INTRODUCTION

The Trianco EuroStar 2000 Boiler has been designed to conform to European Directive/Standards BED 92/42 EEC LVD EN 60335-1 EMC 89/336/EEC.

The matched pressure jet burner which is exceptionally quiet in operation, ensures clean and efficient combustion with low NO_x emissions.

The EuroStar 2000 balanced flue boiler is suitable for installation in a garage.

The EuroStar boilers are suitable for all normal open vented central heating and indirect hot water systems and can also be used with sealed systems up to a working pressure of 3 bar with the appropriate sealed system safety equipment.

Two flow and return sockets are provided to facilitate connection to the heating and hot water systems.

Due to high efficiency of this range of boilers; it is recommended that they are filled on fully pumped system using diagonally opposite connections of the heat exchanger.

All servicing can be carried out from the front of the boiler, thus allowing the boiler to be fitted under a kitchen work top if required. The front mounted flue-cover permits easy access for the removal of the flue-baffles and cleaning of heating surfaces.

Important Notice:

To comply with Building Regulations Part L1, when installed your new boiler or hot water storage system must either have the installation approved by the local Building Control Body, or a fully completed commissioning certificate must be left on site. This can only be completed by an OFTEC registered technician.

This appliance must be installed on a fully pumped system only and be fitted with an automatic thermostatically controlled bypass to prevent a return temperature of less than 60°C. This is a requirement of the Building Regulations, Section L. Failure to comply with this requirement will invalidate your warranty.

THE PERSON(S) WHO INSTALLS THIS APPLIANCE, COMMISSIONS, SERVICES OR CARRIES OUT ANY REMEDIAL WORK, IE ELECTRICAL FAULT FINDING, MUST HAVE SUITABLE ENGINEERING QUALIFICATIONS

The boiler is fully automatic in operation and incorporate all necessary safety controls to ensure safe and reliable operation.

Trianco EuroStar boilers are supplied with the burner set for Kerosene 28 sec. Class C fuel to meet the Building Regulation requirements for low level flue discharge. It is recommended this fuel is also used when the boiler is connected to a conventional chimney because of the clean burning characteristics of Kerosene.

Balanced Flue Kits

The boilers are supplied suitably equipped for connection to a conventional chimney, but can readily be converted into a room-sealed balanced flue appliance by using a Trianco balanced flue kit. These kits allow the boiler to be installed in a wide variety of site conditions, from low-level discharge through the wall, to high-level discharge (see balanced flue kit details - section 6).

Two distinct styles of flue kit are available. The circular balanced flue kit is available in both low-level horizontal and vertical set-ups. The square balanced flue kit is available in a low-level horizontal format and a high-level horizontal format (in conjunction with a circular vertical adaptor kit).

Note:

Both the square and circular low level horizontal balanced flue kits can be used for left-hand, right-hand, and rear exhaust.

3. TECHNICAL INFORMATION

ALL DIMENSIONS
IN MILLIMETRES

MODEL	A	B
50/65	402	860
70/90	462	860

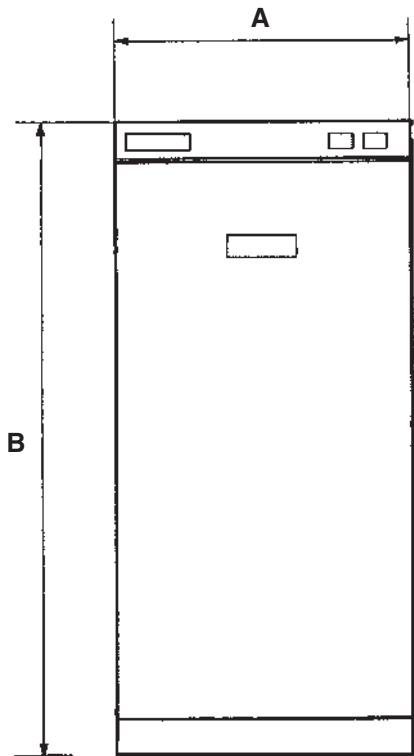
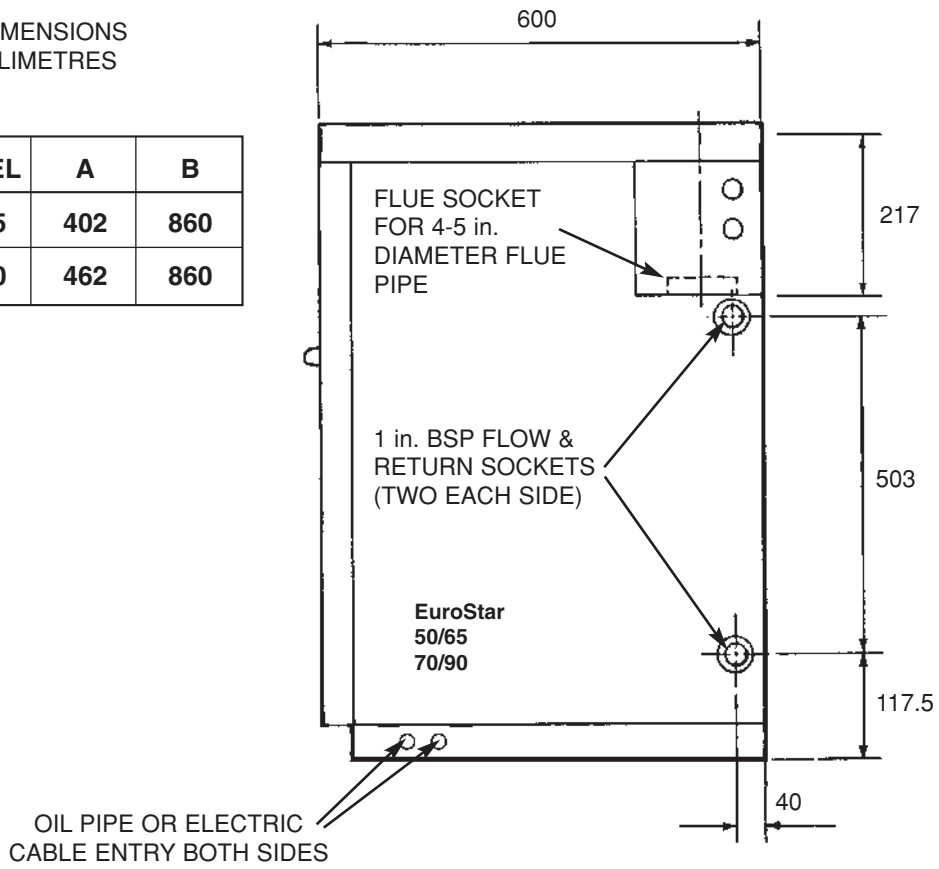

Fig. 1 OUTLINE DIMENSIONS

Technical Specification

EuroStar 2000 Boiler Models	Units	50/65	70/90	
Rated Input	(Btu/h) (kW)	74,000 21.7	98,000 28.6	
Rated Output	(Btu/h) (kW)	65,000 19	90,000 26.4	
Burner		See Burner Details	See Burner Details	
Weight (empty)	(kg)	82	100	
Water content	(litre)	20	22	
Flow & return sockets	(in.)	4 x 1 BSP	4 x 1 BSP	
Flue Socket Dia. (C.F.)	mm (in.)	100 or 125 4 or 5	100 or 125 4 or 5	
Max. operating pressure	(bar) (psi)	3 43.5	3 43.5	
Test Pressure	(bar) (psi)	4.5 65.3	4.5 65.3	
Water side resistance 10 diff 20 diff	(mbar) (mbar)	21.3 5.2	25.0 8.3	
Starting Current	(amp)	3.5	3.5	
Running Current	(amp)	0.77	0.77	
Control Thermostat	- Adjustable up to and 82°C			
Limit Thermostat	- Factory set at 110°C (hand reset)			
Casing Finish	- Stove enamelled white with coloured facia trim			
Thermal Insulation	- Boiler shell insulated with fibre glass			
Optional Extras	- Trianco Balanced Flue Kits			

CONTROL BOX WIRING

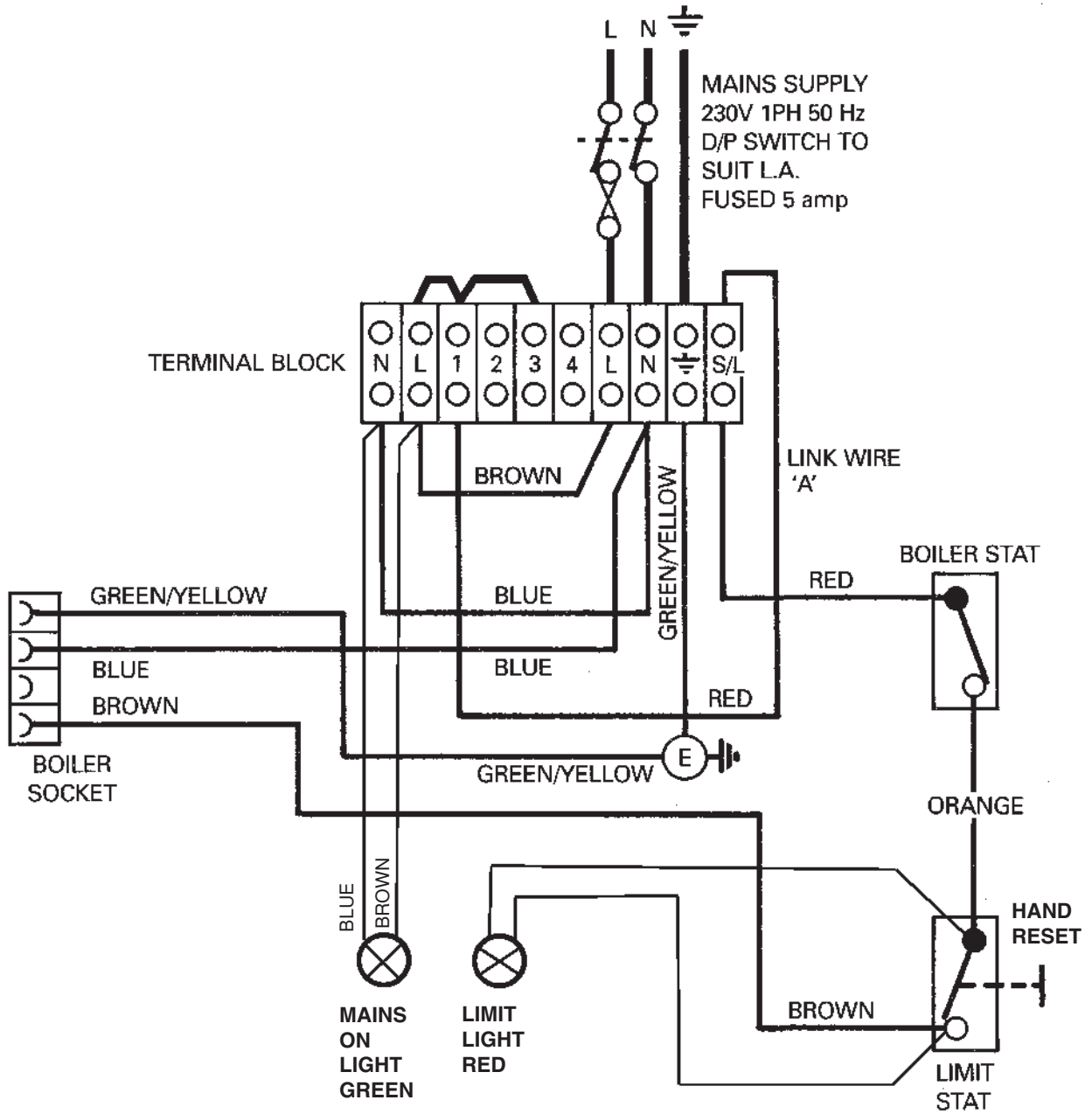

FIG. 2 WIRING DIAGRAM

4. INSTALLATION

Regulations

Installation of the boiler must comply with the following British Standards and Regulations:

BS 5410: Part 1 - Code of Practice for Oil Firing.

BS 5449 - Forced Circulation Hot Water Central Heating Systems.

The Building Regulations - Part 'J' (England and Wales)
Part 'F' Section 111 (Scotland)
Part 'L'

The Control of Pollution (Oil) Regulations
Current I.E.E. Regulations
Local Water Undertakings By-laws
OFTEC Installation Requirements for Oil Fired Boilers and Oil Storage Tanks.

Health and Safety at Work Act

The installer should be aware of his responsibilities under the Act and provide, where necessary, appropriate protection for persons carrying out the installation.

In the interest of safety, the boiler should be installed and commissioned by a competent engineer, OFTEC trained and registered.

A useful guide to 'Safe Working Practices for Oil Firing Technicians' is published by OFTEC.

ELECTRICAL WORK SHOULD BE CARRIED OUT BY A QUALIFIED ELECTRICAL ENGINEER

Siting the Boiler

Sound Levels

Whilst the low sound level of the Trianco EuroStar boiler makes it eminently suitable for kitchen and utility room installation, the following aspects should be considered before installation:

- Some people are particularly sensitive to even low noise levels so this aspect should be discussed with the householder.
- Small rooms tend to amplify noise, particularly if the wall construction is hollow or the surface tiled.
- A chimney passing through a bedroom can sometimes transmit noise.
- Low level flue terminals produce some exhaust noise, so care should be taken when siting adjacent to neighbouring property.

Clearance and Service Access

When siting the boiler, ensure adequate clearance is allowed for making water and flue connections. As the boiler can be fully serviced from the front, there is no need for a headroom allowance nor provision for removal of the kitchen work top but a clearance of at least 750mm is required at the front of the boiler.

Hearth

The boiler must be fitted on a non-combustible base. Also the floor must be level and capable of supporting the installed weight of the boiler, including its water content.

Combustion Air (Conventional flue boilers)

The provision of an adequate supply of combustion air is essential for the efficient and safe operation of the boiler. The air opening should be positioned so as to cause the least possible draught to the occupants and located so it is not liable to be accidentally blocked.

British Standard Code of Practice for Oil Firing BS 5410: Part 1 requires a permanent air inlet opening of 550mm² per kW of boiler rated output.

See Fig. 4 for air openings required for Trianco EuroStar boilers:

Ventilation (Conventional flue boilers)

Where the boiler is installed in a compartment or a confined space, ventilation openings are also required to prevent overheating of the appliance controls (the ventilation areas are shown in Fig 4).

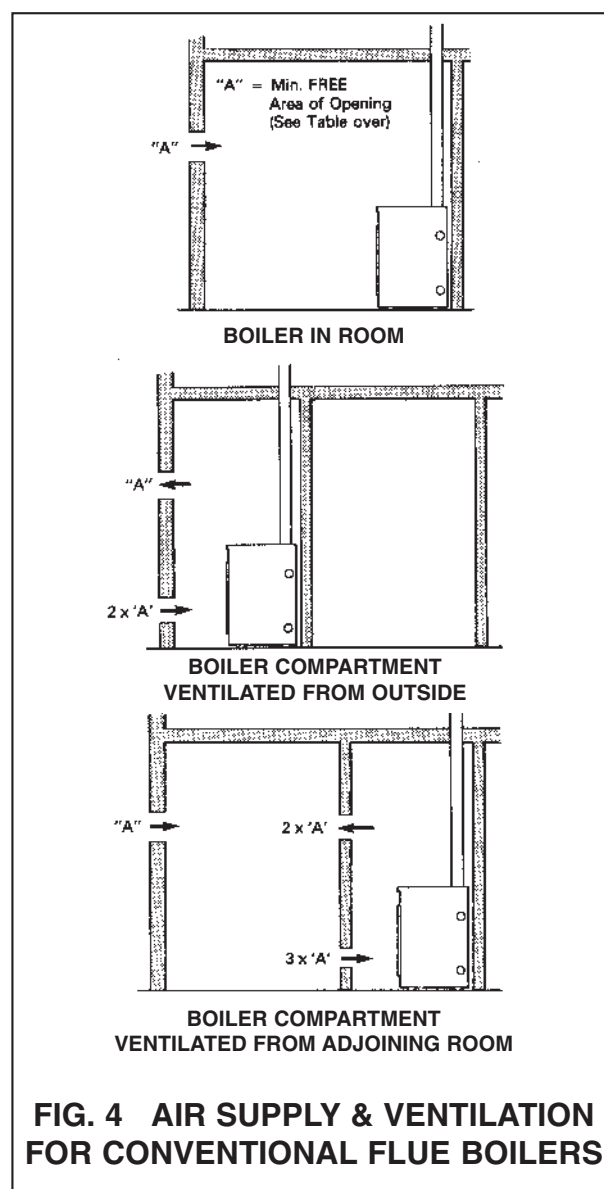

Ventilation (Room sealed balanced flue boilers)

Although no openings are required for the supply of combustion air (this comes from outside through the air duct system direct to the burner), ventilation is, however, necessary if the boiler is installed in a compartment or a confined space in order to prevent overheating of the boiler controls (See Fig.5 for ventilation openings).

FIG. 5

EuroStar Model	Minimum FREE Area opening 'A'
50/65	105CM ² (16in ²)
70/90	145CM ² (22in ²)

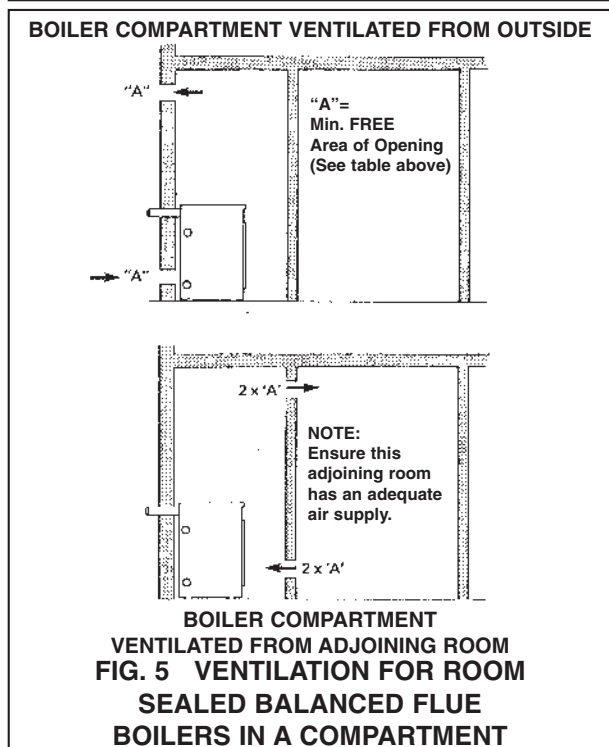

Extractor Fan (conventional flue only)

If the boiler room has an extractor fan, the combustion performance of the appliance must not be affected when the fan is running and all doors and windows are closed. A flue gas check on the CO₂% and smoke number should be carried out to prove that combustion is satisfactory.

Heating and Domestic Hot Water Systems

The heating system should be installed in accordance with current HVCA Codes of Practice and BS 5449 Part 1 'Forced Circulation Hot Water Systems'.

Water connections can be made to the boiler using both pairs of flow and return tappings or, alternatively, single diagonally opposite tappings can be used.

Due to high efficiencies of this range of boilers, it is recommended that they are fitted on fully pumped system using diagonally opposite connections. Fit drain-off cock in the lowest part of the system. Where a boiler is also used for providing domestic hot water, a double feed indirect cylinder to BS 1566 Part 1 must be used.

MAKE SURE ALL UNUSED BOILER TAPPINGS ARE PLUGGED BEFORE FILLING THE SYSTEM.

Flush out the system to remove any swarf or residues before fitting circulating pump.

PLEASE NOTE:

If the boiler is to be installed on a gravity type system care must be taken, i.e. due to the high efficiency of the Trianco Eurostar boiler consideration should be given to gravitational flows with view to system contamination and operation.

Failure to comply with these recommendations may result in there being a temperature build-up within the boiler/system causing noisy operation.

Electrical Supply

230V 1 Phase 50Hz (Fused 5 Amp)

Note: THIS APPLIANCE MUST BE EARTHED

All electrical wiring must be carried out by a qualified electrician in accordance with current I.E.E. Regulations and any Local Regulations that may apply.

The 230v - 50Hz electrical supply must be fused by a double pole switch with a contact separation of at least 3mm in both poles, and shuttered socket (both complying with the requirements of BS 1363) adjacent to the boiler. Fuse supply at 5A. The minimum requirement for the power supply cable should be a PVC sheathed flexible cord, at least 0.75mm² (24x0,2mm) (code designation H05 VV-F or H05 VVH2-F) as specified in table 16 of BS 6500.

This appliance MUST be earthed and the electrical supply earth cable must be of a greater length than the current carrying conductor cables (ie live and neutral supply cables).

All external cables entering the control box must be secured in position by strain relief bushes supplied (see diagram on how to secure cable).

Terminal connections are also provided in the control panel for ancillary controls.

See wiring diagram Fig. 2

Warning - High and Low Voltage

In certain parts of the country, where there is a known risk of high or low voltage fluctuations, the oil burner shall be prevented from starting by the use of a voltage sensitive device if the voltage drops or increases sufficiently to endanger the installation.

Thermostats

The boiler is fitted with a variable setting control thermostat and a pre-set limit thermostat. Should the boiler thermostat malfunction, the limit thermostat will take over control and shut down the boiler.

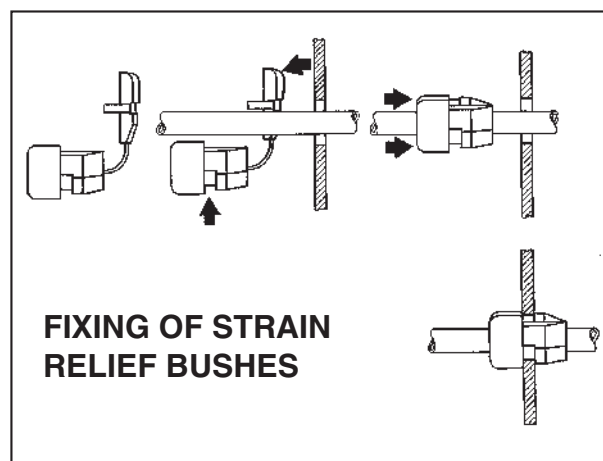

5. OIL SUPPLY

Oil

The oil burner is factory set to burn 28 sec. Kerosene.

Note: Only Kerosene is permitted for low level flue discharge.

Oil Storage Tanks

Size and Location of Tank

The tank should be large enough to allow for economic deliveries and be located in the most unobtrusive position, having regard to the need for safety, filling, maintenance (if steel tank) and the head of oil required.

Whilst it is highly unlikely that a fire could start from a domestic oil tank, it does however need to be protected from a fire that may originate in a nearby building, therefore the tank should not be located nearer than 1.8 metres from a building, nor closer than 760mm from a site boundary. Where a tank has to be less than 1.8 metres, the building wall must not have any openings other than small ventilation openings. The wall shall have a half hour resistance to an internal fire and extend 1.8 metres from any part of the tank.

Alternatively, a non-combustible radiation barrier must be provided which meets the requirements of BS 5410 Part 1: This standard applies to tanks up to a capacity of 3,400 litres which is deemed the maximum size for a single family dwelling.

Steel Tanks

Steel tanks should comply with the requirements BS 799, Pt. 5: 1987 and mounted on brick or block piers with a waterproof membrane between the piers and tank.

The tank should be fitted with fill and vent connections (weather protected), a drain-off cock, shut-off valve and an oil level indicator.

Plastic Tanks

Polyethylene tanks are now widely used because of their advantages over traditional steel tanks:

- They do not need pier supports and can be mounted directly on any flat surface giving uniform support for the tank base.
- They do not corrode and therefore never need painting.
- They are easier to handle because of their lower weight.
- They have a 10 year manufacturer's guarantee.

Plastic tanks should be fitted with similar components to those used with steel tanks.

Fire Protection

To comply with building regulation **Section J5:**

- Where a storage tank is close to a dwelling, fire cladding must be provided to the eaves, if less than 1.8m from the top of the tank.
- The cladding must extend 300mm beyond the tank.
- The tank must be sited on a non-combustible base.

Pollution Protection

To comply with building regulation **section J6**, the tank must be 'bunded' (i.e. double walled) if:

- The tank is less than 10m from a stream.
- The tank is less than 50m from a well, spring, or drinking water.
- The tank cannot be viewed from the delivery point.
- In the event of a leak, there is a risk of oil reaching a manhole cover or drain.
- The tank capacity exceeds 2500 Litres.

Oil supply line

A long life flexible oil hose is supplied with the boiler, a filter and shut-off valve are required. These should be fitted as shown in Figs. 6 and 7.

The oil shut-off valve should be fitted as close to the burner as practicable to enable the burner to be disconnected without undue loss of oil. The filter must be connected in the oil supply pipe and positioned either inside or outside the building.

Fire Valve

A fire-valve must be fitted in the oil line outside the building with its sensing phial positioned within the boiler casing below the control panel. A clip is provided for retaining the phial.

All oil line joints must be completely sealed and the total pipe run thoroughly flushed out before connecting to the burner. No soldered joints are permitted in the oil line.

The oil line can be fed into the back of the boiler base tray or through the holes at the side.

Single pipe oil supply (Fig. 6)

When, the bottom of the oil supply tank is above the burner, a single pipe gravity system can be used. The oil supply pipe must be connected to the suction port on the burner pump via the flexible hose.

Two pipe oil supply (Fig. 7)

Where, the bottom of the oil storage tank is below the burner, a two pipe suction lift system is necessary.

On the BFP II pump remove the end cover and filter, then remove the 'U' washer by unscrewing the bottom screw, then replace the screw ensuring it is fully inserted. An additional flexible hose is also required.

A spring loaded non- return valve must be fitted in the suction line to stop the oil running back to the tank. A filter, shut-off valve and fire valve must also be fitted in the line.

No valves are permitted in the return line which must remain unobstructed at all times.

Notes:

- The pump suction should not exceed 0.4 bar, otherwise dissolved gas will be released from the oil to affect combustion.
- The return pipe must end at the same level as the suction outlet to prevent loss of prime.
- The outlet from the tank should be approximately 75mm (3 in) above the bottom to prevent sediment and water being drawn into the supply pipe.

Oil De-aerator - Single pipe supply (Fig. 8)

Where a two pipe suction lift system is required, but the return pipe is too long, or impractical to run, an Oil De-aerator can be used. The burner is piped as for a two pipe system up to the Oil De-aerator but only a single pipe is required to be run back to the oil storage tank.

A none-return valve is not required with this system but the bypass plug must be fitted in the pump as for a two pipe system.

The Oil De-aerator which should be fitted close to but not inside the boiler casing, is available from most Builders Merchants and some Oil Tank manufacturers.

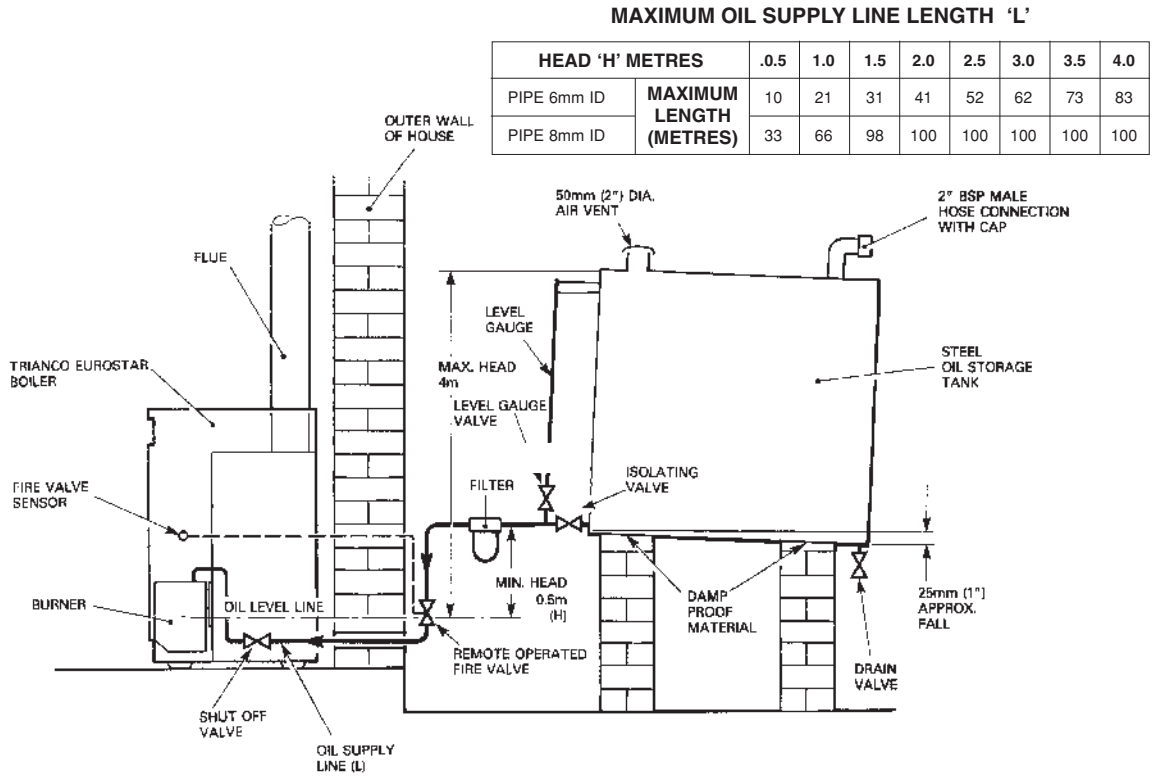

FIG. 6 SINGLE PIPE OIL SUPPLY INSTALLATION

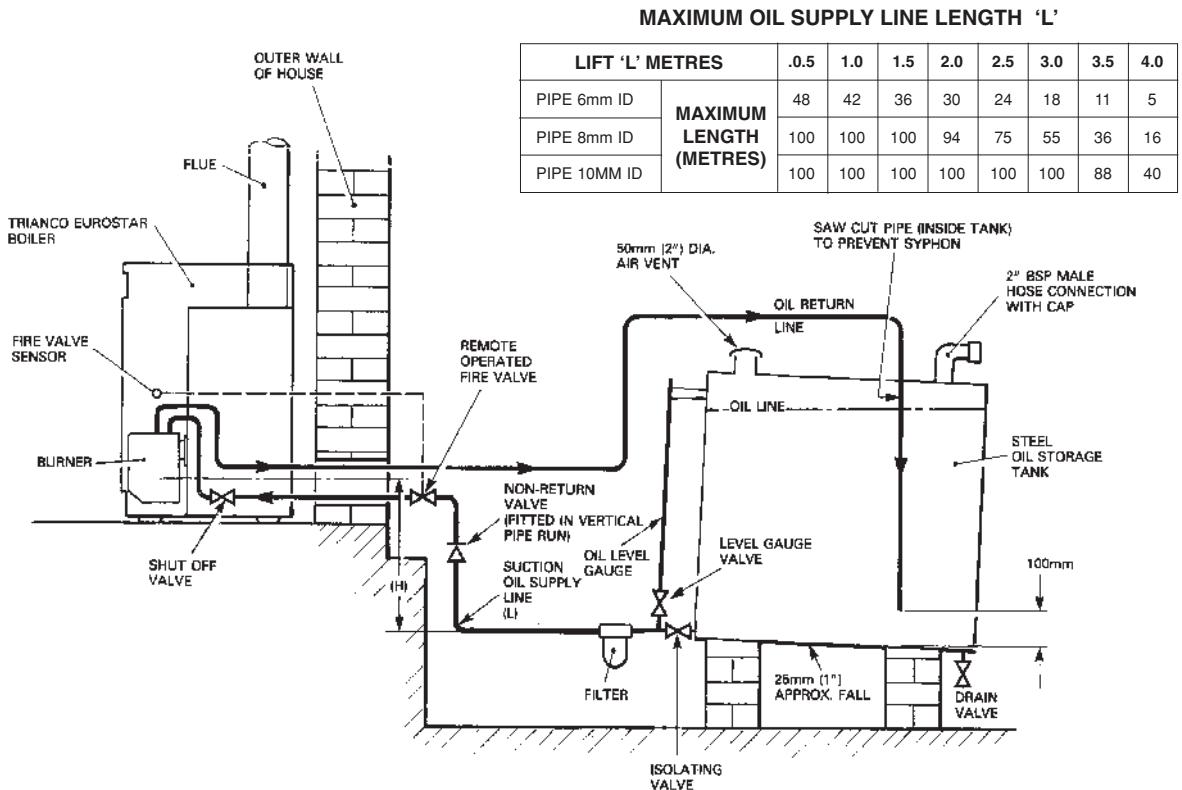

FIG. 7 TWO PIPE OIL SUPPLY INSTALLATION

REFER TO MANUFACTURERS
INSTRUCTIONS FOR 'OIL DE-AERATOR'
INSTALLATION DETAILS

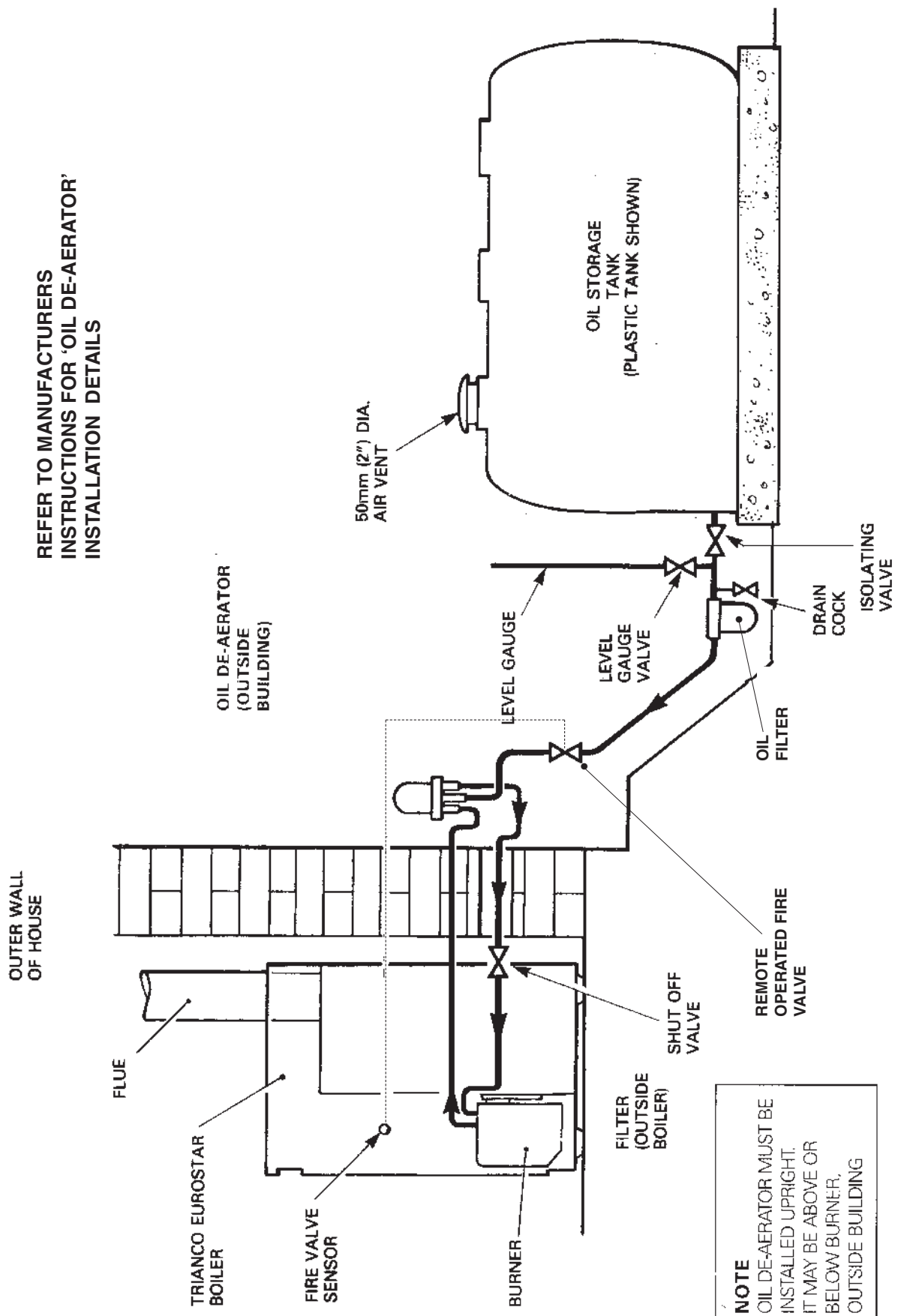

FIG. 8 DE-AERATED OIL SUPPLY INSTALLATION

6. FLUE SYSTEMS

To evacuate the products of combustion safely and thoroughly, the boiler must have an efficient flue system. The design and construction of the Trianco Low Level Discharger Kits already takes these factors into account so the following guidance notes are for conventional chimneys. Reference should also be made to BS 5410 Part 1 if further information is required on conventional chimneys.

Conventional chimney (Fig. 9)

- (a) The chimney should rise as vertically as possible and terminate at a point not subject to down draughts or wind eddies.
- (b) Brick and masonry chimneys must be lined with a moisture and acid resistant liner of the same diameter as boiler flue outlet.

The use of a flexible stainless steel liner is a convenient method of lining an existing chimney and this should be back filled with 'Vermiculite' or similar insulating material to retain heat.

A flexible liner should also be used in chimneys fitted with large diameter clay liners to reduce the flue bore and improve the thermal insulation.

Notes:

- (1) In view of the EuroStar's high thermal efficiency, it is important that a liner is fitted, otherwise condensation problems could result.
- (2) Before fitting a liner, the chimney must be thoroughly cleaned free from all traces of soot and scale.
- (c) A factory made insulated chimney complying with BS 4543 Part 3 may be considered as an alternative to a structural chimney both for new and existing buildings.
- (d) The in-built flue gas resistance of the EuroStar is such that it allows the boiler to operate reliably over the wide range of chimney draughts encountered from typical domestic chimneys.

The use of a draught-stabiliser should not be necessary nor is it desirable since it allows flue noise to be emitted into the room and it could cool the chimney condensing conditions.

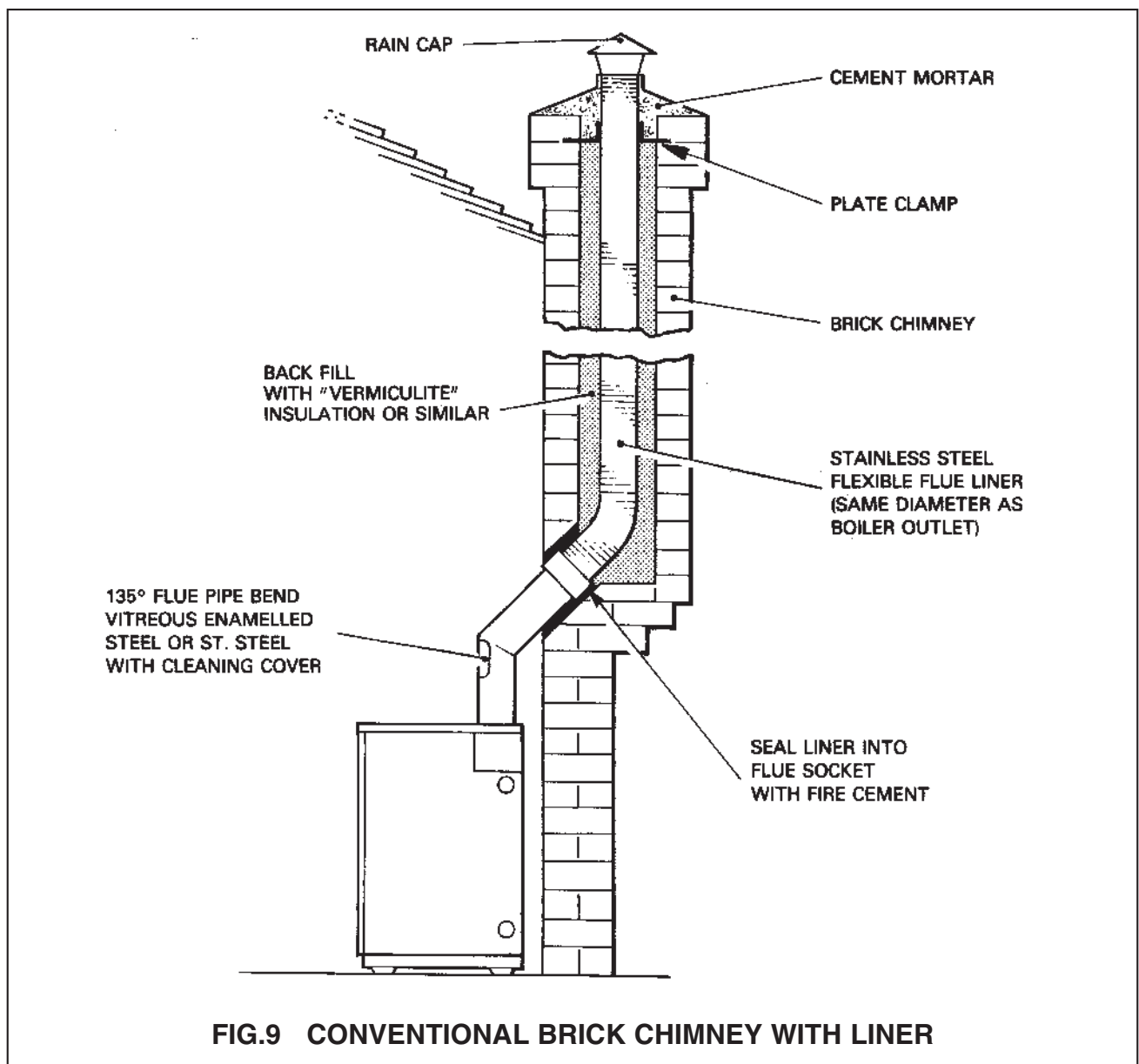

Balanced Flue Systems (optional extra)

The Trianco balanced flue system offers much greater flexibility for siting, the boiler compared with a conventional chimney. The only requirement is for a suitable outside wall to fit the horizontal discharge terminal or, alternatively, a single storey roof for a vertical discharge.

In addition to the siting benefit, the performance of balanced flue boilers is virtually unaffected by high wind conditions since the wind pressures are applied equally to both air intake and flue gas discharge, thus creating a balanced condition.

Whereas some balanced flue boilers rely on case sealing to achieve a room seal, Trianco boilers have a sealed air duct system which maintains the room sealed performance even when the casing door is removed for burner commissioning or adjustments.

The use of the balanced flue principle also enhances the overall thermal efficiency of the boiler since the incoming air extracts waste heat from the flue and returns it as pre-heated air to the burner where it aids combustion.

The high-level kits have an additional benefit in that the flue noise is reduced due to the coaxial arrangements of the air and flue pipes - the flue being surrounded by an air space forms an effective acoustic barrier.

INSTALLATION NOTES

(a) Location (Fig. 10)

Modern balanced flue boilers are designed to operate at low noise levels. However, when positioning your boiler, it is not recommended to have the terminal facing a neighbours property or patio etc. It should also be positioned to avoid products of combustion entering the building.

A distance of at least 600mm must be allowed between the terminal and any window, door or other opening into the building, (see diagram for recommended terminal positions).

(b) Flue Sealing

As the flue system operates under positive pressure, it is essential to seal all flue joints.

Apply a thin bead of silicone sealant (supplied) around flue pipe spigot before inserting into socket.

(c) Fuel

Only Kerosene 28 sec. Class C2 is permitted for boilers using low level flue discharge.

(d) Important

Trianco Flue Kits have been designed primarily to use with Trianco boilers and as such compatibility with other makes of boiler cannot be guaranteed.

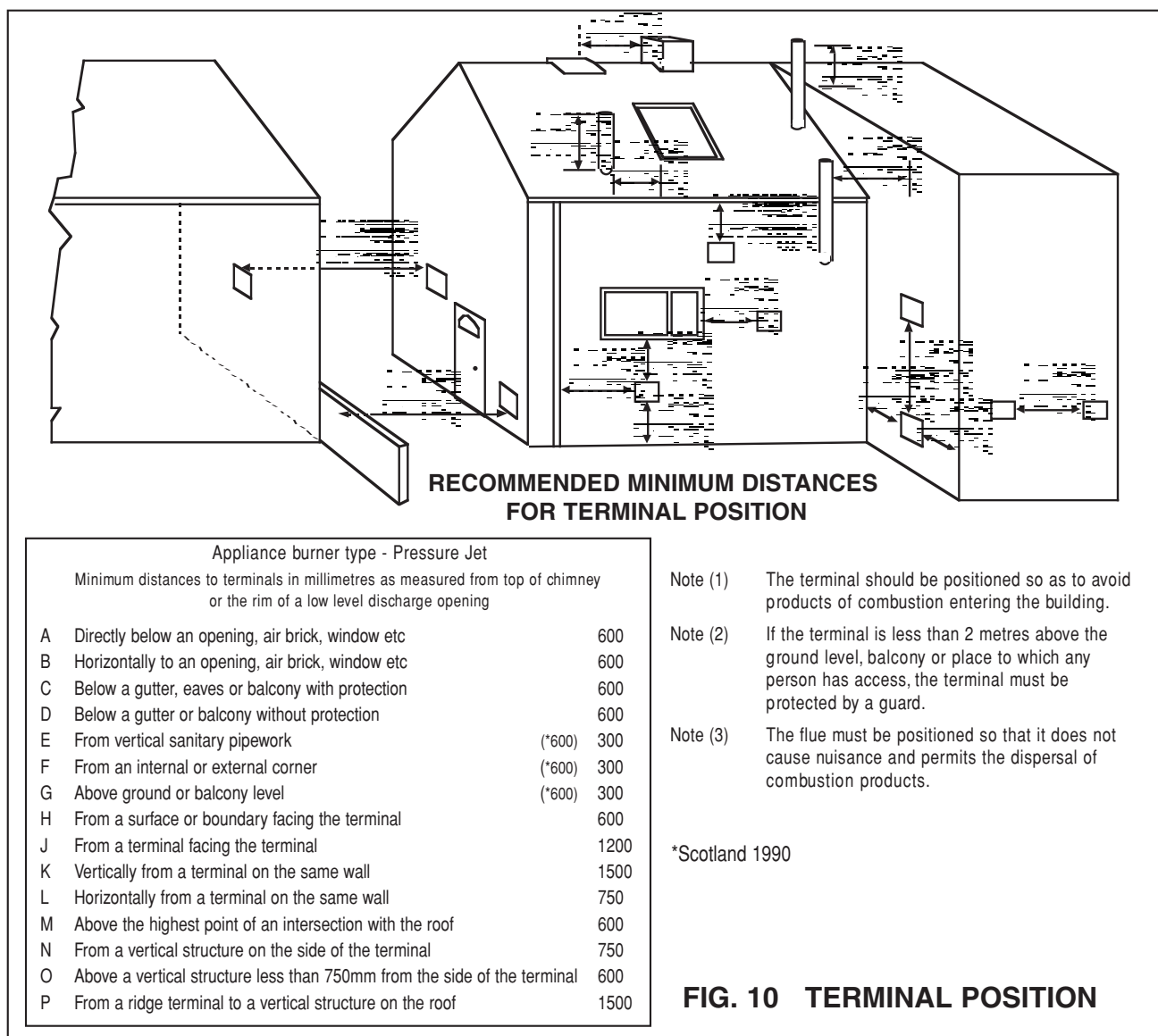

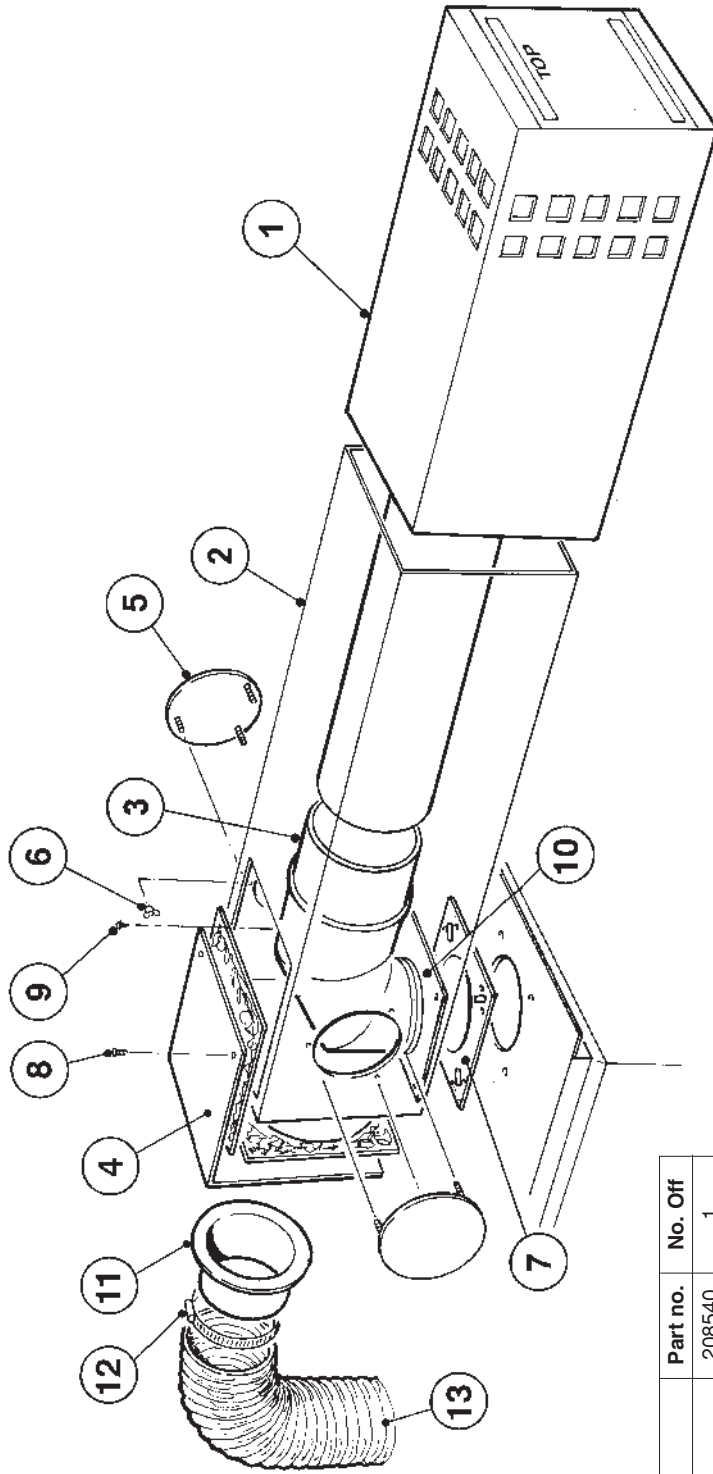

- 208575 on 2271 kit only
 - 221731 on 2271 kit only

Item	Description	Part no.	No. Off
1	Flue terminal	208540	1
2	Flue Box	208555	1
3	Flue elbow	208547	1
4	Blanking plate	208554	1
5	Round sealing plates	208551	3
6	M4 wing nut	94380	9
7	Blanking plate gasket	208559	3
8	No. 6 x 12mm STS Hex. HD	91601	2
9	No. 6 x 12mm STS Pozi. HD	91523	6
10	Inner flue pipe spigot plate	208566	1
11	Air hose spigot	206933	1
12	Clip	95256	1
13	Hose fitted on boiler	20693	1

Fig. 11

2270 600mm Horizontal Telescopic BF Kit

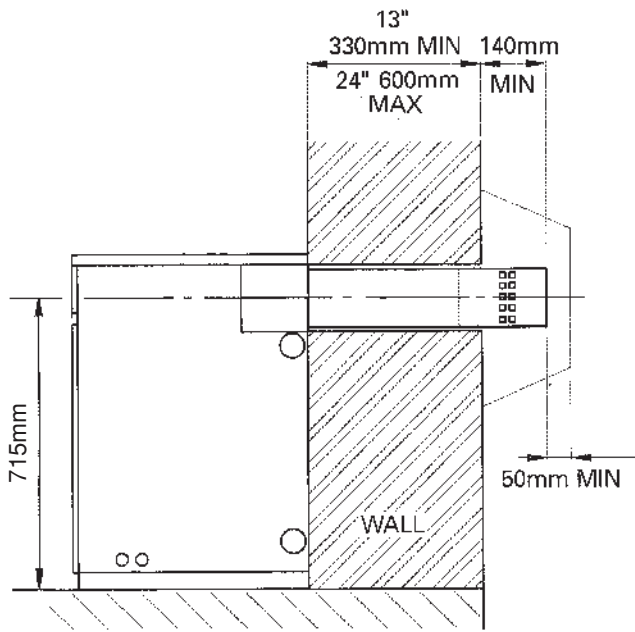

HOLE REQUIRED 170mm SQUARE
THROUGH WALL TO TAKE TERMINAL

REAR OUTLET

(Dimension 'A')
KIT 2270
MODEL 50/65
(8") 200mm MIN
(19") 480mm MAX

MODEL 70/90
(7") 175mm MIN
(18") 455mm MAX

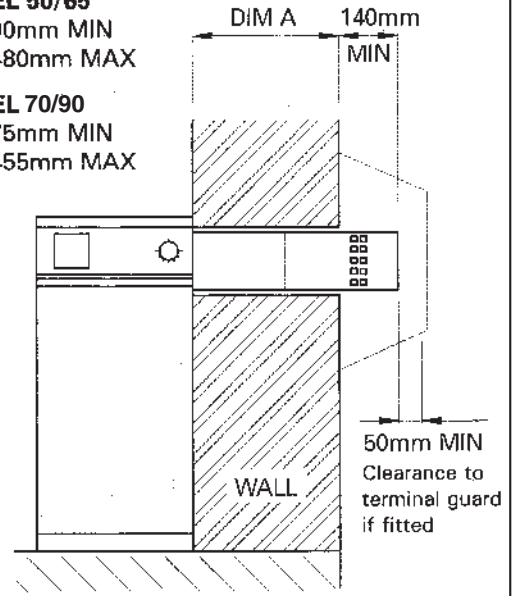

SIDE OUTLET

2271 1000mm Horizontal Telescopic BF Kit

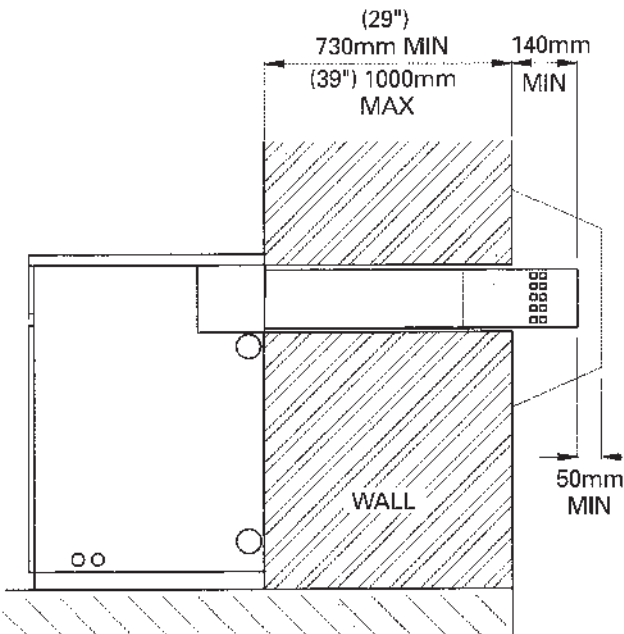

REAR OUTLET

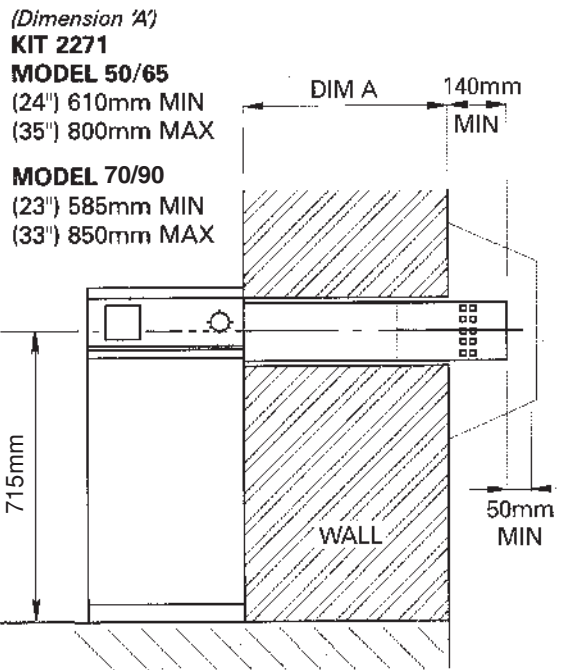

SIDE OUTLET

Fig. 12

**Trianco flue kits are designed to incorporate the latest 'O'-ring seals.
Before commencing assembly, please make sure that all 'O'-rings seals are in position.**

600mm HORIZONTAL TELESCOPIC BF KIT

ASSEMBLY METHOD (Fig 10/11)

1. Having decided the position of the boiler cut a hole 170mm square in the wall.
2. Remove the top casing and the flue socket from the top of the boiler. Ensure that the gasket is on top of the boiler and then place the white flue box on top of the gasket. Fit the stainless steel flue spigot plate into flue box and screw to the top of the boiler, trapping the gasket and box in position.
3. Fit the flue elbow to the stainless steel pipe on the terminal. Slide the terminal into the flue box from the outside and locate the elbow over the spigot plate.
4. Measure from the face of the outside wall to the end of the terminal. Subtract 140mm. This will give the length that requires cutting from the terminal inner pipe.
5. Remove the terminal from the flue box, remove the elbow from the pipe and then cut the terminal pipe to the required length. Replace the elbow in the end of the pipe and slide the terminal into the flue box, locating the elbow securely onto the spigot.
6. When terminating from the rear of the boiler, fit the air hose spigot over the hole in the L-shaped blanking plate, securing it with the M4 wing nuts provided. When terminating from the side of the boiler, fit the air hose spigot to the side of the flue box.
7. Fit the L-shaped blanking plate to the flue box. Blank off the remaining holes with the round sealing plates, using silicone sealant and the M4 wing nuts.
8. Fit the air hose between the burner and the spigot on the flue box, securing it using the clips provided.
9. Close any gaps around the terminal on both sides of the wall and replace the top casing.

TERMINAL GUARDS

When the terminal is positioned where there is the possibility of accidental contact by persons, or of damage to the terminal, an approved guard is necessary.

Generally, exhaust 2 metres above ground level alleviates the necessity for a guard.

A suitable guard is available from Trianco, part NO. 204123

1000mm HORIZONTAL TELESCOPIC BF KIT

ASSEMBLY METHOD (Fig 10/11)

1. Having decided the position of the boiler, cut a hole 170mm square in the wall.
2. Remove the top casing and the flue socket from the top of the boiler. Ensure that the gasket is on top of the boiler and then place the white flue box on top of the gasket. Fit the stainless steel flue spigot plate into the flue box and screw to the top of the boiler, trapping the gasket and box in position.
3. Fix the flue elbow to the stainless steel pipe on the terminal. Slide the terminal into the flue box from the outside and locate the elbow over the spigot plate.
4. Slide the terminal inwards over the elbow pipe until it is in the position required, making sure that there is a minimum distance of 140mm from the outside wall to the end of the terminal.
5. When terminating from the rear of the boiler, fit the air hose spigot over the hole in the L-shaped blanking plate, securing it with the M4 wing nuts provided. When terminating from the side of the boiler, fit the air hose spigot to the side of the flue box.
6. Fit the L-shaped blanking plate to the flue box. Blank off the remaining holes with round sealing plates, using silicone sealant and the M4 wing nuts.
7. Fit the air hose between the burner and the spigot on the flue box, securing it using the clips provided.
8. Close any gaps around the terminal on both sides of the wall and replace the top casing.

IMPORTANT: TO AID ASSEMBLY, IT IS NECESSARY TO APPLY A THIN BEAD OF LUBRICANT (E.G. WASHING - UP LIQUID OR VASELINE) TO ALL FLUE JOINTS THAT INCORPORATE 'O'-RING SEALS.

AS THE FLUE SYSTEM OPERATES UNDER POSITIVE PRESSURE, ALL FLUE JOINTS THAT DO NOT INCORPORATE 'O'-RING SEALS SHOULD BE SEALED WITH SILICONE SEALANT.

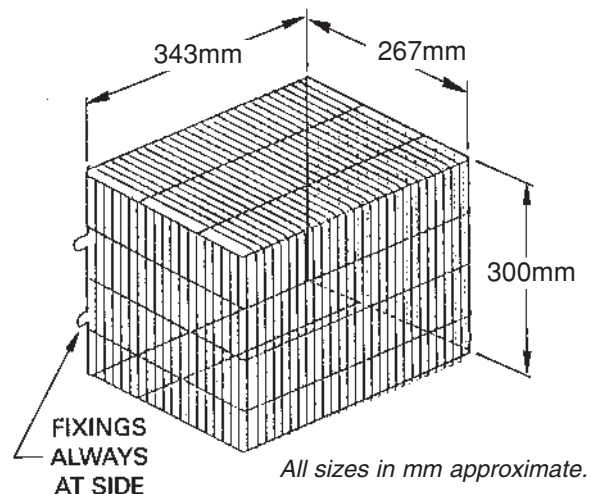

2272 HIGH LEVEL ADAPTOR KIT USED IN CONJUNCTION WITH 2270 OR 2271

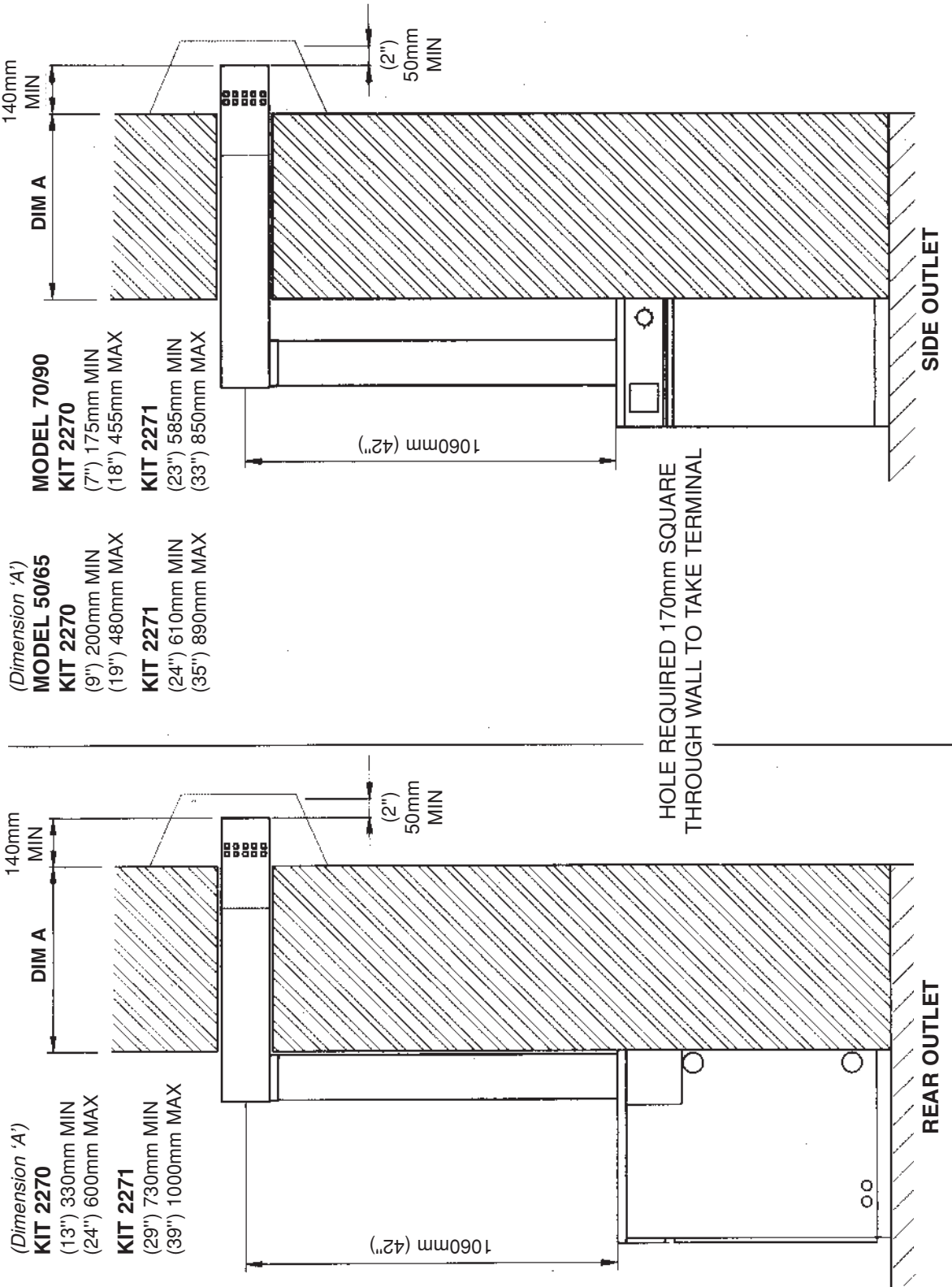

Fig. 13

Trianco flue kits are designed to incorporate the latest 'O'-ring seals. Before commencing assembly, please make sure that all 'O'-rings seals are in position.

ASSEMBLY METHOD (Fig 13/13a) - High Level Adaptor Kit used with 600mm Horizontal Telescopic BF

1. Having decided the position of the boiler, cut a 170mm square hole in the wall.
2. Take the collar piece and slide onto the top inner flue pipe (identified by *lack* of plate connection piece at base), making sure that the stop pieces are closest to the top of the collar. Line up the holes in the collar with the holes in the flue pipe and screw the collar into position using self-tapping screws.
3. Remove the top casing and remove the spigot plate from the top of the boiler. Place gasket on top of the boiler and then the inner flue pipe over the gasket. Use spigot plate (previously removed) as a clamping plate. Screw it down on top of the boiler, trapping the pipe and gasket in position.
4. Place outer lower pipe (identified by hose connection piece) over inner lower pipe (identified by flat spigot connection at base) and fit onto spigot plate.
5. Fit top inner flue pipe to lower flue pipe, using holes provided. Fit outer pipes together in same manner, making sure that top outer and inner pipes are level with each other.
6. Take the flue box and to the underside of the box (identified by twelve holes around the square cut out), fit the flue pipe spigot and gasket.
7. Slide the flue box through the cut out in the wall and locate outer flue pipe to the spigot on the flue box.
8. Fix flue elbow onto flue box inner pipe and slide terminal into the flue box from outside, locating elbow over collar piece.
9. Measure from the face of the outside wall to the end of the terminal and subtract 140mm. This will give the length of pipe to be cut off of the flue terminal inner pipe.
10. Remove the flue terminal from the flue box and remove the elbow. Cut the terminal inner pipe to the desired length and reassemble flue.
11. Fit round sealing plates in position on flue box using silicone sealant and M4 wing nuts.
12. Fit round sealing plates onto blanking plate and secure using four self-tapping screws.
13. Make good wall inside and outside.
14. Use clip provided to secure air hose from burner to connection on flue pipe.
15. Replace top casing.

ASSEMBLY METHOD (Fig 13/13a) - High Level Adaptor Kit used with 1000mm Horizontal Telescopic BF

1. Having decided the position of the boiler, cut a 170mm square hole in the wall.
2. Take the collar piece and slide onto the top inner flue pipe (identified by *lack* of plate connection piece at base), making sure that the stop pieces are closest to the top of the collar. Line up the holes in the collar with the holes in the flue pipe and screw the collar into position using self-tapping screws.
3. Remove the top casing and remove the spigot plate from the top of the boiler. Place gasket on top of the boiler and then the inner flue pipe over the gasket. Use spigot plate (previously removed) as a clamping plate. Screw it down on top of the boiler, trapping the pipe and gasket in position.
4. Place outer lower pipe (identified by hose connection piece) over inner lower pipe (identified by flat spigot connection at base) and fit onto spigot plate.
5. Fit top inner flue pipe to lower flue pipe, using holes provided. Fit outer pipes together in same manner, making sure that top outer and inner pipes are level with each other.
6. Take the flue box and to the underside of the box (identified by twelve holes around the square cut out), fit the flue pipe spigot and gasket.
7. Slide the flue box through the cut out in the wall and locate outer flue pipe to the spigot on the flue box.
8. Slide telescopic inner flue pipe over inner flue pipe of flue terminal. Fix flue elbow onto end of telescopic inner pipe and slide terminal into the flue box from outside, locating elbow over collar piece.
9. Push terminal inwards. A minimum dimension of 140mm from the wall to the end of the terminal is required.
10. Fit round sealing plates in position on flue box using silicone sealant and M4 wing nuts.
11. Fit round sealing plates onto blanking plate and secure using four self-tapping screws.
12. Make good wall inside and outside.
13. Use clip provided to secure air hose from burner to connection on flue pipe.
14. Replace top casing.

Supplied with the kit are two spigots. Use the spigot that does *not* have chamfered corners. The other spigot is not required for this installation. Each vertical section of pipe has a different diameter. The lowermost pipes have the smallest diameter, the uppermost the largest.

To aid assembly, it is necessary to apply a thin bead of lubricant (e.g. washing up liquid or Vaseline) to all flue joints that incorporate 'O'-ring seals. As the flue system operates under positive pressure, all flue joints that *do not* incorporate 'O'-ring seals should be sealed with silicone sealant.

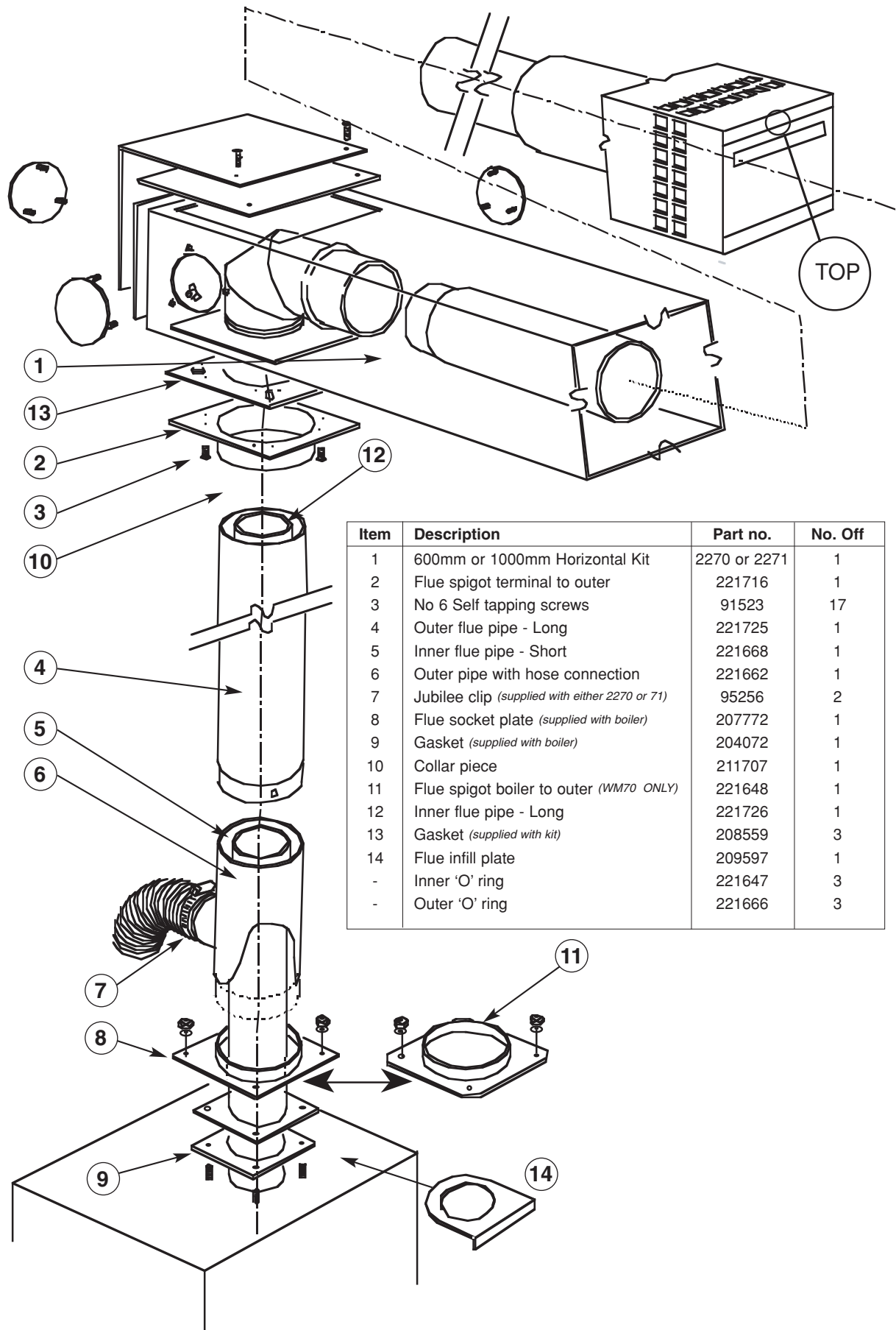

Fig. 13a 2272 UNIVERSAL HIGH LEVEL BF ADAPTOR KIT

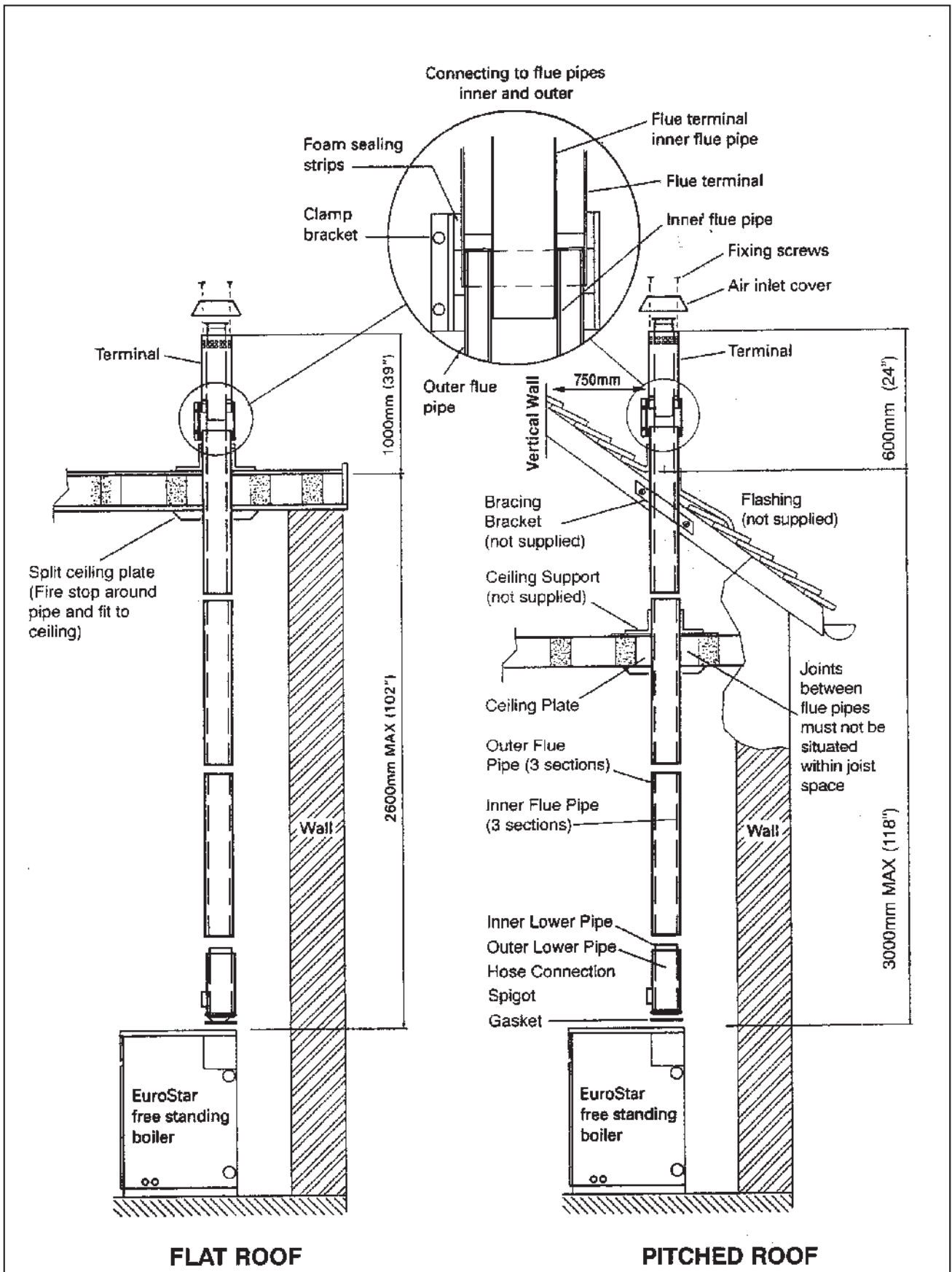

Fig. 14 2273 VERTICAL BALANCED FLUE KIT

Vertical Balanced Flue Kit

The vertical balanced flue kit is designed to be telescopic in nature and incorporates the latest 'O'ring seals. It is therefore unnecessary for any 'cutting down' of pieces to the required size.

Please note that to facilitate the connection process, each section of pipe has a different diameter. The lowermost pipes have the smallest diameter, the size increasing with each subsequent section of pipe. The lowermost pipes are also the shortest, with the subsequent inner and outer sections being the next shortest. The next sections are all the same length, however the highest inner and outer pipes have a single hole at the top above the 'O' ring seal. Before commencing the assembly process, please make sure that you have correctly identified the placement of each pipe section and that all 'O' ring seals are in position.

ASSEMBLY METHOD (Fig.14/14a)

1. Having secured the boiler in position cut a hole 175mm diameter or square in the ceiling and roof.
2. Remove top casing of boiler and remove the flue socket from the top of the boiler body.
3. Determine the flue length required, ensuring that the top outer flue pipe will finish above the roof flashing line. If possible, pre-assemble the entire flue on a flat surface. Use the pre drilled holes at the base of each pipe to drill 2.8mm diameter holes near the top of each pipe for use with the self-tapping screws.

Note: The lowermost inner pipe will protrude from the top of the lowermost outer pipe by approximately 40mm to ensure easy accessibility when fixing the inner pipes together. The bottom sections already have pre-drilled holes, located near to the top of the pipes.

The flue spigot plate must fit over the inner lower pipe before the outer lower pipe is put in position.

The flue infill plate is placed on the top casing (once replaced), however it should be fitted around the outer pipe before the full flue is assembled.

4. If possible to do so, lift the entire assembled flue through the ceiling and secure in position on top of the boiler. Fasten down with existing nuts and washers.

5. If this is not possible, then fit the flue piece by piece, being aware that none of the flue joints should be situated within the joist space.

Note: The air inlet holes on the terminal must not be blocked on the outside, or on the inside by the upper flue pipe.

6. Fit ceiling plate centrally over hole, ensuring that the outer flue pipe has a minimum clearance of 25mm from any combustible material. Pack space with glass fibre insulation.
7. Fix pipe bracket (where necessary) to roof space and fit waterproof flashing (not supplied) around outer flue pipe at roof line.
8. Fit clamping strap (supplied) around joint line of terminal and upper flue pipe. Use foam sealing strip inside clamping strap.
9. Fit the apron cravat (air inlet cover) to the terminal using 4 self-tapping screws (supplied).
10. Use clip provided to secure air hose from burner to connection on the outer lower pipe.
11. Replace top casing.

IMPORTANT: FLUE SEALING

TO FIT FLUE PIPES TOGETHER THAT INCORPORATE 'O' RING SEALS, IT IS ESSENTIAL TO APPLY A THIN BEAD OF LUBRICANT (E.G. WASHING UP LIQUID, VASELINE) AROUND ALL RUBBER SEALING RINGS.

AS THE FLUE SYSTEM OPERATES UNDER POSITIVE PRESSURE, IT IS ESSENTIAL TO ACHIEVE A TOTAL SEAL ON FLUE JOINTS. APPLY A THIN BEAD OF SILICONE SEALANT AROUND THE BASE OF FLUE PIPE BEFORE INSERTING INTO BOILER SPIGOT.

EXPOSED PIPE:

ANY PIPE EXPOSED TO THE ELEMENTS SHOULD BE PROTECTED WITH A SUITABLE MATERIAL. WHEN ASSEMBLING THIS KIT, PLACE ALL WELD SEAMS TO THE REAR.

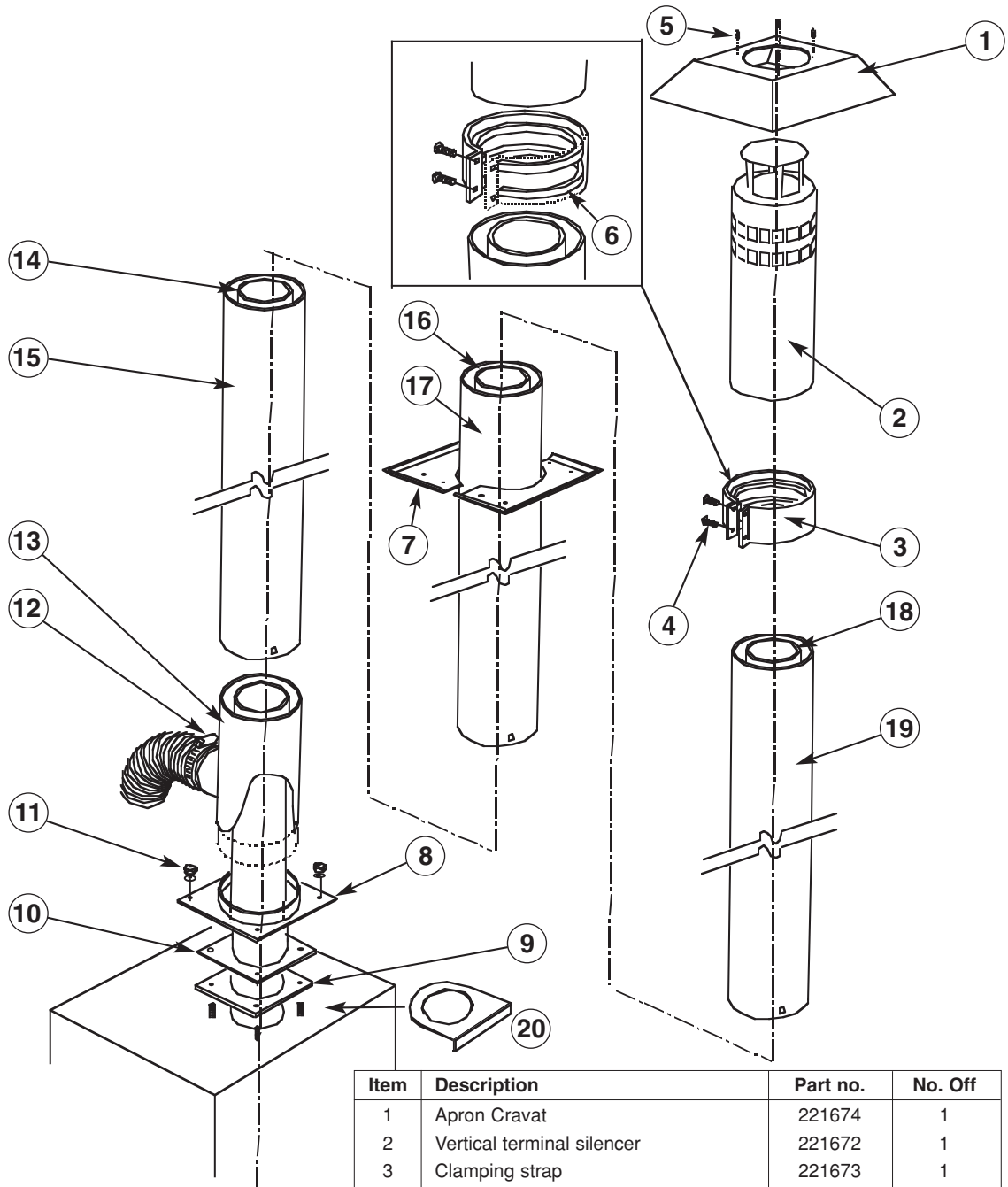

Fig. 14a
2273 UNIVERSAL VERTICAL
BALANCED FLUE KIT

Item	Description	Part no.	No. Off
1	Apron Cravat	221674	1
2	Vertical terminal silencer	221672	1
3	Clamping strap	221673	1
4	M4 x 35 Pan head Pozi	-	4
5	No. 8 Self tapping screw	-	4
6	Silicone sponge	98112	2pcs
7	Ceiling plate half	208583	2
8	{ Flue socket plate (supplied with boiler)	207772	1
	{ Flue socket plate (WH70 only)	221648	1
9	Gasket (supplied with boiler)	204072	1
10	Inner pipe bottom lower section	221668	1
11	M6 nuts & washers	-	4
12	Jubilee clip	95256	2
13	Outer flue pipe with hose connection	221662	1
14	Inner pipe lower section	221726	1
15	Outer pipe lower section	221725	1
16	Inner pipe middle section	221669	1
17	Outer pipe middle section	221665	1
18	Inner pipe top section	221670	1
19	Outer pipe top section	221667	1
20	Flue infill plate	209597	1
-	Inner 'O' ring	221647	4
-	Outer 'O' ring	221666	4

7. COMMISSIONING

It is strongly recommended that the boiler/burner unit is commissioned by a qualified technician, preferably OFTEC trained and registered.

It is the responsibility of the installer to ensure the boiler is properly commissioned, failure to do so will make the boiler's guarantee and any extended warranty null and void.

Although all burners are factory tested before despatch, they will usually need further air adjustment to achieve the readings indicated in 'Burner detail leaflet' because of site variations in flue draught and back pressure.

Procedure

1. Switch off electrical supply to the boiler.
2. Ensure boiler is full of water and all valves are open.
3. Remove flue-cover and check that flue-baffles are correctly positioned (See Fig 15 for baffle arrangement).
4. Disconnect oil hose from burner, open shut-off valve and run off a quantity of oil into a container to check for a clean air free supply then reconnect hose. (This applies to single pipe gravity system only).
5. Check that the time-switch (if fitted) is in the ON position and room and boiler thermostats are calling for heat.
6. Switch on electrical supply and the burner should start.

Note: The burner may lock-out on first firing due to air in the pump, if this happens, wait about a minute before pressing reset button to restart burner. If a further lock-out occurs, the air should be bled from the pump pressure gauge connection.

IMPORTANT: ENSURE THAT THE OPEN END OF THE AIR INTAKE HOSE IS NOT OBSTRUCTED

7. Start and stop the burner two or three times until the flame cuts off sharply - this indicates any remaining air has been dispersed.
8. Allow the burner to run for about 15 minutes, then take a CO₂ reading through the sampling hole in flue-cover. Compare the reading with that given under 'Burner Settings' and adjust the air setting if necessary to achieve the required CO₂%. Also, check the smoke and flue gas temperature.

Handing Over

After completing the boiler installation, the installer should make a thorough check of the system to ensure it is completely satisfactory and demonstrate to the user the operation of the boiler and any system controls.

All instructions should be handed to the user for retention and advice regarding the need for annual servicing.

8. SERVICING

IMPORTANT: ISOLATE ELECTRICAL SUPPLY TO THE BOILER BEFORE SERVICING

To maintain the boiler's high thermal efficiency and reliable operation, it should be serviced annually by a qualified engineer preferably OFTEC trained and registered. Electrical work should be carried out by a qualified engineer.

If the boiler is used to provide central heating and hot water all year round, the best time for its annual service is just before the start of the heating season.

Where the boiler is shut down for the summer months, the service should be carried out as soon as possible after the end of the heating season.

Oil tank

Open tank drain-cock to draw off any accumulated water and sludge.

Line filters

Turn off oil supply and remove filter bowl. Wash filter element clean with kerosene.

Servicing the Boiler (Burner removed)

1. Remove flue-cover and lift out flue-baffles (See Fig. 15).
2. Brush all deposits from flue-baffles and internal surfaces of the boiler.
3. Remove flue deposits from the combustion chamber floor using a vacuum cleaner.
4. Replace flue-baffles in the correct arrangement (See Fig. 15 for order of assembly). Refit the flue-cover and fully tighten wing-nuts to make a gas tight seal.
5. Refit burner to boiler, connect flexible air hose (balanced flue boilers only) and plug-in burner lead.
6. Turn on oil supply, switch on electricity and burner should fire.
7. Finally check the combustion readings with those given under 'Burner Settings' and make any air or oil pressure adjustments necessary.

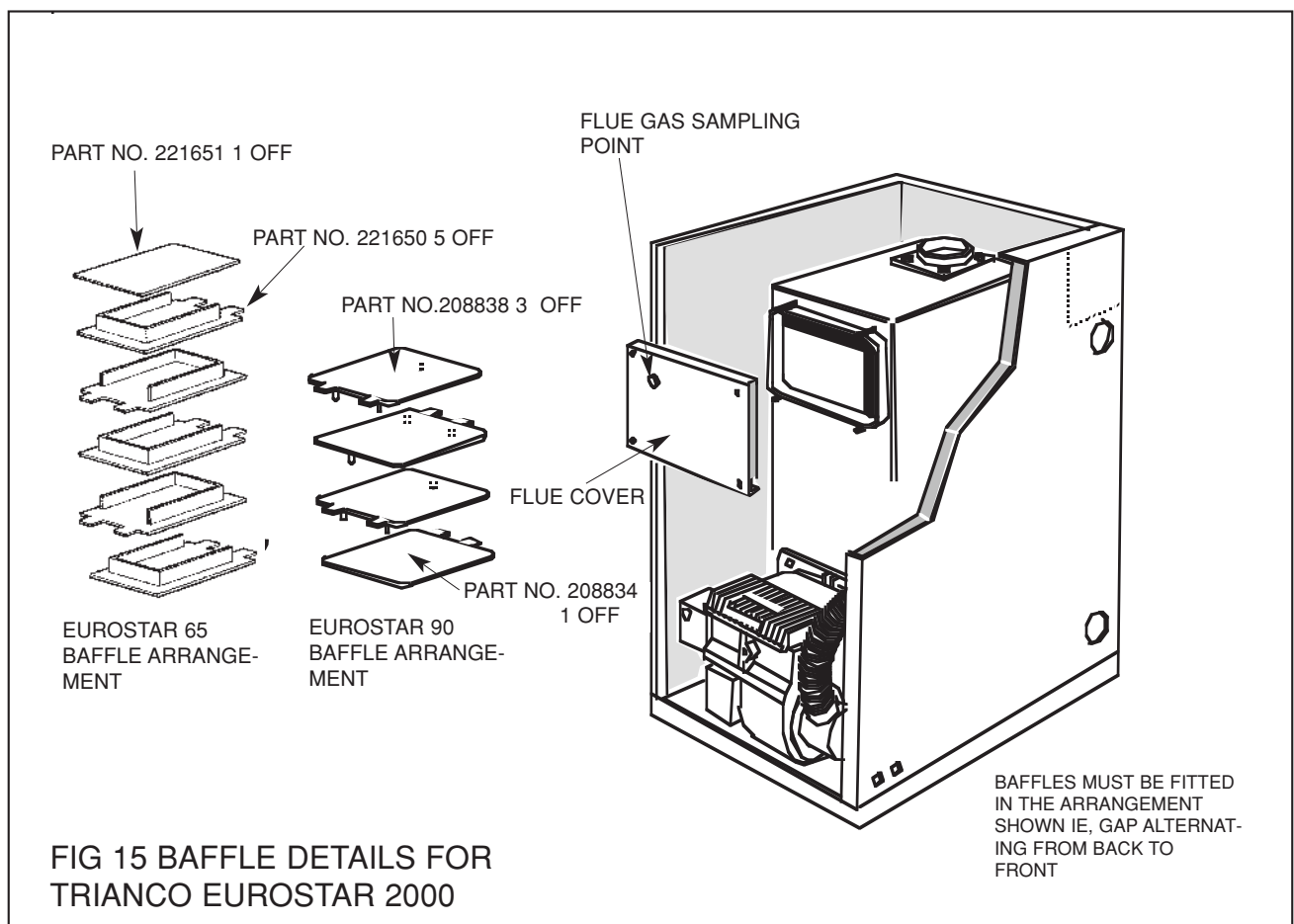

9. FAULT FINDING

ELECTRICITY SAFETY - Before making any electrical checks, switch off mains supply to boiler.

FAULT	POSSIBLE CAUSE	ACTION
BURNER WILL NOT START (see separate burner leaflet)	Control box locked out	Press reset button on front of burner. N.B. ONLY TRY TWICE
	Limit-stat tripped	Press reset button under control panel and check function of boiler control thermostat.
	Boiler thermostat or other system controls satisfied	Ensure all controls are calling for heat.
	Fuse blown	Fit new 5 amp fuse, if it blows again, check for short circuit in wiring.
	Check for live supply continuity up to burner	If live supply confirmed, change control box
	Motor or pump seized	Check for rotation and replace as necessary.
BURNER STARTS BUT FLAME NOT ESTABLISHED	No oil supply	Check oil level in tank and feed to burner.
	Photo-cell not seeing flame	Clean photo-cell and ensure it is fully plugged in.
	Air trapped in pump	Bleed off air through pressure gauge tapping.
	Solenoid valve faulty	Check coil for continuity and replace if faulty.
	Nozzle blocked	Replace nozzle with one of same specification.
	Electrodes incorrectly set	Reset gap and position electrodes as shown in Burner diagram.
	Electrode insulator cracked	Check and replace if insulator cracked or crazed.
	Ignition transformer and H.T. contacts	Check for spark and condition of H.T. contacts. Replace as necessary.
	Low oil pressure	Check pump pressure and adjust to correct setting.
FLAME ESTABLISHED BUT BURNER LOCKS OUT AFTER FEW SECONDS	Oil contaminated with water	Run off oil at burner until free of water and drain condensation from tank
	Oil filter partially blocked	Wash filter clean with kerosene.
	Photo-cell fault	Clean photo-cell and ensure it is fully plugged in. Replace if faulty.
	Oil pressure low	Check pump pressure and adjust to correct setting.

FAULT FINDING (Cont'd)

FAULT	POSSIBLE CAUSE	ACTION
POOR FLAME CUT-OFF	Air in pump or at back of nozzle	Bleed pump through pressure gauge port, also check for leaks in oil line if 2-pipe system.
	Oil contaminated with water	Run off oil at burner until free of water and drain condensation from tank.
	Dirt in solenoid valve	Clean or replace valve.
	Pump shut-off piston sticking	Replace pump.
MORNING START LOCK-OUT	Faulty non-return valve or air leak in two pipe system	Replace non-return valve and cure leak.
	Low voltage	Check with local Electricity Board.
	Combustion readings incorrect	Check combustion under normal running conditions and compare readings with those given under 'Burner Settings'.
	Oil level in tank falling below burner	Raise tank or fit a 2-pipe system.

10. SPARES

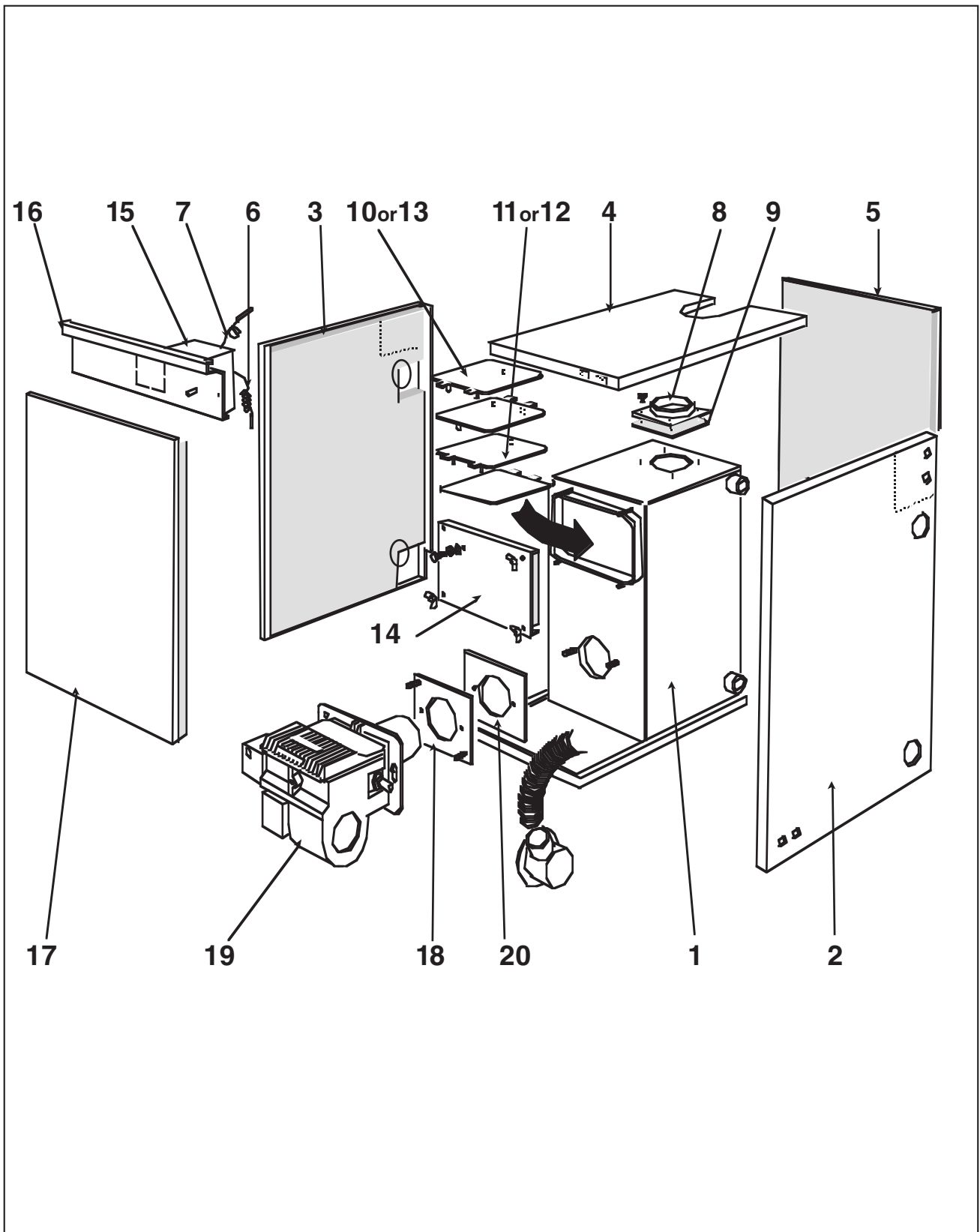

FIG. 16 EuroStar 2000 50/65 & 70/90 BOILER EXPLODED VIEW

EuroStar Boiler Parts

Item	Description	No. Off	50/65	70/90	
1	Boiler Body	1	211229	211230	
2	R/H Side Panel Assembly	1	221135	221135	
3	L/H Side Panel Assembly	1	221134	221134	
4	Top Panel Assembly	1	221137	221139	
5	Back Panel	1	221143	221178	
6	Boiler Control Thermostat	1	206896	206896	
7	Limit Thermostat	1	206892	206892	
8	Flue Socket Plate	1	207772	207772	
9	Gasket	1	204072	204072	
10	Top Baffle W.U	1	221651	-	
11	Bottom Baffle W.U	5	221650	-	
12	Bottom Baffle W.U	1	-	208834	
13	Top Baffle W.U	3	-	208838	
14	Flue Cover Assembly		208780	208804	
15	Control Box Back Assembly	1	221180	221180	
16	Control Box Front Assembly	1	221127	221118	
17	Door Assembly	1	221136	221138	
18	Burner MTG flange	1	221161	-	
19	Burner Assembly	1	221300	221380	
20	Gasket	1	221173	221173	



By appointment to H.M. Queen Elizabeth
The Queen Mother
Manufacturers of Domestic Boilers



TRIANCO LIMITED
Thorncliffe, Chapeltown, Sheffield S35 2PH
Tel: Sheffield (0114) 257 2300
Fax: (0114) 257 1419
www.trianco.co.uk



© Trianco Limited, Copyright in this brochure and the drawings or illustrations contained in it is vested in Trianco Limited and neither the brochure or any part thereof may be reproduced without prior written consent.

Trianco policy is one of continuous research and development. This may necessitate alterations to this specification.