



TRIANCO

**Aztec Mini
Combination & System Boiler**



**INSTALLATION, OPERATION AND
SERVICING INSTRUCTIONS**

**Please read these instructions carefully before installing
and operating this appliance
TO BE RETAINED BY HOUSEHOLDER**

CONTENTS	PAGE
HEALTH AND SAFETY	3
PRE-INSTALLATION NOTES	4
AFTER SALES SERVICE	5
IMPORTANT SAFETY NOTES	6
USER INSTRUCTIONS	7/8
FAULT FINDING	9
INSTALLATION - REGULATIONS	10
INSTALLATION – CLEARANCES & VENTILATION	11
INSTALLATION – WATER SYSTEM	12
INSTALLATION – EXPANSION VESSEL SIZING	13
INSTALLATION	14
INSTALLATION – PIPEWORK LAYOUT	15
INSTALLATION – WIRING	16
INSTALLATION – EXTERNAL CONTROLS	17
INSTALLATION – PUMP SETTINGS	18/19
INSTALLATION – TECHNICAL DETAILS COMBI	20
INSTALLATION – TECHNICAL DETAILS SYSTEM	21
BOILER SPARES	22/23
COMMISSIONING REPORT	24

HEALTH AND SAFETY

INFORMATION FOR THE USER, INSTALLER AND SERVICE ENGINEER

Under the Consumer Protection Act 1987 and the Health and Safety at Work Act 1974, it is a requirement to provide information on substances hazardous to health (COSHH Regulations 1998).

TR Engineering takes every reasonable care to ensure that its products are designed and constructed to meet these safety requirements when the products are properly installed and used. To fulfil the requirements, products are comprehensively tested and examined before despatch.

When working on the appliance, it is the responsibility of the user or engineer to ensure that personal protective clothing or equipment appropriate to parts that could be considered hazardous or harmful is worn.

This appliance may contain some of the items below:

Insulation and Seals

Glass rope, mineral wool, insulation pads, ceramic fibre and glass insulation.

When handling, avoid inhalation and contact with eyes. These may be harmful and cause irritation to the skin, eyes, nose or throat. Use disposable gloves, facemasks and eye protection.

After handling, wash hands and other exposed areas. When disposing of materials, limit dust and the risk of inhalation by using water spray. Ensure materials are securely wrapped.

Seek urgent medical attention if inhaled or ingested. Exposure to eyes and skin should be followed by immediate cleansing of the affected areas and medical attention if necessary.

Glues, Sealants and Paints

The glues, sealants and paints used present no known hazards when the appliance is used in the manner for which it is intended.

Notes:

- a) Electrical safety checks should be carried out by a competent person.
- b) It is a requirement of the guarantee and any extended warranty that an annual service is carried out by a competent person.

Installation Engineers Signature

Company Name (if applicable)

Company Address

Company Tel. No.

Please read these instructions fully before installing this appliance.

These instructions should be kept in a place close to the appliance for easy reference.

IMPORTANT PRE-INSTALLATION NOTES

By Fitting this Aztec Mini boiler, you agree:

- **The Boiler has been received in good condition.**
- **You have carried out a heat loss calculation and are sure that this boiler is suitable.**
- **If fitting the combination boiler, you have checked that the hot water flow rate is sufficient for the application.**
- **You have carried out a load and voltage test to determine the correct size of breaker to be used.**

Before installation, it is imperative that the following guidelines are heeded to ensure the trouble-free and efficient operation of the boiler:

Ventilation and Siting

When siting the boiler in a confined space it is essential that adequate ventilation be provided. This will ensure that air can circulate freely around the appliance keeping down the ambient temperatures. Refer to Ventilation requirements (Page 11) for further details.

Ensure that the area surrounding the boiler is kept free of items which would impede the good ventilation of the appliance (e.g., towels, linen, etc).

When siting the boiler, consider the potential requirement for future servicing. Enough space should be provided at the front of the boiler to enable an engineer to adequately service and/or replace items such as the PCB or heat exchanger. Space should also be available for the removal of the front casing panel. Please refer to siting information (Page 11) for clearance dimensions. The boiler must be sited vertically and away from strong magnetic fields.

Power Supply and Wiring

The power supply to the premises must meet the minimum requirements of the unit being installed, with special attention paid to the supply current, cable size, and RCD recommendation. The supply voltage to the appliance must never drop below **207 Volts**.

System

Isolation valves must be fitted on both the flow and return pipe work. These are useful as from time to time the boiler may require draining of water, and the lengthy drawing-off process can be avoided by the astute placement of these valves. Ensure that any isolation valves are open before first use, and that the system is full of water.

IMPORTANT:

General Information:

To keep your boiler running efficiently **DO NOT OBSTRUCT OR COVER** any ventilation air inlet on the appliance or the compartment where it is installed.

To keep the casing clean, switch 'OFF' the boiler at the electrical supply, and simply wipe with a damp cloth. **DO NOT** use abrasive cleaning fluids as this may damage the stove enamel paintwork.

TR ENGINEERING LTD CUSTOMER AFTER SALES SERVICE INFORMATION

The boiler comes with a 5 Year warranty, providing the boiler is registered within 30 days from the date of installation. Register online at: www.trianco.co.uk/product-registration

Terms and Conditions apply, please see Trianco web site for details.

Please note you will require the full boiler serial number to be able to register the boiler. The serial number is located on the right-hand side of the boiler and can also be found on the box the boiler came in.

A step-by-step guide to reporting a fault with your appliance.

A qualified field SERVICE ENGINEER is available to attend a breakdown or manufacturing fault occurring whilst the appliance is under warranty.

The appliance must be made available for service during normal working hours, Monday to Friday (no weekend work or bank holidays accepted).

A charge will be made where:

- Our Field Service Engineer finds no fault with the appliance.
- The cause of a breakdown is due to other parts of the plumbing/heating system or with equipment not supplied by TR Engineering Ltd.
- Where the appliance falls outside the warranty period (see terms and conditions enclosed).
- The appliance has not been correctly installed, as recommended (see installation, operating and servicing instructions.)

NOTE: Over 50% of all service calls made are found to have no appliance fault.

What to do in the event of an appliance fault or breakdown:

Step 1: Always contact your installer in the first instance, who must thoroughly check all his work PRIOR to requesting a service visit from TR Engineering LTD.

Step 2: If your appliance has developed an in-warranty fault your installer should contact TR Engineering LTD for assistance from site.

What happens if my Installer/engineer is unavailable?

Step 3: Contact TR Engineering LTD. We will provide you with the name and telephone number of our Service Agent. However, a charge may apply if the fault is not covered by the appliance warranty (payment will be requested on site by our independent Service Agent).

PLEASE NOTE: UNAUTHORISED INVOICES FOR ATTENDANCE AND REPAIR WORK CARRIED OUT ON THIS APPLIANCE BY ANY THIRD PARTY WILL NOT BE ACCEPTED BY TR ENGINEERING LTD

SERVICE CENTRE AND TECHNICAL SUPPORT

Tel: 0114 257 2300 Fax: 0114 257 1419

Hours of Business

Monday to Thursday 8.30am - 5pm

Friday 8.30am - 2.30pm

IMPORTANT SAFETY NOTES

INTRODUCTION

The Aztec Mini Electric Combination and System Boiler is a wall mounted electric central heating boiler designed with smaller properties in mind. Access is required to the front of the boiler for servicing. Once the boiler is switched on it is fully controlled by an automatic management system which monitors the safety and running functions of the boiler. Designed to work on a fully pumped wet system only. The boiler produces hot water by passing water over electric heating elements housed in an insulated heat exchanger.

The boilers incorporate inverter constant temperature technology which automatically adjusts output to match demand.

Read these instructions before installing your boiler.

1. Always switch OFF the electrical supply before removing the cover.
2. If any part of the boiler is modified, then the warranty will be invalidated.

We recommend that you keep these instructions in a place near your appliance for easy reference.

The Trianco Aztec Mini Combination and System Wall Mounted Boiler has been designed to conform to European Directive/Standards EN60335-1:2002 +A15:2011, EN60335-2-35:2002 inc Amd 1, EN55014-1:2006 +A1:2009, EN55014-2:1997 +A2:2008.

THE PERSON(S) WHO INSTALLS THIS APPLIANCE, SERVICES OR CARRIES OUT ANY REMEDIAL WORK, I.E. ELECTRICAL FAULT FINDING, MUST HAVE SUITABLE ENGINEERING QUALIFICATIONS.

WARNING: DO NOT SWITCH ON THIS APPLIANCE IF THERE IS ANY POSSIBILITY THAT THE WATER MAY BE FROZEN.

THE INSTALLATION OF THIS APPLIANCE MUST MEET THE REQUIREMENTS OF THE CURRENT ISSUE FOR ELECTRICAL INSTALLATIONS IEE WIRING.

USER INSTRUCTIONS

The Trianco Aztec Combination boiler has been designed and constructed to give years of trouble-free service and these instructions are provided to assist you in obtaining the best performance with the least trouble and cost.

The boiler is fully automatic in operation and requires little attention other than the setting of the thermostat and any external system controls such as a room thermostat.

This appliance is not intended for use by anyone (including children) with reduced physical or mental capacities, or lack of experience with the appliance, unless they have been given instruction by a competent person responsible for their safety.

IMPORTANT

DO NOT COVER OR BOX IN YOUR BOILER WITHOUT MAKING SUITABLE PROVISION TO ALLOW AIR TO CIRCULATE FREELY AROUND THE APPLIANCE

WARNING: DO NOT ATTEMPT TO SWITCH ON THE BOILER IF THERE IS ANY POSSIBILITY THAT THE WATER INSIDE THE HEAT EXCHANGER IS FROZEN

Before turning the boiler on, ensure the system is full of water and all valves fitted to the system are open.

Switch on the power supply, display will illuminate. Observe any error codes – Refer to table on Page 9.

Boiler Multi-Function Display

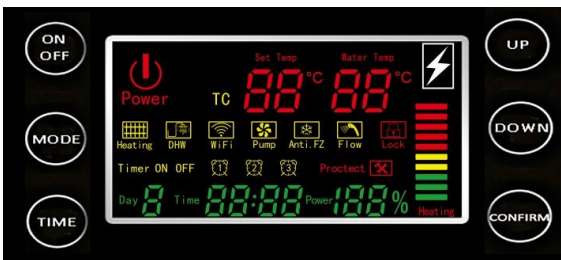

Press ON/OFF button to turn boiler on – Standby

In Standby Mode

Set temperature, outlet temperature, room temperature control and time are illuminated.

Setting Boiler Thermostat

Press the UP/Down key to adjust temperature. 30°C - 80°C Press the confirm key to save.

Heating return difference Temperature setting

In standby press the mode key once, screen shows CH, press UP/DOWN key to choose temperature between 5°C - 30°C Press Confirm to save.

Setting Domestic Hot Water (DHW) Temperature. **Combination Boiler Only**

Turn on the DHW tap. DHW illuminates on display. Press UP/DOWN key to set temperature. 30°C - 60°C Press Confirm to save. In summer press ON/OFF key to activate summer mode.

USER INSTRUCTIONS

In Standby Mode

Setting Day of Week

Press Mode Four times – Day of Week Flashes, Use UP/DOWN keys to set current Day Number 1 – 7 Press “Confirm” to store.

Setting Time

Press Mode Twice – Hours Flashes, Use UP/DOWN keys to set hours. Press mode again. Use UP/DOWN keys to set minutes. Press Confirm to store.

Turning OFF the built in Timer

Press and hold the TIME button, 3-time clocks will flash, Press confirm when clocks disappear from screen. Timer is now OFF

In Run Mode

Pressing “Time” will cycle between Manual ON/OFF and Timed.

Programmed times must be set using the Wi-Fi thermostat, see separate instructions supplied with the thermostat.

Fault Deletion Function

When a fault code shows on the display press the Confirm key to clear the fault.

Child Lock

Press “CONFIRM” for 5 Seconds, all keys are locked until “CONFIRM” is pressed again for 5 seconds

Frost Protection

In Standby the boiler will monitor the real time water temperature.

If the water temperature is < 5°C the boiler will run automatically until the water temperature has reached 15°C. The heating element will turn off, the pump will continue to run for 5 Minutes.

Cleaning Casings

Use hot soapy water applied with a damp cloth for the enamel, then dry with a soft dry cloth.

Simple Maintenance

Ensure that the natural ventilation around the boiler is not obstructed. If fitted in a compartment, ensure all ventilation grilles are clear.

The boiler has built in over temperature protection. If the water temperature exceeds 140°C the limit thermostat will activate, and the screen will be blank.

The thermostat will require re-setting by a qualified person.

FAULT FINDING

Information codes

Code	Protection Function	Description	
E2	Current leakage	Moisture on circuit board or the boiler has condensation internally	Qualified engineer to remove cover and dry/inspect circuit board
E3	Water temperature sensor	Sensor is short circuit or open circuit	Check sensor connection. Check sensor cable and replace if required
E5	DHW temperature sensor	Sensor is short circuit or open circuit	Check sensor connection. Check sensor cable and replace if required
E9	Antifreeze fault	Heating water temperature is too low	If the pipework is frozen the boiler will not be able to work.
EC	Display Disconnected with PCB	Display Disconnected with PCB	Check whether the cable between the display and the PCB is broken or whether the plug is loose.
F1	Dry Fire Protection	No water flow	Fill system and vent Press and hold TIME key for 6 seconds to re-set
F4	Low Water Pressure	System is low on water	Fill to correct pressure using filling loop
F6	No water Flow	Air in the system, no water or water pump not working, pump is blocked, water flow switch blocked, water flow switch is faulty	Vent system. Check system pressure. Check pump and flow switch for blockage/operation
	External earth leakage protector trip (RCD)	Display screen does NOT light up.	Check whether the leakage protector is damaged and replace it. Check whether the heater has leakage, Check whether there is leakage situation in the external input power wires
	Dry burning temperature controller trip	Display screen does NOT light up.	Check whether the temperature controller trips. If it trips, press the reset button. Check whether the waterway is blocked. Clean and unblock the pipeline. Check the flow of water pump.
	No heating	Equipment temperature does NOT rise.	Water temperature setting too low. 2. Return temperature setting too high. 3. Timing and opening 4. Indoor temperature control setting too low.
	No Hot Water (Combi Only)	Power Band working	Check High Limit Thermostat on DHW Heat Exchanger

INSTALLATION

INSTALLATION

Regulations

The Boiler must be installed in accordance with the following: -

BS EN 12828 – Heating systems in buildings: Design for water-based heating systems.

BS EN 12831 – Heating systems in buildings: Method for calculation of the design heat load.

BS EN 14336 – Heating systems in buildings: Installation and commissioning of water-based heating systems.

BS7671 – Requirements for electrical installations. IEE wiring Regulations. Seventeenth Edition.

BS EN 7593 – Code of practice for treatment of water in heating systems.

Health and Safety at Work Act

The installer should be aware of his responsibilities under the Act and provide where necessary, appropriate protection for persons carrying out the installation. In the interests of safety, a competent engineer should install the boiler and all wiring must be carried out in accordance with current IEE regulations.

IMPORTANT

ALL ELECTRICAL WORK MUST BE CARRIED OUT BY A QUALIFIED ELECTRICAL ENGINEER TO CURRENT IEE WIRING REGULATIONS.

UNPACKING THE BOILER

Carefully open the boiler carton, remove boiler and place in a safe place until required.

NOTE: ALWAYS STORE THE BOILER IN A DRY PLACE PRIOR TO FITTING.

SITING THE BOILER

IMPORTANT: NOT TO BE INSTALLED IN A SHOWER COMPARTMENT OR BATHROOM

Ensure adequate clearance is allowed for making water connections. Access is required to the front of the boiler for servicing. The boiler must also be fitted in a dry well-ventilated position, which is not subject to adverse temperature conditions. (See ventilation requirements).

Care should be taken when siting the appliance to make sure adequate access is available for future servicing of the appliance. Please note that the PCB and heat exchanger assembly may require removal during such times.

The front cover is held in position by four Phillips Head screws, two at the top and two at the bottom. Clearance at the top and bottom of the boiler should be adequate to allow access with a small Phillips screwdriver.

When removing the cover please unplug the cable between the display and main circuit board.

The boiler must be mounted on a suitable wall capable of bearing the weight of the boiler. Utilise all 6 fixing points on top and bottom fixing brackets.

INSTALLATION

Clearances

Please allow adequate clearance in front of the boiler for servicing and end user access.

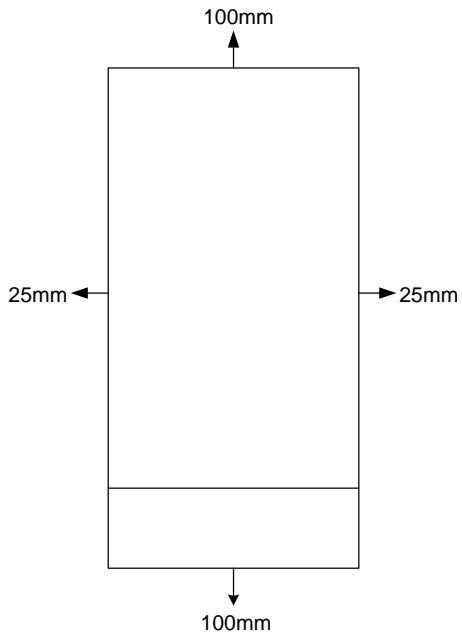

VENTILATION REQUIREMENTS

If the appliance is to be fitted in a confined space or compartment it is a requirement that adequate ventilation is provided to prevent the overheating of the boiler controls. Aeration of 110 cm^2 will be required To the compartment, in both high and low positions.

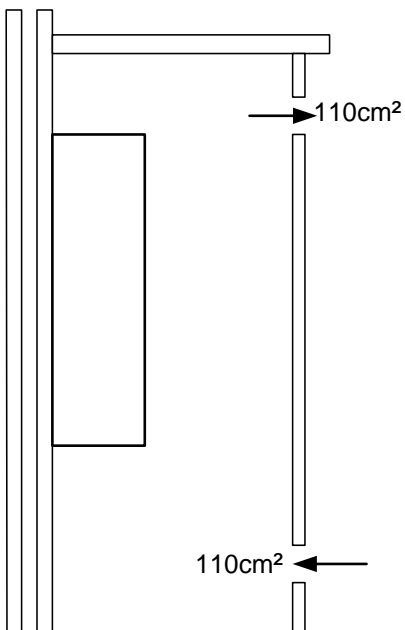

INSTALLATION

WATER SYSTEM

The installation must comply with the requirements of the following codes of practice.

BS EN 12828 – Heating systems in buildings: Design for water-based heating systems.

BS EN 12831 – Heating systems in buildings: Method for calculation of the design heat load.

BS EN 14336 – Heating systems in buildings: Installation and commissioning of water-based heating systems.

BS EN 7593 – Code of practice for treatment of water in heating systems.

Isolation valves must be fitted. These should be of a full-bore type.

The water system must be thoroughly flushed out before adding inhibitor to BS 7593: 1992 treatment of water in central heating boiler.

Fill the system. Vent all air from system. Vent Pump. Clear any air locks and examine the system for water leaks.

IMPORTANT: ENSURE ALL SERVICE VALVES ARE IN AN OPEN POSITION.

IMPORTANT: THIS BOILER IS TO BE FITTED ON FULLY PUMPED SYSTEMS ONLY.

IMPORTANT: COMBINATION BOILER ONLY – ALL DOMESTIC HOT WATER OUTLETS SHOULD BE RESTRICTED TO 5L/M

SEALED WATER SYSTEM REQUIREMENTS

The installation must comply with the appropriate requirements of the current issue of BS4814, BS5449, BS6798 and BS7074 Part 1 and 2.

Safety Valve

A 3-bar safety valve is fitted within the unit. The drain must be routed to the outside of the building. The drain must not discharge above an entrance or a window or any public access area, be clear of any electrical fittings and positioned so that any discharge can be seen.

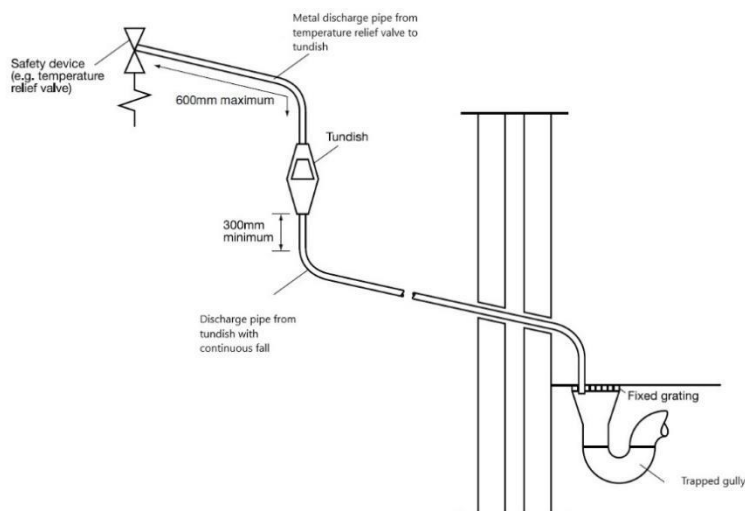

INSTALLATION

Expansion Vessel Capacity

Note the internal 5 litre expansion vessel might not accommodate the entire system volume.

A second diaphragm type expansion vessel, conforming to the current issue of BS4814 might be required. The expansion vessel must be connected to the systems at a point close to the inlet side of the circulating pump. The expansion vessel volume depends on the total water system volume and the initial system design pressure. For any system an accurate calculation of vessel size is given in the current issue of BS5449 and BS7074 Part 1.

The water content of the boiler is given in the technical specification. Note a higher initial design pressure requires a larger volume expansion vessel.

The charge pressure must not be less than the static head of the system, which is the highest point of the system above the expansion vessel.

NOTE: Failure to ensure the correct vessel size could result in premature failure of the expansion vessel which in turn may adversely affect other components in the system i.e., circulating pump and diverter valve.

Capacity of Expansion Vessel

Where design information is not complete the following chart can be used for selecting the size of the vessel, it should be noted that the size given in the table take account of fault conditions.

Safety valve setting (bar gauge)	3 Bar		
Vessel charge and initial system pressure (bar gauge)	0.5	1.0	1.5
Total water content of system (litre)	Vessel volume (litre)		
25	2.3	3.3	5.9
50	4.7	6.7	11.8
75	7.0	10.0	17.7
100	9.4	13.4	23.7
125	11.7	16.7	29.6
150	14.1	20.1	35.5
175	16.4	23.4	41.4
200	18.8	26.8	47.4

System Temperature

The normal running temperature of the heating system is 75°C, if a fault was to occur then the safety device would allow the system temperature to rise to 100°C. It is recommended that this figure be used in the calculations of vessel size.

Pressure Gauge

A 0 to 4 bar pressure gauge is fitted within the unit.

Drain Tapping

A drain tapping must be provided at the lowest point of the system, which will allow the entire system to be drained.

INSTALLATION

System Makeup

Provision can be made by pre-pressurisation of the system via a temporary hose connection and through a double check valve (non-return) and stop valve.

There must be no permanent connection to the mains water valve supply even through a non-return valve.

Maximum Cold Water inlet pressure not to exceed 6 bar (Combi Only)

Inhibitor

If using an existing system take care to drain down the entire system including the radiators, then thoroughly clean out before fitting the boiler. Attention is drawn to the current issue of BS5449 and BS7593 on the use of inhibitors in central heating systems.

Magnetic Boiler Filter

To be fitted in the return pipe work close to the boiler.

Scale Inhibitor

The Aztec Mini Combination boiler **MUST** be fitted with an inline scale inhibitor (not supplied) on the cold feed inlet pipe.

Failure to do so will invalidate the warranty.

Pump Setting

To avoid any primary water flow problems, it is important to commission the pump to the correct setting to suit the system.

Please see page 18 for pump setting details.

Water Connections

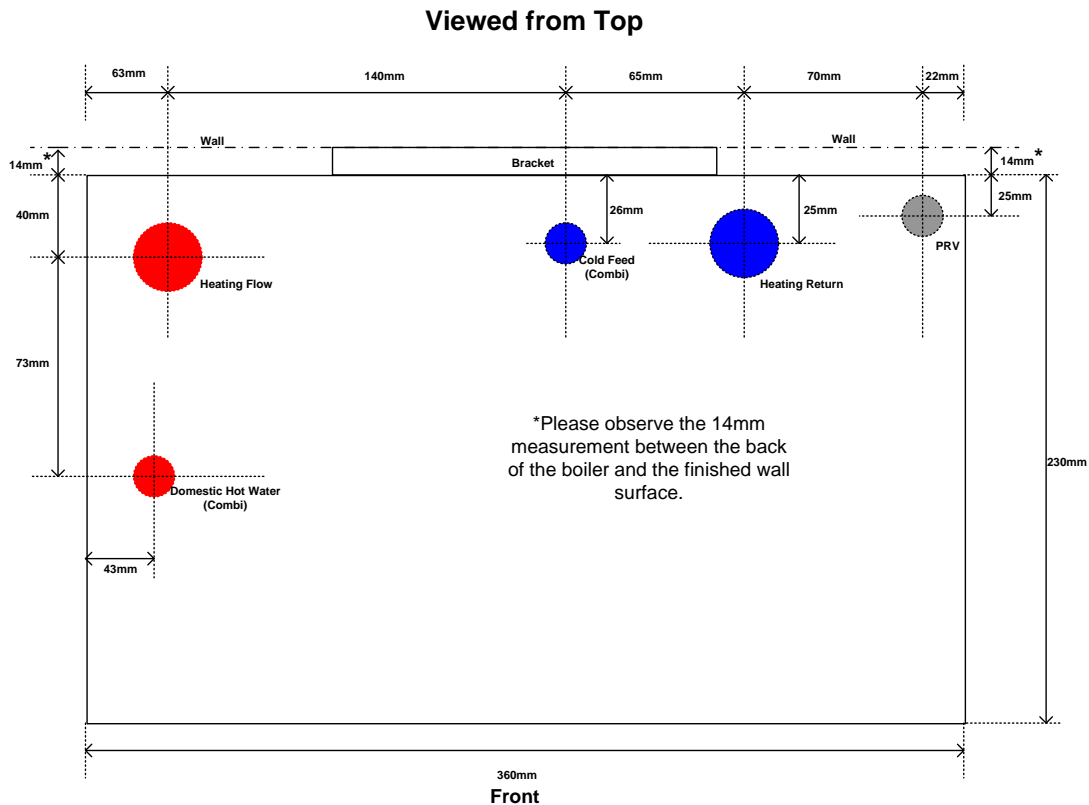

INSTALLATION

Pipe Work Layout

Combi

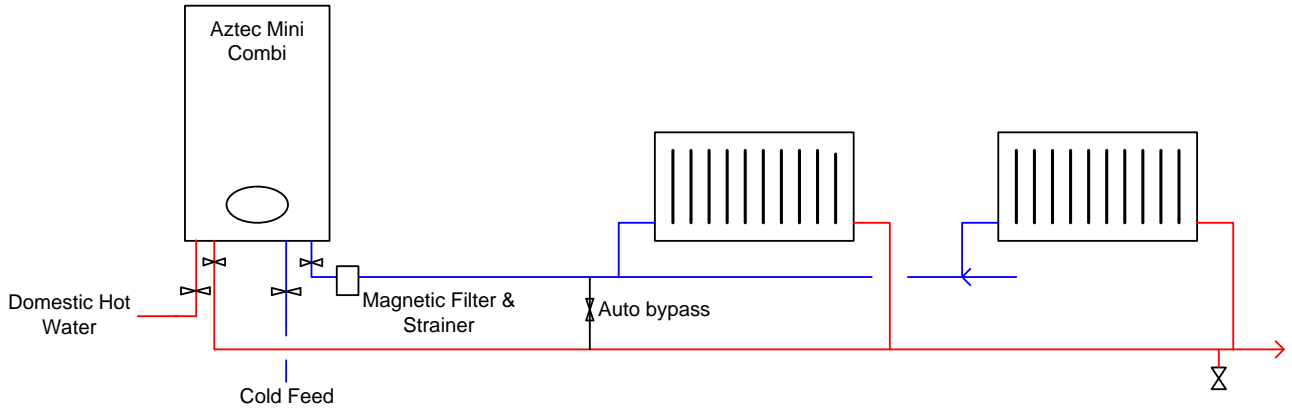

System – Heat Only – Sealed System

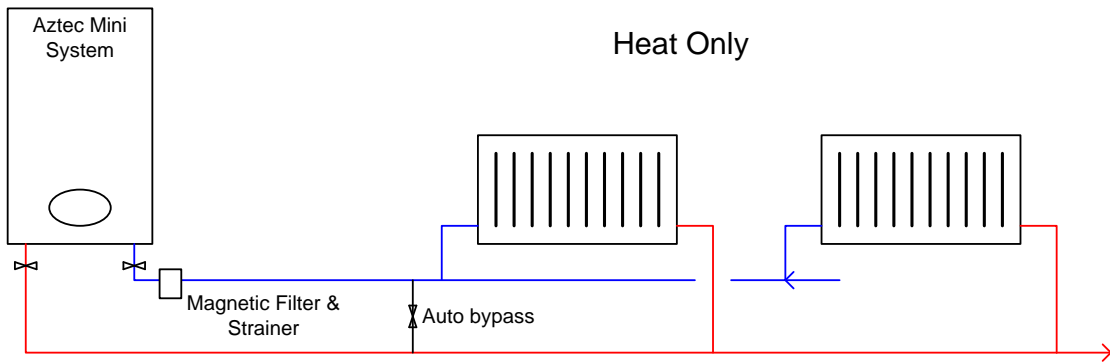

INSTALLATION

WIRING INSTRUCTIONS

All electrical work must be carried out in accordance with current IEE wiring regulations.

Before commencing installation check power supply to property to ensure that there is enough current and voltage available for size of boiler fitted. Consider requirements of other electrical appliances, the boiler must be connected to the mains supply by means of a double pole linked switch with 3mm contact gap in both poles.

IMPORTANT:

After completing electrical installation work preliminary safety checks should be carried out as described in BS 7671:2001

NOTE: RCD unit can be used as the isolating switch if mounted close enough to the boiler.

Miniature circuit breakers MCB's **MUST** be fitted between RCD unit and boiler and RCD and any external controls. Refer to technical specification. For MCB ratings refer to wiring diagram.

It is important the correct size MCB is used in the supply from the RCD to the boiler.

ELECTRICAL CONNECTIONS

WARNING: THIS APPLIANCE MUST BE EARTHED.

The mains connection block is located inside the boiler on a bracket at the top right-hand side of the boiler which can be directly wired to the boiler supply MCB. Use the correctly rated cable.

IMPORTANT: CORRECT POLARITY MUST BE OBSERVED WHEN BRINGING THE MAINS SUPPLY INTO THE BOILER.

External Controls

Control wiring is volt free, do not apply 230v This will invalidate the warranty.

Using the two-core black switch cable under the boiler any twin channel programmer capable of volt free switching can be used on the Aztec Mini System boiler. When using the "S-Plan" system the micro switches in the 2 zone valves must be supplied from the two-core black switch cable.

Low Voltage System Boiler/nest/S-Plan

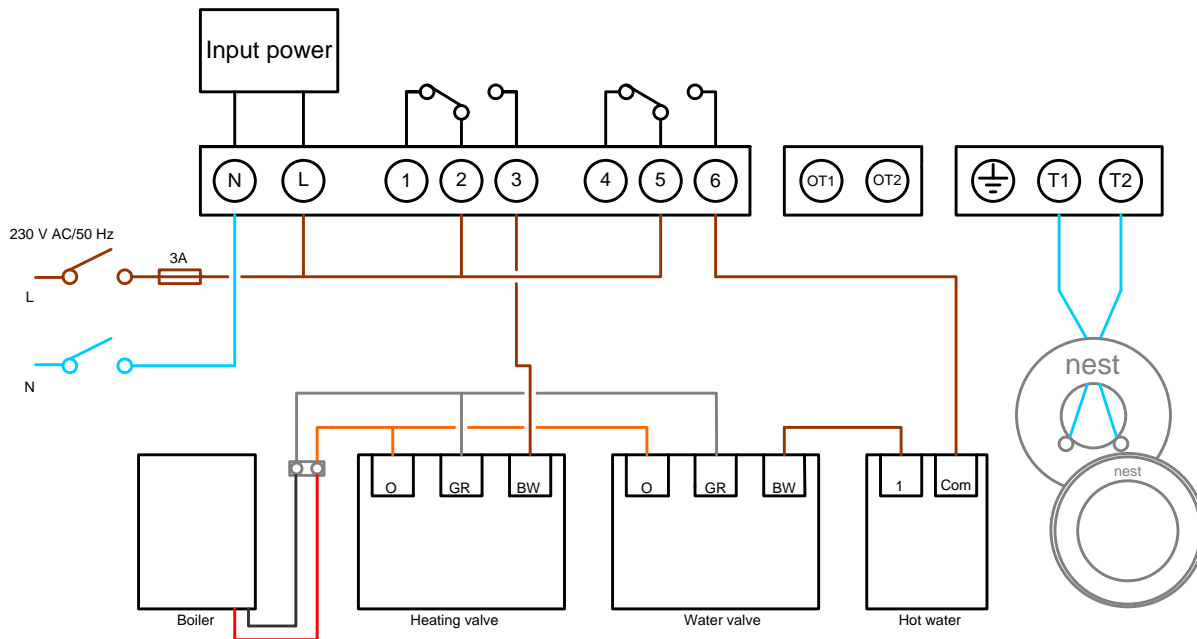

Combination Boiler Only THP1002 Series Wi-Fi Thermostat

The combination boiler is supplied with a Wi-Fi wall mounted thermostat which allows the end user to control the heating from a smart phone or tablet.

If using the Mini system boiler for heat only the THP1002 can be used, please contact Trianco for details.

The thermostat requires a 230V supply and communicates with the boiler via a twin core cable.

Connect between terminals 1 & 2 and the twin core cable inside the boiler using the connections provided.

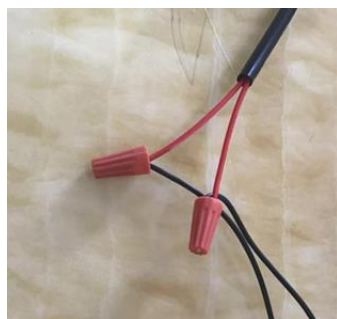
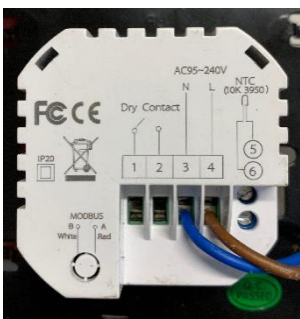

For further information on installing and using the thermostat please refer to the installation manual supplied.

Pump setup and display

Settings and display panels

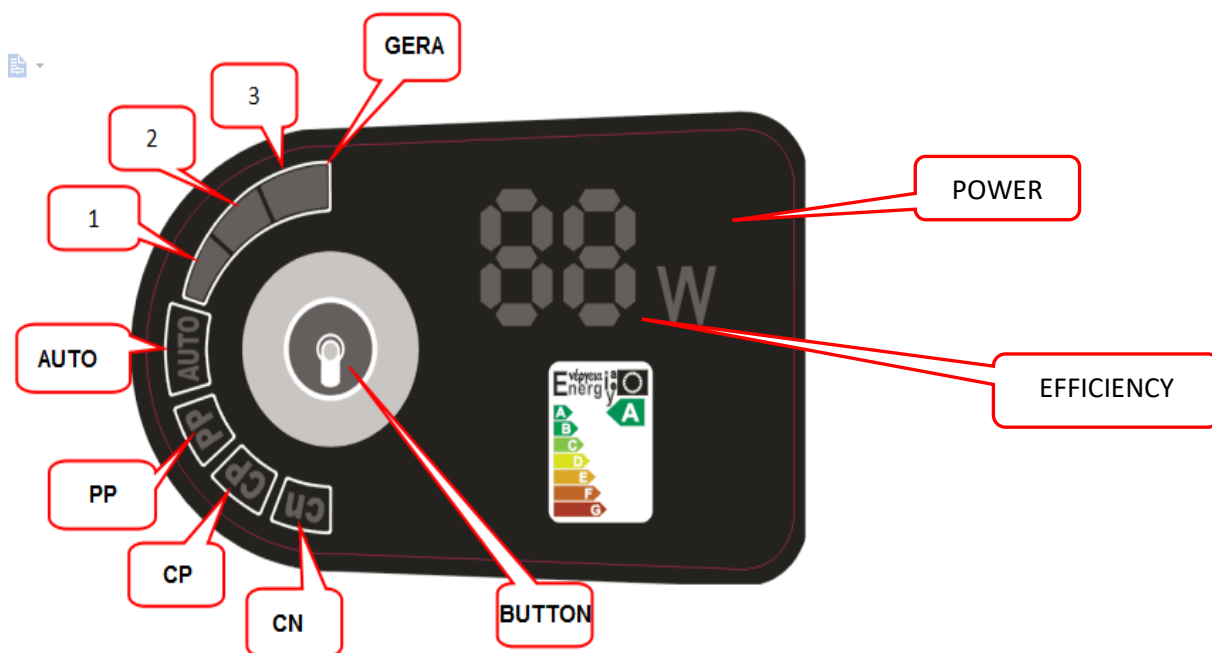

Function mode

- 1) Constant speed mode, with a total of 3 levels, respectively represented by + and ;
- 2) Proportional mode, there are 3 levels, respectively represented by + and ;
- 3) Constant pressure mode, with a total of 3 levels, respectively represented by + and ;
- 4) Adaptive mode :

The mode switch.

After energizing, tap the button on the panel to switch different working modes, in order:

- CN I , indicator light + → CN II , indicator light + → CN III , indicator light + → PP I , indicator light + → PP II , indicator light + → PP III , indicator light + → CN III , indicator light + → CP I , indicator light + → CP II , indicator light + → CP III ,
- Indicator light + → Adaptive mode

This product has the function of power failure memory. When the function is selected or the power is suddenly cut off during operation, the operation state will remain selected or before power failure after the call is restarted.

Normal display and operation

After power supply, all LED flashes for 5 seconds. After 5 seconds, the current power value (W) will be displayed by default. Function and gear position change successively after each press: The Cn III - CP I - CP II - CP III - PP I - PP II - PP III - AUTO - Cn I - Cn II - Cn III...And so on, The factory default Cn III products. When there is no operation within 5 seconds, the current gear and power value (W) will be displayed after 5 seconds. Press the button for 2 seconds to display the current pump speed (mechanical frequency).

Fault display

When there is a failure of the pump, the seven sections of digital display will flash, showing the current fault code, the fault code definition is as follows:

Fault code	Code definition	Fault code	Code definition	Fault code	Code definition
E0	IPM module failure	P0	U phase Current overload	P4	Motor Out of step
E2	Drive anomalies	P1	V phase Current overload	P5	The current offset
E3	The reserved	P2	W phase Current overload	P6	Lack of phase protection
E4	Voltage protection	P3	Motor stall		

Adaptive mode (AUTO)

AUTO adaptive function is suitable for most applications, especially for floor heating system and double pipe heating system. AUTO adaptive function is different from other functions in that it has the ability of self-learning and can adjust the performance of the water pump by adaptive movement within a range. Its regulating effect cannot be optimized over time, but gradually reaches the best setting. When the power supply is disconnected, the pump will store the AUTO parameters in the internal storage. When the power supply is restored, the performance parameters will be automatically restored.

TECHNICAL DETAILS

Combination Boiler

TECHNICAL DETAILS	UNIT	8kW	10kW	12kW
Electrical Input	kW* ¹	12	12	12
Supply Current	Amp	51	51	51
RCD Rating	Amp	63	63	63
Minimum Cable Size	mm	10	10	10
D.H.W @45°C	Ltr/min* ²	5	5	5
Weight	Kg	23		
Water Content	litres	0.8		
Width	mm	360		
Depth	mm	240		
Height	mm	580		
Mains Supply	230V 50Hz			
Max Operating Pressure	300 kPa / 3 bar			
Test Pressure	600 kPa / 6 bar			
Minimum Flow Rate	8 l/min			
Boiler Flow Temperature	Adjustable between 30°C and 85°C			
Limit Thermostats	Factory set at 140°C			
CH Flow & Return	¾ BSP Male			
DHW Inlet & Flow	½ BSP Male			
Maximum Flow Temp CH	85°C			
Pressure Gauge	0 – 4 bar			
Pressure Relief Valve	3 bar			
Pump	BGE15-10A			
Expansion Vessel	5Ltr charge 1.5 bar			
Available System Head	3m			
Maximum Cold Water inlet Pressure	6 bar			
Casing Finish	Stove enamelled white			

*¹ Electrical input for domestic hot water on all combination boilers equals 12kW.

*² With flow restrictors fitted to all domestic hot water outlets to offer 35°C temperature rise.

TECHNICAL DETAILS

System Boiler

TECHNICAL DETAILS	UNIT	8kW	12kW	14kW
Electrical Input	kW	8	12	14
Supply Current	Amp	35	51	61
RCD Rating	Amp	40	63	80
Minimum Cable Size	mm	6	10	16
Weight	Kg	23		
Water Content	litres	0.8		
Width	mm	360		
Depth	mm	240		
Height	mm	580		
Mains Supply	230V 50Hz			
Max Operating Pressure	300 kPa / 3 bar			
Test Pressure	600 kPa / 6 bar			
Minimum Flow Rate	8 l/min			
Boiler Flow Temperature	Adjustable between 30°C and 85°C			
Limit Thermostats	Factory set at 140°C			
CH Flow & Return	¾ BSP Male			
Maximum Flow Temp CH	85°C			
Pressure Gauge	0 – 4 bar			
Pressure Relief Valve	3 bar			
Pump	25/60			
Expansion Vessel	5Ltr charge 1.5 bar			
Available System Head	3m			
Casing Finish	Stove enamelled white			

BOILER SPARES

ITEM	DESCRIPTION	QTY	8Kw Combi	10Kw Combi	12Kw Combi	8Kw System	12kW System	14kW System
1	Outer Cover - 1	1	225001	225001	225001	225001	225001	225001
2	PCB	1	225002	225002	225002	225002	225002	
3	Heat Exchanger	1	225003	225003	225003	225003	225003	
4	Heating Flow Connection	1	225004	225004	225004	225004	225004	225004
5	DHW Heat Exchanger	1	225005	225005	225005	NA	NA	NA
6	DHW Limit Thermostat	1	225006	225006	225006	NA	NA	NA
7	Pressure Switch	1	225007	225007	225007	225007	225007	225007
8	Pressure Gauge	1	225008	225008	225008	225008	225008	225008
9	Safety Valve	1	225009	225009	225009	225009	225009	225009
10	Expansion Board	2	225010	225010	225010	NA	NA	NA
10	Expansion Board	1	NA	NA	NA	225011	225011	225011
11	Display	1	225012	225012	225012	225012	225012	225012
12	Display Cover	1	225013	225013	225013	225013	225013	225013
13	Pump	1	225014	225014	225014	225014	225014	225014
14	Heating Flow Sensor	1	225015	225015	225015	225015	225015	225015
15	DHW Flow Sensor	1	225016	225016	225016	NA	NA	NA
16	Cable Gland	1	225017	225017	225017	225017	225017	225017
17	Cable Gland	1	225018	225018	225018	225018	225018	225018
18	Boiler Casing	1	225019	225019	225019	225019	225019	225019
19	Cable Clamp	1	225020	225020	225020	225020	225020	225020
20	Heating Limit Thermostat	1	225021	225021	225021	225021	225021	225021
21	5L Expansion Vessel	1	225022	225022	225022	225022	225022	225022
22	Control Box Cover	1	225023	225023	225023	225023	225023	225023
23	DHW Pipe	1	225024	225024	225024	NA	NA	NA
24	Cold Water Inlet Pipe	1	225025	225025	225025	NA	NA	NA
25	Heating Flow	1	225026	225026	225026	225026	225026	225026
26	Heating Return	1	225027	225027	225027	225027	225027	225027
27	Expansion Vessel Connection	1	225028	225028	225028	225028	225028	225028
28	Pressure Relief Pipe	1	225029	225029	225029	225029	225029	225029
29	Brass valve set	1	225030	225030	225030	225030	225030	225030

BOILER SPARES

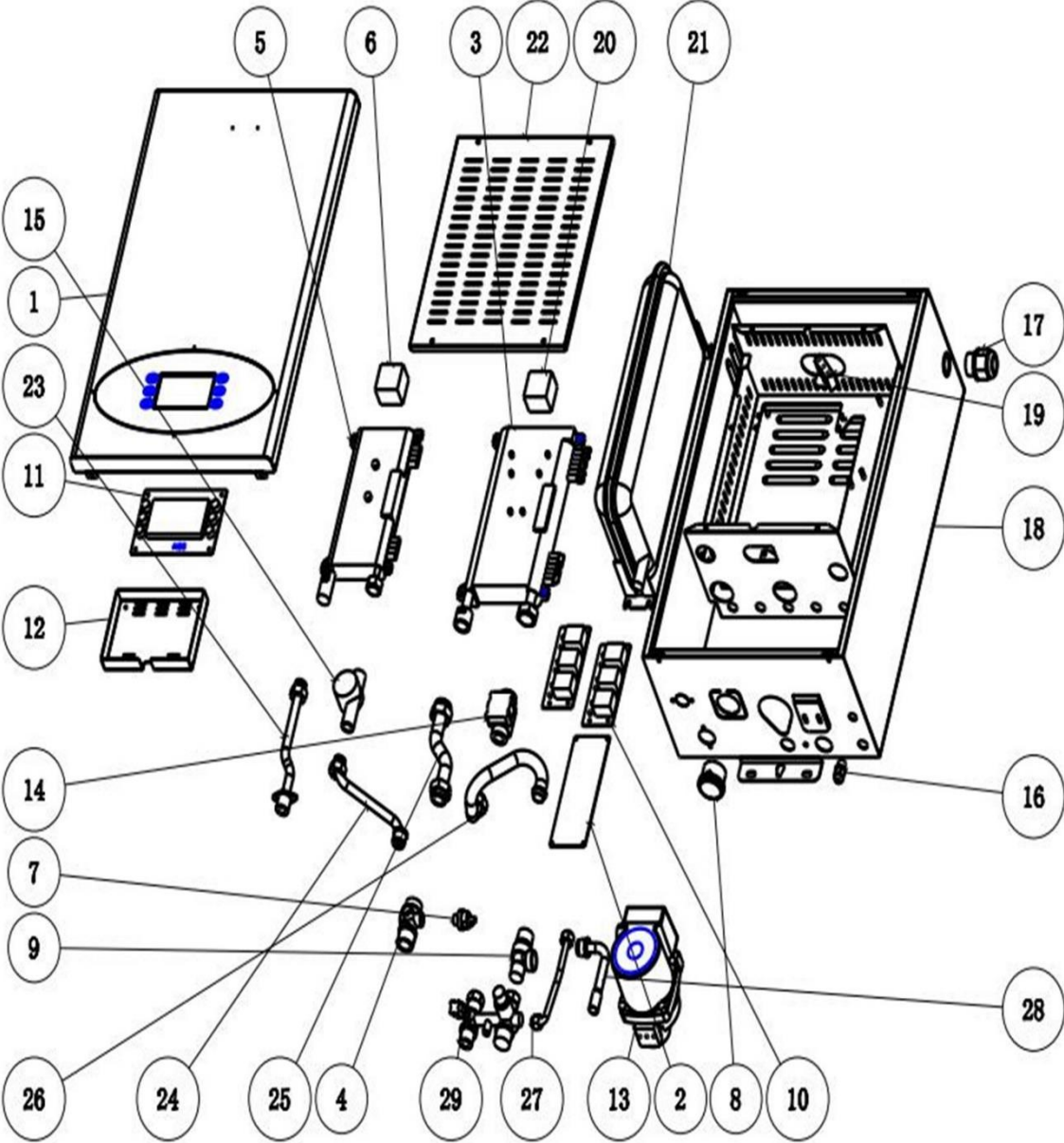

Aztec Commissioning Report

Installation Details	
Name:	
Address:	_____

Tel:	_____
Mobile No:	_____
Email:	_____

Commissioning Engineer Details	
Name:	
Address:	_____

Tel:	_____
Mobile No:	_____
Email:	_____

Commission Details

Date of Completion: _____ Date of Commission: _____

Serial Number: _____

RCD - Existing/New: _____ Size: _____

Supply Cable - Existing/New: _____ Diameter (mm): _____

Isolation valves fitted to all boiler outlets Y/N _____

Magnetic Filter Fitted to Heating circuit Y/N _____

Combination Boiler

Incoming Cold-Water Pressure _____ Bar

In-line scale inhibitor fitted _____

By signing you agree that you have installed the boiler in accordance with these instructions and that the boiler is working as intended.

Plumber Signed: _____ Date: _____

Electrician Signed: _____ Date: _____

Customer Acceptance

I confirm that I have received training and instruction on how to operate and maintain this appliance.

I understand the warranty on this product, and I have been provided with a User Manual and Operating Instructions.

Customer Signature: _____ Date: _____



TRIANCO

TR ENGINEERING LTD
5 Wortley Road
Rotherham
S61 1LZ

Tel: (0114) 2572300

Fax: (0114) 2571419

www.trianco.co.uk

© TR Engineering Limited

Copyright in this brochure and the drawings and illustrations contained in it is vested in TR Engineering Limited and neither the brochure nor any part thereof may be reproduced without prior written consent.

TR Engineering Limited's policy is one of continuous research and development. This may necessitate alterations to this specification

Nov 2021