



TRIANCO

BRINGING HEAT TO LIFE

**Air Source Heat Pump
S700, S1200
Installation and Service Manual**

TABLE OF CONTENTS

Introduction.....	3
General information	3
Cycle diagram	4
Safety precautions.....	5
Warning	5
Caution	6
Operating the unit.....	7
Features and function.....	7
User interface	7
Buttons.....	8
Controller operations.....	8/9
Parameter checking and adjustment.....	10
Unit status query table	10
Parameter list.....	10
Error code table	11
Wiring diagram	12
Installation of the unit.....	13
Installation guidelines	13
Precautions for selecting the location	13
Selecting a location in cold climates	13
Installation space	14
Mounting the unit	14
Water pipe work	15
Checking the water circuit	15
Connecting the water circuit	15
Charging water	16
Piping insulation	16
Field wiring	16/17
Pre-operation Checks	17
Checks before initial start-up	17
Maintenance.....	17
Installation plan for complete system.....	18
Trouble shooting.....	19
General guidelines	19
Error codes and troubleshooting	20/21
After Sales service.....	22
Technical specification.....	23
Heating Performance.....	23

INTRODUCTION

This manual includes the necessary information about the unit. Please read this manual carefully before you install, operate, and maintain the unit.

By Fitting this Activair Air source Heat Pump, you agree:

- **The unit has been received in good condition.**
- **You have carried out a heat loss calculation and are sure that this heat pump is suitable.**
- **You have carried out a load and voltage test to determine the correct size of breaker to be used.**
- **You meet the requirements of the appropriate Building Regulations**

HEALTH AND SAFETY

INFORMATION FOR THE USER, INSTALLER AND SERVICE ENGINEER

Under the Consumer Protection Act 1987 and the Health and Safety at Work Act 1974, it is a requirement to provide information on substances hazardous to health (COSHH Regulations 1998).

TR Engineering takes every reasonable care to ensure that its products are designed and constructed to meet these safety requirements when the products are professionally installed and used. To fulfil the requirements, products are comprehensively tested and examined before despatch.

When working on the appliance, it is the responsibility of the user or engineer to ensure that personal protective clothing or equipment appropriate to parts that could be considered hazardous or harmful is worn.

This appliance may contain some of the items below:

Glass rope, mineral wool, insulation pads, ceramic fibre, and glass insulation.

When handling, avoid inhalation and contact with eyes. These may be harmful and cause irritation to the skin, eyes, nose, or throat. Use disposable gloves, face masks and eye protection.

After handling, wash hands and other exposed areas. When disposing of materials, limit dust and the risk of inhalation by using water spray. Ensure materials are securely wrapped.

Seek urgent medical attention if inhaled or ingested. Exposure to eyes and skin should be followed by immediate cleansing of the affected areas and medical attention if necessary.

Glues, Sealants and Paints

The glues, sealants and paints used present no known hazards when the appliance is used in the manner for which it is intended.

TEST SPECIFICATION

EN 14825:2018

EN 14511 – 4:2018 Clause 4

Cycle diagram

The whole cycle diagram is shown below.

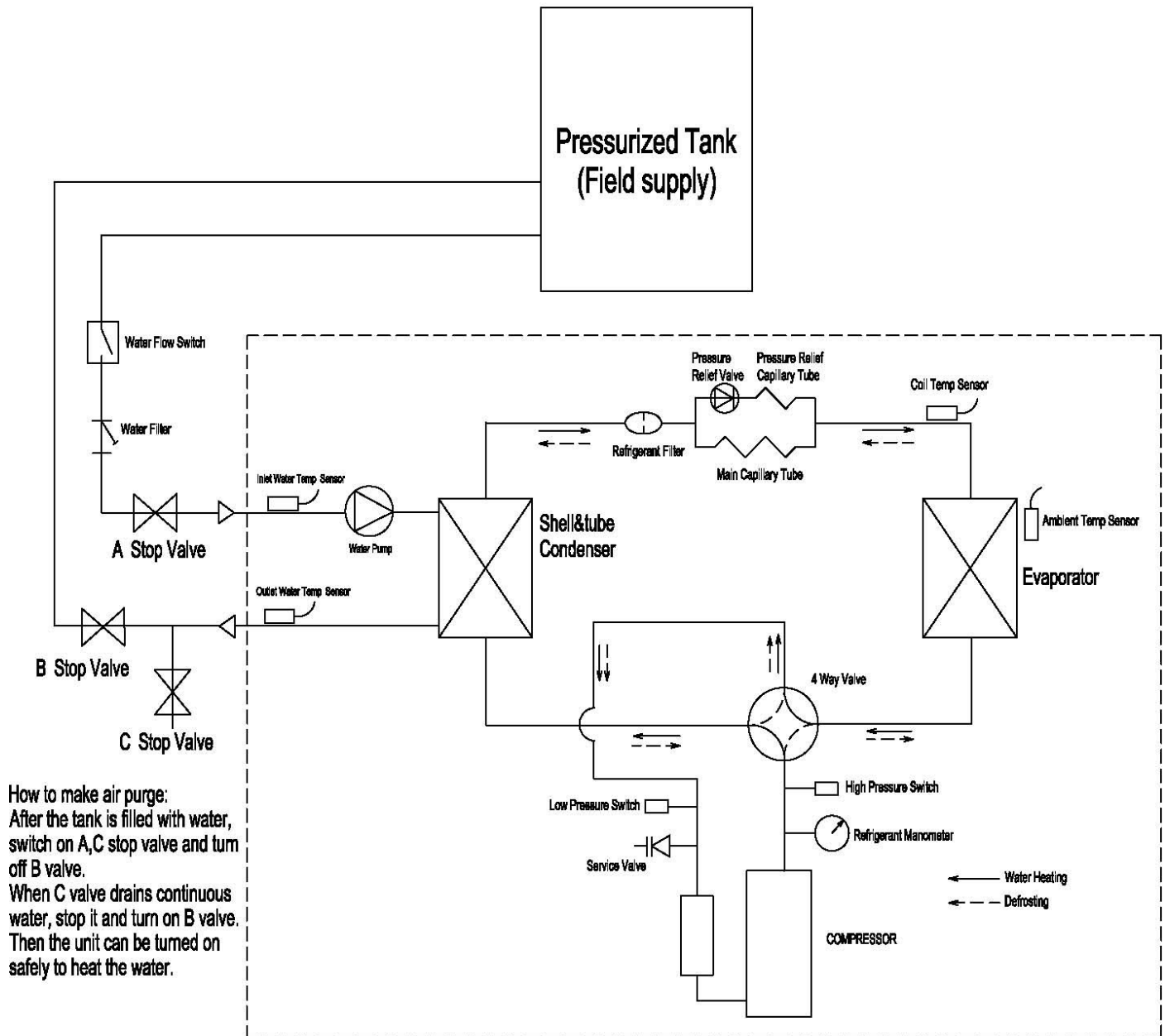

Heat Pump Unit

SAFETY PRECAUTIONS

To prevent injury to the user, other people, or property damage, the following instructions must be followed. Incorrect operation due to ignoring of instructions may cause harm or damage.

Install the unit only when it complies with local regulations, by-laws, and standards. Check the main voltage and frequency. This unit is only suitable for earthed sockets.

The following safety precautions should always be considered:

- Be sure to read the following WARNING before installing the unit.
- Be sure to observe the cautions specified here as they include important items related to safety.
- After reading these instructions, be sure to keep it together with the manual in a handy place for future reference.

WARNING

Only to be installed by a professional person.

Incorrect installation could cause injury due to fire, electric shock, the unit falling or leakage of water. Consult the dealer from whom you purchased the unit or a specialized installer.

Install the unit securely in a place.

When insufficiently installed, the unit could fall causing injury. When installing the unit in a small room, please take measures (like sufficient ventilation) to prevent the asphyxia caused by the leakage of refrigerant.

Use the specified electrical wires and attach the wires firmly to the terminal board (connection in such a way that the stress of the wires is not applied to the sections).

Incorrect connection and fixing could cause a fire.

Be sure to use the provided or specified parts for the installation work.

The use of defective parts could cause an injury due to fire, electric shocks, the unit falling etc.

Perform the installation securely and please refer to the installation instructions.

Incorrect installation could cause an injury due to fire, electric shocks, the unit falling, leakage of water etc.

Perform electrical work according to the installation manual and be sure to use a dedicated section.

If the capacity of the power circuit is insufficient or there is an incomplete electrical circuit, it could result in a fire or an electric shock.

The unit must always have an earthed connection.

If the power supply is not earthed, you may not connect the unit.

Never use an extension cable to connect the unit to the electric power supply.

If there is no suitable, earthed wall socket available, have one installed by a recognized electrician.

Do not move/repair the unit yourself.

Improper movement or repair on the unit could lead to water leakage, electrical shock, injury, or fire. Have any repairs and/or maintenance only carried out by a recognized service engineer.

Do not plug or unplug the power supply during operation

There is a risk of fire or an electric shock

Do not touch/operate the unit with wet hands

There is a risk of fire or an electric shock

Do not place a heater or other appliances near the power cable

There is a risk of fire or an electric shock

Be cautious that water could not be poured into the product directly, do not allow water to run into electric parts

There is a risk of fire or an electric shock

If the supply cord is damaged, it must be replaced by the manufacturer or its service agent or a similarly qualified person to avoid a hazard.

This appliance has not been designed for use by persons (including children) with reduced physical, sensorial, or mental faculties or by persons without any experience or knowledge of heating systems, unless they act under the safety and supervision of a responsible person or have received prior training concerning the use of the appliance.

Children should be supervised to ensure that they do not play with the appliance

 IF THE PRODUCT IS NOT TO BE USED FOR AN EXTENDED PERIOD OF TIME, WE STRONGLY RECOMMEND NOT TO SWITCH 'OFF' THE POWER SUPPLY OF THE UNIT.

 IF THE POWER IS NOT SUPPLIED, THE ANTI-FREEZE FUNCTION WILL NOT BE PERFORMED.

 **CAUTION**

Do not install the unit in a place where there is a chance of flammable gas leaks.

If there is a gas leak and gas accumulates in the area surrounding the unit, it could cause an explosion.

Perform the drainage/piping work according to the installation instruction.

If there is a defect in the drainage/piping work, water could leak from the unit and household goods could get wet and be damaged.

Do not clean the unit when the power is 'on.'

Always shut 'off' the power when cleaning or servicing the unit. If not, it could cause an injury due to the high-speed running fan or an electrical shock.

Do not continue to run the unit when there is a suspected fault.

The power supply needs to be shut 'off' to stop the unit; otherwise, this may cause an electrical shock or fire.

Be cautious when unpacking and installing the product.

Sharp edges could cause injury. Especially watch the edges and the fins on the heat exchanger of the product.

Always check for gas (refrigerant) leakage after installation or repair of product.

Low refrigerant levels may cause failure of the product.

Keep level even when installing the product.

This is to avoid vibration or water leakage.

Do not place hands or fingers or others into the fan, or evaporator.

The ventilator runs at high speed, this could cause significant injury.

OPERATING THE UNIT

Operating the unit comes down to operating the digital controller.

- ⚠ NEVER LET THE DIGITAL CONTROLLER GET WET. THIS MAY CAUSE AN ELECTRIC SHOCK OR FIRE.
- ⚠ NEVER PRESS THE BUTTONS OF THE DIGITAL CONTROLLER WITH A HARD, POINTED OBJECT. THIS MAY DAMAGE THE DIGITAL CONTROLLER.
- ⚠ NEVER INSPECT OR SERVICE THE DIGITAL CONTROLLER YOURSELF, ASK A QUALIFIED SERVICE PERSON TO DO THIS.

Features and functions

Basic controller functions

The basic controller functions are:





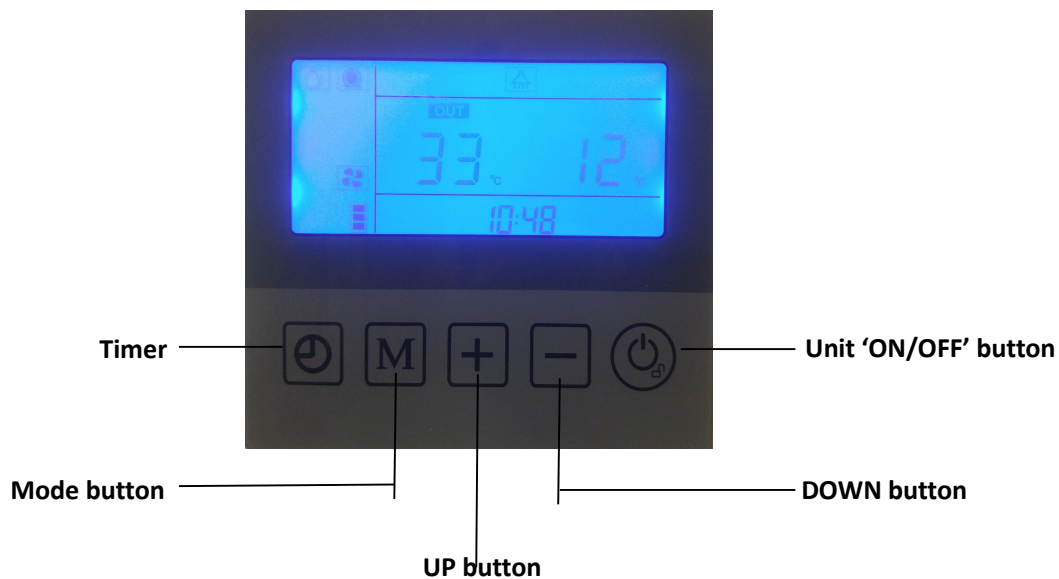



- Turning the heat pump 'ON'/'OFF'.
- 24 hours real time clock.
- Timer 'ON' and timer 'OFF'.
- Parameter adjustment

User interface



















Buttons













-  Unit ON/OFF button
 - ✧ Under unit unlock status, press this button for 1 second to switch unit ON/OFF.
 - ✧ Under other setting status, press this button to return to main interface.
 - ✧ Under locked screen status, press this button for 5 seconds to unlock screen.

-  Mode button
 - ✧ Under main interface, press this button to check unit status
-  and  adjust button
 - ✧ Turn pages up and down to check, modify parameters.
 - ✧ Combining with  to query and change parameters.
 - ✧ Under unit ON status, press  and  to set temperature in current mode.
-  Timer button
 - ✧ Press this button for 10 seconds to set clock.
 - ✧ Press this button to enter Timer ON/OFF setting mode, combining with  and  buttons to set 2 groups of Timer ON/OFF.

Controller operations

- **Parameter query and settings**
 - ✧ User parameter query and settings (available when unit ON or OFF).
 - ✧ On main interface screen, press  for 3 seconds to enter user parameter query interface, press  and  buttons to check each parameter.
 - ✧ On user parameter query interface, press  to enter parameter setting interface, press  and  buttons to modify parameter value, press  again to go back to parameter query status.
 - ✧ Under user parameter query or setting interface, if buttons are not pressed within 30 seconds, user parameter query or setting interface will automatically exit and return to main operation interface.  can be pressed to go back to main operation interface.
- **Clock settings**
 - ✧ Under main operation interface screen, press  for 5 seconds to enter clock setting interface.
 - ✧ On clock setting interface screen, press  on time, the “hour” digit is flashing, then press  and  buttons to modify value for “hour.”
 - ✧ After setting “hour” digit, press  again, the “minute” digit is flashing, then press  and  buttons to modify value for “minute.”
 - ✧ After setting “minute” digit, press  again to confirm clock settings and go back to main operation interface.
 - ✧ Under clock setting interface, if buttons are not pressed within 30 seconds, display will automatically confirm current clock settings and go back to main operation interface.
 - ✧ Under clock setting interface, press  to confirm clock settings and go back to main operation interface.

● Timer settings

- ◇ On main operation interface screen, press  to enter Timer setting interface.
- ◇ Then press  and  to set Timers, there are 4 groups of Timers.
- ◇ When Time 1 is flashing, press  to enter Timer 1 ON “hour” digit setting which will flash, then press  and  buttons to set value for “hour” digit.
- ◇ After setting Timer 1 ON “hour” digit, press  again to enter into Timer 1 ON “minute” digit which will flash, then press  and  buttons to set value for Time 1 ON “minute” digit.
- ◇ After setting Timer 1 ON “minute” digit, press  again to enter into Timer 1 OFF “hour” digit, The setting way is same as above.
- ◇ When finish setting Timer OFF time, press  again to confirm current Timer settings, and enter Timer 2 ON/OFF settings, the operation is same as Timer 1 settings, then back to main operation interface.
- ◇ On Timer setting interface screen, press  for 5 seconds to cancel current Timer ON/OFF settings.
- ◇ On Timer setting interface screen, if there is no press on any button for continuous 30 seconds, system will automatically confirm current Timer settings and return to main operation interface (Timer memory is available if power off.).
- ◇ On Timer setting interface screen, press  to confirm current Timer settings and back to main operation interface.
- ◇ Settings way for other groups of Timers is same as Timer 1.
- ◇ Timer 1,2 are for unit ON/OFF, Timer 3 is for return water, Timer 4 is for water refilling.



● Lock and unlock buttons

- ◇ Under locked button status, press  for 3 seconds, after a buzzer, button will be unlocked.
- ◇ Automatically lock buttons if there is no press on any button within 60 seconds.



● Cooling mode

- ◇ Press  for 5 seconds, can switch different modes: cooling, heating/hot water.

● Forced defrosting

- ◇ Under unit ON status, press  for 3 seconds to enter forced defrosting.
- ◇ Press  for longer time till unit turns off, 3 minutes later the forced defrosting will exit. Or if defrosting time reaches Parameter “H5”, the forced defrosting will exit as well.

● Remove error history record

- ◇ On error history query interface screen, press  and  for 5 seconds to remove error history records.

● Reset

- ◇ Under unit OFF status, press  and  for 5 seconds, parameters will resume initial factory default value.

PARAMETER CHECKING AND ADJUSTMENT

Unit status query table

Code	Parameter Name
A1	Coil temperature
A2	Return gas temperature
A3	Exhaust gas temperature
A4	Ambient temperature
A5	Outlet water temperature
A6	Return water temperature
A7	Reserved
A8	Compressor current
A9	Opening of the EEV
A10	Reserved
E1~E6	Error code display

Parameter list

Some parameters can be checked and adjusted by the controller. Below is the parameter list.

User parameters (can be adjusted by users.)

Code	Parameter Name	Range	Default
L2	Outlet water temperature variation for compressor start	3°C~18°C	5°C
L3	Outlet water temperature set when heating	32°C~40°C Parameter F1	40°C
L4	Outlet water temperature set when cooling	8-32°C	12°C
L5	Ambient temperature for electric heater start	0°C~35°C	5°C
L6	Return water temperature	30°C~40°C	40°C
L7	Allowable water-refill temperature	20°C~40°C	20°C
L8	Compressor current	0~40A	0 ("0" means no detection)

Error code table

When an error occurs or the protection mode is set automatically, the wired controller will display the error message.

Code	Protection/Failure Type	Code	Protection/Malfunction
Er01	Phase dislocation	Er23	Low outlet water temperature protection under cooling mode
Er02	Phase loss	Er25	Water level switch failure
Er03	Water flow switch failure	Er27	Outlet water temperature sensor failure
Er04	Anti-freeze protection in winter	Er29	Compressor suction gas temperature sensor failure
Er05	High pressure protection	Er31	Water pressure switch failure
Er06	Low pressure protection	Er35	Compressor high current protection
Er09	Communication failure	Er44	Low ambient temperature protection
Er12	High compressor exhaust gas temp protection	Er45	High outlet water temperature protection under heat mode
Er15	Tank water temp sensor failure		
Er16	Coil temperature sensor failure		
Er18	Exhaust gas temp sensor failure		
Er21	Ambient temp sensor failure		
Er22	Return water temperature sensor failure		

WIRING DIRGRAM

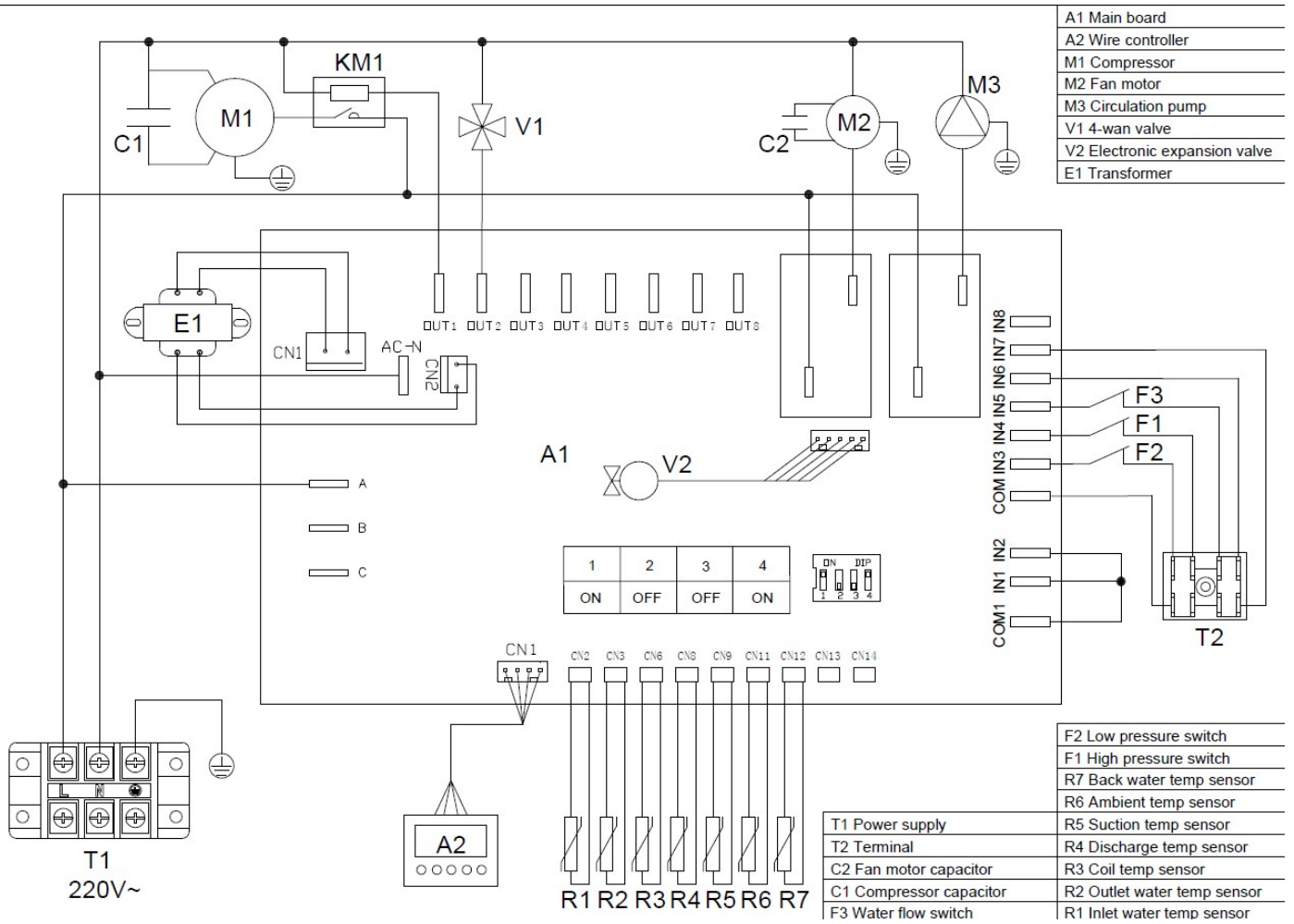

A1	Main board
A2	Wire controller
M1	Compressor
M2	Fan motor
M3	Circulation pump
V1	4-way valve
V2	Electronic expansion valve
E1	Transformer

F2	Low pressure switch
F1	High pressure switch
R7	Back water temp sensor
R6	Ambient temp sensor
R5	Suction temp sensor
R4	Discharge temp sensor
R3	Coil temp sensor
R2	Outlet water temp sensor
R1	Inlet water temp sensor

INSTALLATION OF THE UNIT

Installation guidelines

Precautions for selecting the location

1. Choose a place solid enough to bear the weight and vibration of the unit, where the operation noise will not be amplified.
2. Choose a location where the hot air discharged from the unit, or the operation noise will not cause a nuisance to the neighbours of the user.
3. Avoid places near a bedroom and the like, so that the operation noise will cause no trouble.
4. There must be sufficient space for carrying the unit into and out of the site.
5. There must be sufficient space for air passage and no obstructions around the air inlet and the air outlet.
6. Locate the unit so that the noise and the discharged hot air will not annoy others.
7. The site must be free from the possibility of flammable gas leakage in a nearby place.
8. Install units, power cords and inter-unit cables at least 3m away from television and radio sets. This is to prevent interference to images and sounds.
9. Depending on radio wave conditions, electromagnetic interference can still occur even if installed more than 3m away.
10. In coastal areas or other places with salty atmosphere of sulphate gas, corrosion may shorten the life of the outdoor unit.
11. Since drain flows out of the outdoor unit, do not place anything under the unit which must be kept away from moisture.

Selecting a location in cold climates

 WHEN OPERATING THE OUTDOOR UNIT IN A LOW OUTDOOR AMBIENT TEMPERATURE, BE SURE TO FOLLOW THE INSTRUCTIONS DESCRIBED BELOW.

- To prevent exposure to wind, install the outdoor unit with its suction side facing the wall.
- Never install the outdoor unit at a site where the suction side may be exposed directly to wind.
- To prevent exposure to wind, install a baffle plate on the air discharge side of the outdoor unit.
- In heavy snowfall areas it is very important to select an installation site where the snow will not affect the unit. If lateral snowfall is possible, make sure that the heat exchanger coil is not affected by the snow (if necessary, construct a lateral canopy).

Installation space

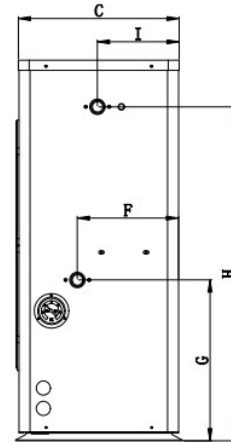
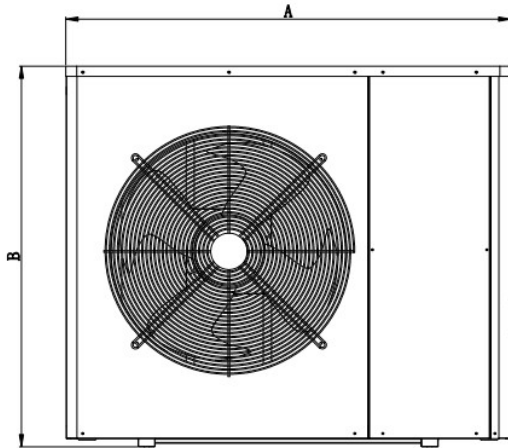
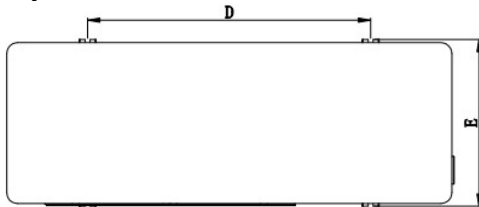

ALL DIMENSION IN mm

	7kW	12kW
A	936	1096
B	794	937
C	377	396
D	728	697
E	410	410
F	236	250
G	111	396
H	421	822
I	320	200

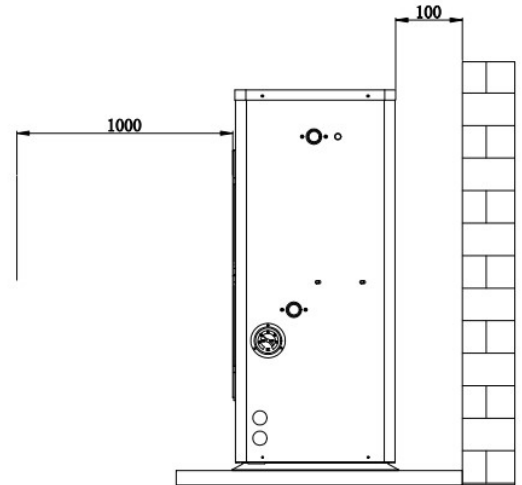
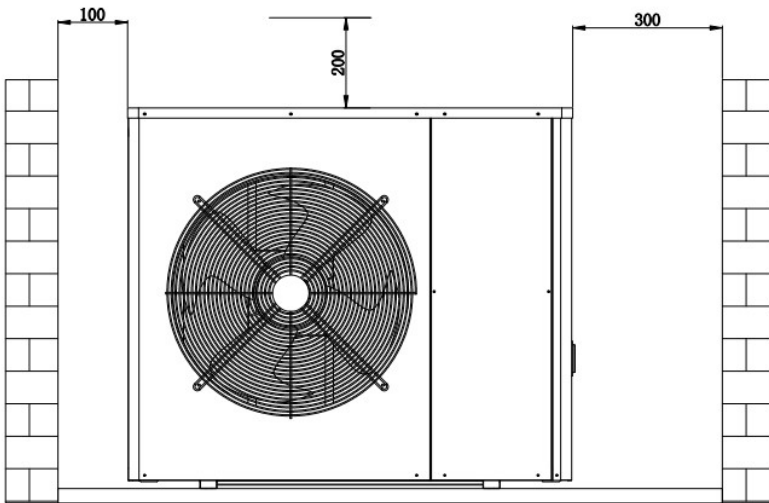

Mounting the unit

When installing the outdoor unit, please refer to “MCS Installation guidelines” to select an appropriate location.

1. Check the strength and level of the installation ground so that the unit will not cause any operating vibration or noise after installation.
2. Prepare 4 sets of M8 foundation bolts, nuts, and washers each.
3. Fix the unit securely by means of the foundation bolts in accordance with the foundation drawing. It is best to screw in the foundation bolts until their length remains 20mm above the foundation surface.

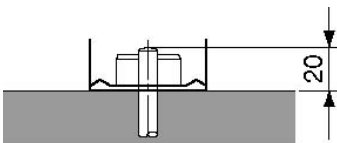

Water pipework

Checking the water circuit

The water circuits must be installed by a licensed technician and must comply with all current regulations.

 THE UNIT IS ONLY TO BE USED IN A CLOSED WATER SYSTEM. APPLICATION IN AN OPEN WATER CIRCUIT CAN LEAD TO EXCESSIVE CORROSION OF THE WATER PIPING.

Before continuing the installation of the unit, check the following points:

- The maximum water pressure is 6 bar.
- Two isolation valves (not supplied) must be fitted to facilitate service and maintenance, please install one at each water inlet/outlet. Orientation of the integrated drain and fill valves is important for servicing.
- Drain taps must be provided at all low points of the system to permit complete drainage of the circuit during maintenance.
- Air vents must be provided at all high points of the system. The vents should be located at points which are easily accessible for servicing. Do the air purge during the installation.
- Take care that the components installed in the field piping can withstand the water pressure.

Connecting the water circuit

Water connections must be made in accordance with the diagram delivered with the unit, respecting the water inlet and outlet connections.

 BE CAREFUL NOT TO DEFORM THE UNIT PIPING BY USING EXCESSIVE FORCE WHEN CONNECTING THE PIPING. DEFORMATION OF THE PIPING CAN CAUSE THE UNIT TO MALFUNCTION.

If air, moisture, or dust gets in the water circuit, problems may occur.

Therefore, always consider the following when connecting the water circuit:

- Use clean pipes only.
- Hold the pipe end downwards when removing burrs.
- Cover the pipe end when inserting it through a wall so that no dust and dirt can enter.
- Use a good thread sealant for the sealing of the connections.
- The sealing must be able to withstand the pressures and temperatures of the system.
- When using non-brass metallic piping, make sure to insulate both materials from each other to prevent galvanic corrosion.
- Because brass is a soft material, use appropriate tooling for connecting the water circuit. Inappropriate tooling will cause damage to the pipes.

 THE UNIT IS ONLY TO BE USED IN A CLOSED WATER SYSTEM. APPLICATION IN AN OPEN WATER CIRCUIT CAN LEAD TO EXCESSIVE CORROSION OF THE WATER PIPING.

 NEVER USE ZN-COATED PARTS IN THE WATER CIRCUIT. EXCESSIVE CORROSION OF THESE PARTS MAY OCCUR AS COPPER PIPING IS USED IN THE INTERNAL WATER CIRCUIT OF THE UNIT.

 WHEN USING A 3-WAY VALVE OR A 2-WAY VALVE IN THE WATER CIRCUIT. THE RECOMMENDED MAXIMUM CHANGE-OVER TIME OF THE VALVE SHOULD BE LESS THAN 60 SECONDS.

Charging water

1. Connect the water supply to a drain and fill valve.



NOTE

- Water quality must be according to EN directive 98/83 EC.

Piping insulation

The complete water circuit, inclusive of all piping, must be insulated to prevent and reduction of the heating capacity.

Field wiring



WARNING

- A main switch or other means for disconnection, having a contact separation in all poles, must be incorporated in the fixed wiring in accordance with relevant local and national legislation.
- Switch 'off' the power supply before making any connections.
- All field wiring and components must be installed by a qualified electrician and must comply with relevant European and national regulations.
- The field wiring must be carried out in accordance with the wiring diagram supplied with the unit and the instructions given below.
- Be sure to use a dedicated power supply. Never use a power supply shared by another appliance.
- Be sure to establish an earth. Do not earth the unit to a utility pipe, surge absorber, or telephone earth. Incomplete earth may cause electrical shock.
- Be sure to install an earth leakage protector. Failure to do so may cause electrical shock.

Auxiliary switching

Terminal 7 on the PCB via a contactor (not supplied) has the ability to switch an auxiliary electric heater.

Use setting L5 from the Parameters list (Page 10) to specify at what ambient air temperature the electric heater operates, adjustable between 0°C - 35°C

Pre-operation checks

Checks before initial start-up



SWITCH OFF THE POWER SUPPLY BEFORE MAKING ANY CONNECTIONS.

After the installation of the unit, check the following before switching on the circuit breaker:

1. Field wiring

Make sure that the field wiring between the local supply panel and appliance has been carried out according to the instructions, according to the wiring diagrams and according to European and national regulations.

2. Fuses or protection devices

Check that the fuses or the locally installed protection devices are of the size and type specified. Make sure that neither a fuse nor a protection device has been by-passed.

3. Earth wiring

Make sure that the earth wires have been connected properly and that the earth terminals are tightened.

4. Internal wiring

Visually check the switch box on loose connections or damaged electrical components.

5. Fixation

Check that the unit is properly fixed, to avoid abnormal noises and vibrations when starting up the unit.

6. Damaged equipment

Check the inside of the unit for damaged components or pipes.

7. Refrigerant leakage

Check the inside of the unit for refrigerant leakage.

8. Power supply voltage

Check the power supply voltage on the local supply panel. The voltage must correspond to the voltage on the identification label of the unit.

9. Water flow switch should be installed for the place where there is no constant sufficient water flow (Field supply)

10. Isolation valves – Must be installed - Failure to do so will invalidate the warranty.

Make sure that the isolation valves are correctly installed and fully open.



OPERATING THE SYSTEM WITH CLOSED VALVES WILL DAMAGE THE PUMP!

MAINTENANCE

To ensure optimal availability of the unit, a number of checks and inspections on the unit and the field wiring must be carried out at regular intervals.



BEFORE CARRYING OUT ANY MAINTENANCE OR REPAIR ACTIVITY, ALWAYS SWITCH 'OFF' THE CIRCUIT BREAKER ON THE SUPPLY PANEL, REMOVE THE FUSES OR OPEN THE PROTECTION DEVICES OF THE UNIT.



MAKE SURE THAT BEFORE STARTING ANY MAINTENANCE OR REPAIR ACTIVITIES THE POWER SUPPLY TO THE OUTDOOR UNIT IS SWITCHED 'OFF'.

INSTALLATION PLAN EXAMPLE FOR COMPLETE SYSTEM

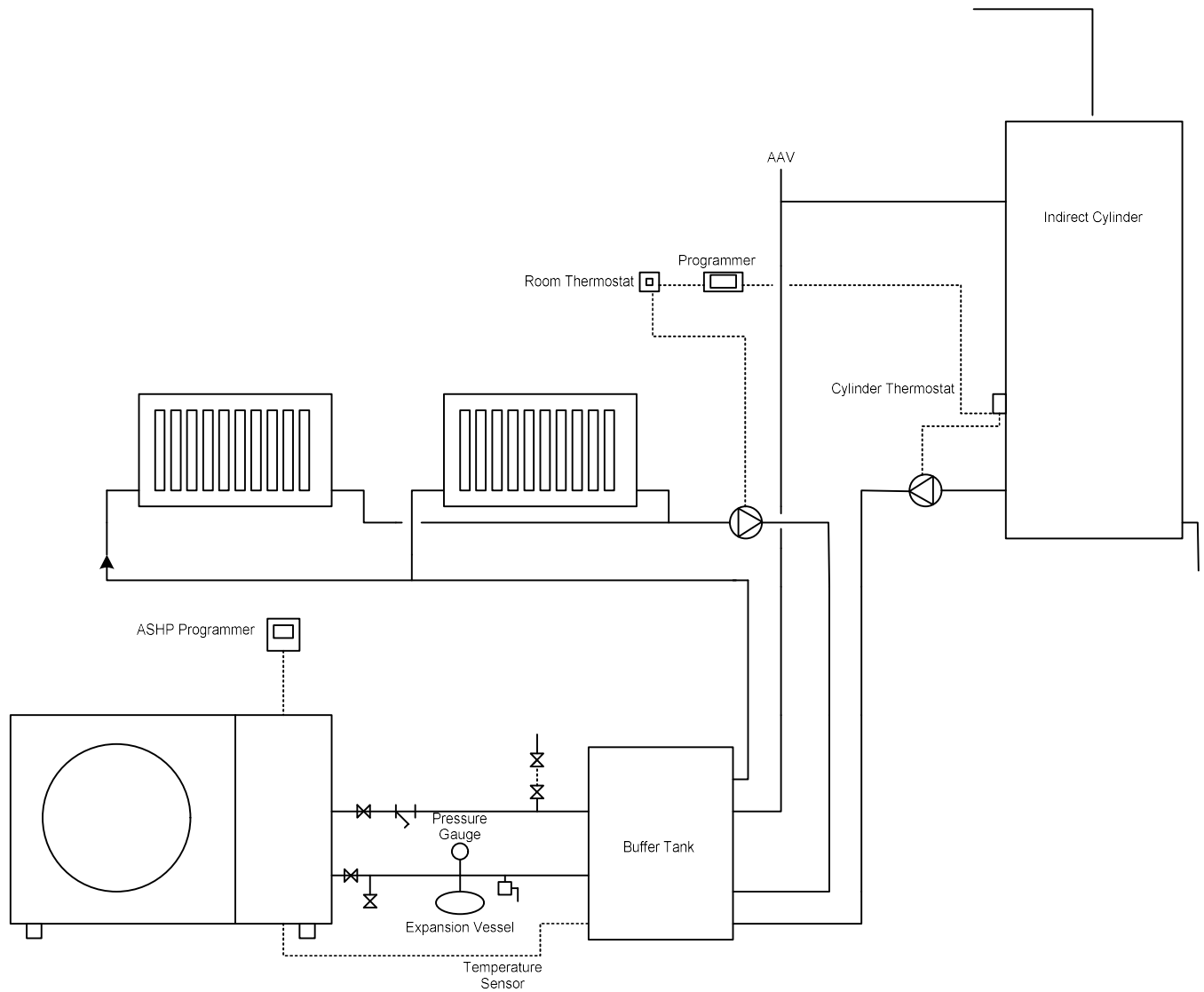

WIRING EXAMPLE

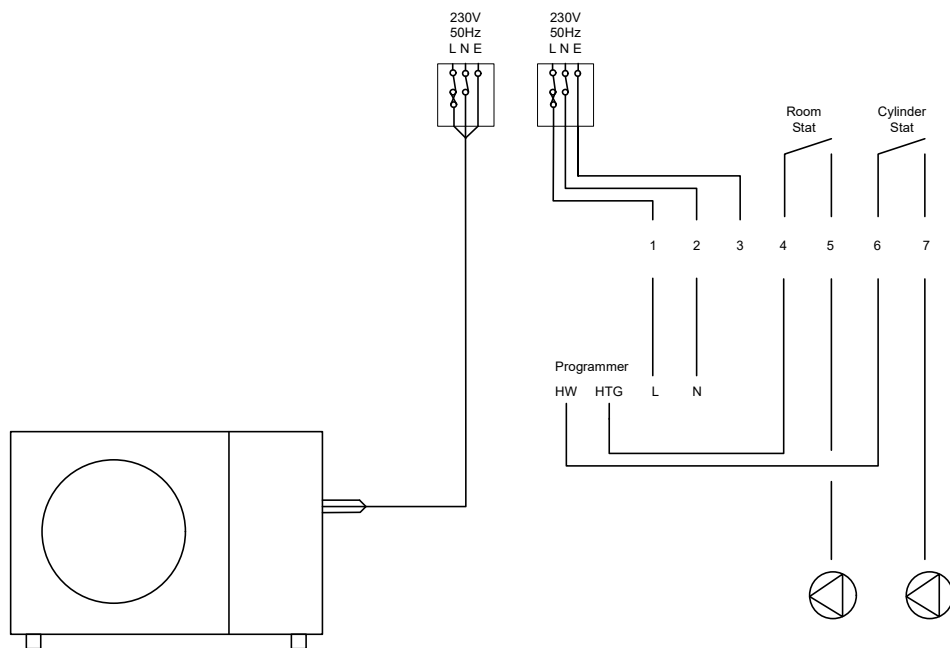

TROUBLESHOOTING

This section provides useful information for diagnosing and correcting certain issues which may occur.

General guidelines

Before starting the troubleshooting procedure, conduct a thorough visual inspection of the unit and look for obvious defects such as loose connections or defective wiring.

Before contacting your local dealer, read this chapter carefully, it will save you time and money.

 WHEN CONDUCTING AN INSPECTION ON THE SWITCH BOX OF THE UNIT, ALWAYS MAKE SURE THAT THE MAIN SWITCH OF THE UNIT IS SWITCHED 'OFF.'

When a safety device was activated, stop the unit, and find out why the safety device was activated before resetting it. Under no circumstances safety devices may be bridged or changed to a value other than the factory setting. If the cause of the problem cannot be found, call your local dealer/installer.

Error codes and Troubleshooting

When an error occurs or the protection mode is set automatically, the wired controller will display the error message.

Protection/ Malfunction	Error code	Reasons	Correction Mode
Phase Dislocation	Er01	Wrong connection of live wire	Reverse position of two of the live wires (3-Phase only).
Phase Loss	Er02	Live wire loose, or without power.	1) Check if wires are loose. 2) Check if any phase is without power (use a multimeter to check voltage).
Water flow switch failure	Er03	1) Inadequate water flow 2) Water flow switch damaged 3) Main PCB damaged	1) Check the pump 2) Replace the water flow switch 3) Replace the PCB
Anti-freeze protection in winter	Er04	This function occurs when ambient temperature is too low.	No action needed
High pressure protection	Er05	1) Inadequate flow rate 2) Uncompressed gas in refrigerant system 3) Overcharge with refrigerant 4) Water temperature setting too high 5) Outdoor fan ventilation is bad 6) Poor connection of pressure switch 7) Pressure switch failure 8) Main PCB damaged	1) Check pump and water control valve 2) Discharge and then recharge the refrigerant 3) Discharge some refrigerant 4) Set lower water temp 5) Check fan ventilation 6) Reconnect the switch 7) Replace the pressure switch 8) Replace the PCB
Low pressure protection	Er06	1) Undercharged refrigerant 2) Capillary or EEV blocked 3) Poor connection of pressure switch 4) Pressure switch failure 5) Main PCB damaged	1) Add some refrigerant 2) Replace the capillary or EEV 3) Reconnect the switch 4) Replace the pressure switch 5) Replace the PCB
Communication failure	Er09	Communication failure between the LCD and PCB	1) Check the wire connection between the LCD and PCB. 2) Replace LCD.
High compressor exhaust gas temperature protection	Er12	1) Refrigerant Undercharged 2) Reasons as Er05	1) Add some refrigerant 2) Similar corrections as Er05
Tank water temperature sensor failure	Er15	1) Sensor open circuit 2) Sensor short circuit 3) Main PCB damaged	1) Check the sensor connection 2) Replace the sensor 3) Replace the main PCB
Coil temperature sensor failure	Er16	1) Sensor open circuit 2) Sensor short circuit 3) Main PCB damaged	1) Check the sensor connection 2) Replace the sensor 3) Replace the main PCB

Compressor exhaust gas temp. sensor failure	Er18	<ol style="list-style-type: none"> 1) Sensor open circuit 2) Sensor short circuit 3) Main PCB damaged 	<ol style="list-style-type: none"> 1) Check the sensor connection 2) Replace the sensor 3) Replace the main PCB
Ambient temporary sensor failure	Er21	<ol style="list-style-type: none"> 1) Sensor open circuit 2) Sensor short circuit 3) Main PCB damaged 	<ol style="list-style-type: none"> 1) Check the sensor connection 2) Replace the sensor 3) Replace the main PCB
Return water temp Sensor failure	Er22	<ol style="list-style-type: none"> 1) Sensor open circuit 2) Sensor short circuit 3) Main PCB damaged 	<ol style="list-style-type: none"> 1) Check the sensor connection 2) Replace the sensor 3) Replace the main PCB
Low outlet water temperature protection under cooling mode	Er23	<ol style="list-style-type: none"> 1) Inadequate water flow rate 2) Low inlet water temp 3) Unreasonable anti-freeze protection temporary setting 4) Main PCB damaged 	<ol style="list-style-type: none"> 1) Check the water filter and water circuit (no block) 2) Adjust the setting temp to normal working range 3) Adjust to right anti-freeze protection temp setting 4) Replace the main PCB
Water level switch failure	Er25	<ol style="list-style-type: none"> 1) Connection terminals loose 2) Water level switch broken 	<ol style="list-style-type: none"> 1) Check connections if good 2) Replace water level switch
Outlet water temperature sensor failure	Er27	<ol style="list-style-type: none"> 1) Sensor open circuit 2) Sensor short circuit 3) Main PCB damaged 	<ol style="list-style-type: none"> 1) Check the sensor connection 2) Replace the sensor 3) Replace the main PCB
Compressor suction gas temperature sensor failure	Er29	<ol style="list-style-type: none"> 1) Sensor open circuit 2) Sensor short circuit 3) Main PCB damaged 	<ol style="list-style-type: none"> 1) Check the sensor connection 2) Replace the sensor 3) Replace the main PCB
Water pressure switch failure	Er31	<ol style="list-style-type: none"> 1) Connection terminals loose 2) Water pressure switch broken 	<ol style="list-style-type: none"> 1) Check connections 2) Replace the water pressure switch
Compressor high current protection	Er35	<ol style="list-style-type: none"> 1) Inadequate water flow rate under heat mode 2) If ambient temperature is exceedingly high under heat mode 3) If fan motor broken under cool mode 	<ol style="list-style-type: none"> 1) Check pump, filter, and water circuit (no block) 2) Check ambient/inlet/out-let water temps 3) Check compressor exhaust and suction gas temps 4) Check fan
Low ambient temp protection	Er44	This function occurs when ambient temperature is too low.	Check if ambient temperature is below -10°C.
High outlet water temp protection under heat mode	Er45	<ol style="list-style-type: none"> 1) Inadequate water flow rate 2) Set outlet water temperature is too high 3) Outlet water temperature sensor or main PCB damaged 	<ol style="list-style-type: none"> 1) Check pump, filter and water circuit (no block) 2) Adjust set outlet water temp to normal working range 3) Replace outlet water temp sensor or main PCB

TR ENGINEERING LTD CUSTOMER AFTER SALES SERVICE INFORMATION

The ASHP comes with a standard 1 Year warranty, this is automatically extended to 2 years free of charge providing the ASHP is registered within 30 days from the date of installation. Either by filling in warranty card if one has been provided or online at: www.trianco.co.uk/product-registration

Please note you will require the full ASHP serial number to be able to register the boiler.

A step-by-step guide to reporting a fault with your appliance.

A qualified field SERVICE ENGINEER is available to attend a breakdown or manufacturing fault occurring whilst the appliance is under warranty.

The appliance must be made available for service during normal working hours, Monday to Friday (no weekend work or bank holidays accepted).

A charge will be made where:

- Our Field Service Engineer finds no fault with the appliance.
- The cause of a breakdown is due to other parts of the plumbing/heating system or with equipment not supplied by TR Engineering Ltd.
- Where the appliance falls outside the warranty period.
- The appliance has not been correctly installed, as recommended (see installation, operating and servicing instructions.)

NOTE: Over 50% of all service calls made are found to have no appliance fault.

What to do in the event of an appliance fault or breakdown:

Step 1: Always contact your installer in the first instance, who must thoroughly check all his work PRIOR to requesting a service visit from TR Engineering LTD.

Step 2: If your appliance has developed an in-warranty fault your installer should contact TR Engineering LTD for assistance from site.

What happens if my Installer/engineer is unavailable?

Step 3: Contact TR Engineering LTD. We will provide you with the name and telephone number of our Service Agent. However, a charge may apply if the fault is not covered by the appliance warranty (payment will be requested on site by our independent Service Agent).

PLEASE NOTE: UNAUTHORISED INVOICES FOR ATTENDANCE AND REPAIR WORK CARRIED OUT ON THIS APPLIANCE BY ANY THIRD PARTY WILL NOT BE ACCEPTED BY TR ENGINEERING LTD

SERVICE CENTRE AND TECHNICAL SUPPORT

Tel: 0114 257 2300 Fax: 0114 257 1419

Hours of Business

Monday to Thursday 8.30am - 5pm

Friday 8.30am - 2.30pm

Technical Specification

Model	Unit	FG 9007	FG 9012
Heating Capacity @ (A7/W35)	kW	7.01	11.93
Heating Input Power @ (A7/W35)	kW	1.65	2.82
COP @ (A7/W35)		4.25	4.23
Heating Capacity @ (A7/W45)	kW	6.96	11.50
Heating Input Power @ (A7/W45)	kW	2.05	3.46
COP @ (A7/W45)		3.40	3.33
Rated Input Current	A	7.5	12.82
Max Input Power	kW	3.52	6.16
Max Input Current	A	16	28
Required Flow Rate	m ³ /h	1.2	2.1
Weight	kg	78	91
Noise	dB(A)	48	52
Min Water Output Temperature	°C	20	20
Max Water Output Temperature	°C	60	60
Power Supply		220V~50Hz	220V~50Hz
Pump		RS 25/7 EA	RS 25/12 EAX
Min Working Pressure	bar	12	12
Max Working Pressure	bar	42	42
Working Ambient Temperature Range	°C	-15~43	-15~43
Required Air Flow	cfm	3250	4500
Refrigerant	g	R32/1300	R32/1900
Electrical Shock Protection		I	I
Moisture Resistance		IPX4	IPX4
Casing Finish		Grey	Grey

Heating Performance

Ambient temperature	-15	-7	2	7	12	20	43
12kW	5.7	7.2	10.2	12.2	14.3	15.7	21.2
7kW	3.5	4.4	5.9	7.4	7.6	9	13.1



TRIANCO

BRINGING HEAT TO LIFE

**TR ENGINEERING LTD
UNIT 7, NEWTON CHAMBERS WAY
THORNCLIFFE INDUSTRIAL ESTATE
CHAPELTOWN
SHEFFIELD
S35 2PH**

Tel: (0114) 2572300

Fax: (0114) 2571419

www.trianco.co.uk

© TR Engineering Limited

Copyright in this brochure and the drawings and illustrations contained in it is vested in TR Engineering Limited and neither the brochure or any part thereof may be reproduced without prior written consent.

TR Engineering Limited's policy is one of continuous research and development. This may necessitate alterations to this specification.